



Instruction Manual

WHEEL CART **POWERCUT-650, 875, 1125, & 1500**

POWERCUT-650 P/N 0558003399
POWERCUT-875 and POWERCUT-1125 P/N 0558003014
POWERCUT-1500 P/N 0558003060

The Wheel Cart is an accessory that permits ease of mobility in the work place for the POWERCUT Console.

Assemble as follows:

1. Assemble the swivel casters to the four groups of four 1/4"—20 studs located on the bottom of the base using 16 supplied lockwashers and nuts.
2. Stand the Wheel Cart up on the casters and position the plasma power unit on to the base. Insert the rubber feet on both ends into the rectangular slots on the ends of the base.
3. Slide the positioning bracket onto the bottom lip of the power supply handle piece and under the base until the slots line up with the press nuts in the base. Secure with 3 supplied locknuts and screws. Do the same to the opposite end.

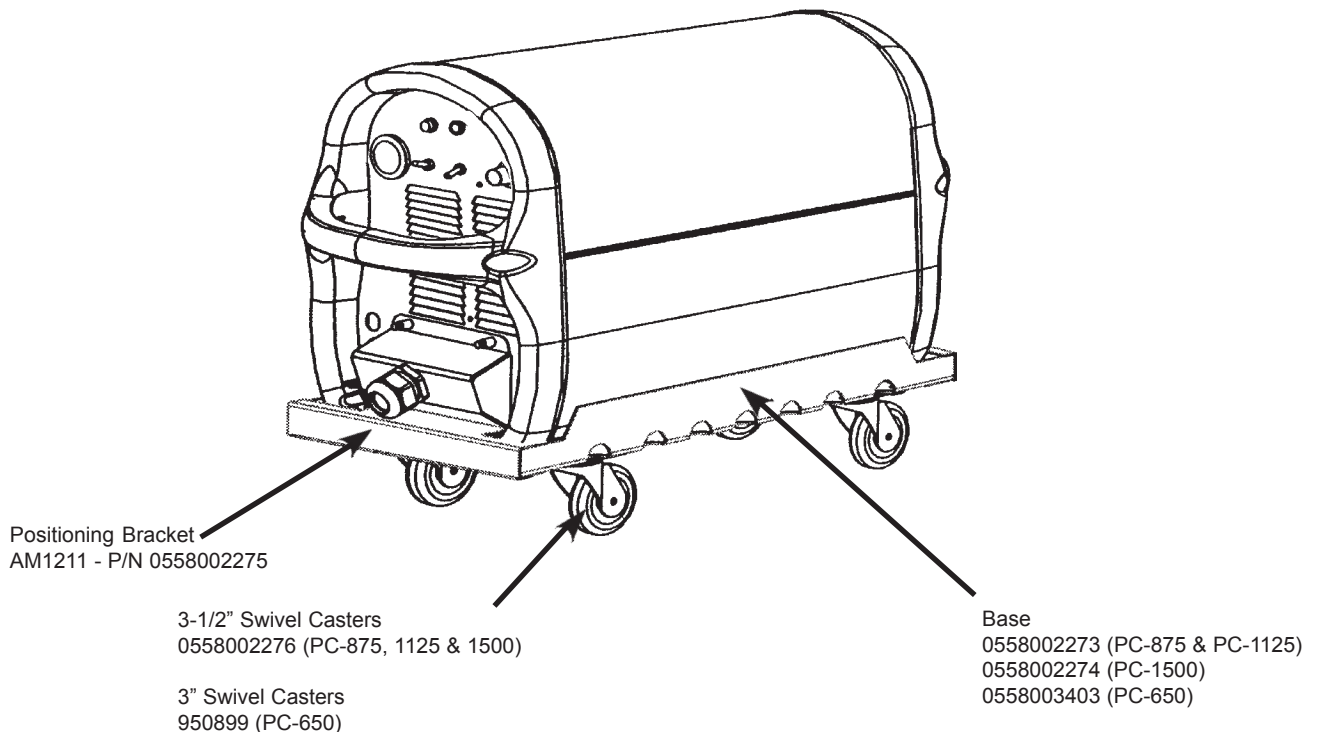

**Be sure this information reaches the operator.
You can get extra copies through your supplier.**



ESAB® ESAB Welding & Cutting Products
PO Box 100545, Florence SC 29501-0545