

# THERMAL DYNAMICS®

AN ESAB® BRAND

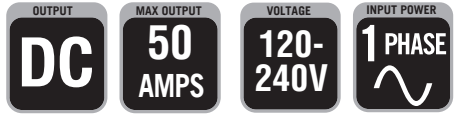

## CUTMASTER® 50+ PLASMA CUTTING SYSTEM

### OPERATING MANUAL



|              |                         |                          |
|--------------|-------------------------|--------------------------|
| Revision: AA | Issue Date: March, 2024 | Manual No.: 0700 402 002 |
|--------------|-------------------------|--------------------------|



**WARNING**  
Cancer and Reproductive Harm  
[www.P65Warnings.ca.gov](http://www.P65Warnings.ca.gov)  
Wash hands after handling.

**esab.com**

# **THERMAL DYNAMICS**

AN **ESAB**® BRAND

## **WE APPRECIATE YOUR BUSINESS!**

Congratulations on your new Thermal Dynamics product. We are proud to have you as our customer and will strive to provide you with the best service and reliability in the industry. This product is backed by our extensive warranty and world-wide service network. To locate your nearest distributor or service agency call 1-800-426-1888, or visit us on the web at **www.esab.com**.

This Operating Manual has been designed to instruct you on the correct use and operation of your Thermal Dynamics product. Your satisfaction with this product and its safe operation is our ultimate concern. Therefore please take the time to read the entire manual, especially the Safety Precautions. They will help you to avoid potential hazards that may exist when working with this product.

## **YOU ARE IN GOOD COMPANY!**

**The Brand of Choice for Contractors and Fabricators Worldwide.**

Thermal Dynamics is a Global Brand of manual and automation Plasma Cutting Products for ESAB.

We distinguish ourselves from our competition through market-leading, dependable products that have stood the test of time. We pride ourselves on technical innovation, competitive prices, excellent delivery, superior customer service and technical support, together with excellence in sales and marketing expertise.

Above all, we are committed to developing technologically advanced products to achieve a safer working environment within the welding industry.



**WARNING**

Read and understand this entire Manual and your employer's safety practices before installing, operating, or servicing the equipment.

While the information contained in this Manual represents the Manufacturer's best judgment, the Manufacturer assumes no liability for its use.

Plasma Cutting Power Supply  
CutMaster® 50+  
SL60™ 1Torch™  
Operating Manual Number 0700 402 002

Published by:  
ESAB Group Incorporated  
2800 Airport Rd.  
Denton, Texas 76207

[www.esab.com](http://www.esab.com)

© Copyright 2024 by  
Thermal Dynamics an ESAB brand.

All rights reserved.

Reproduction of this work, in whole or in part, without written permission of the publisher is prohibited.

The publisher does not assume and hereby disclaims any liability to any party for any loss or damage caused by any error or omission in this Manual, whether such error results from negligence, accident, or any other cause.

Original Publication Date: 05 March, 2024

Revision Date: 05 March, 2024

See website for Warranty Information.

Record the following information for Warranty purposes:

Where Purchased: \_\_\_\_\_

Purchase Date: \_\_\_\_\_

Power Supply Serial #: \_\_\_\_\_

Torch Serial #: \_\_\_\_\_



**Be sure this information reaches the operator.  
You can get extra copies through your supplier.**

## **CAUTION**

**These INSTRUCTIONS are for experienced operators. If you are not fully familiar with the principles of operation and safe practices for arc welding and cutting equipment, we urge you to read our booklet, "Precautions and Safe Practices for Arc Welding, Cutting, and Gouging," Form 52-529. Do NOT permit untrained persons to install, operate, or maintain this equipment. Do NOT attempt to install or operate this equipment until you have read and fully understand these instructions. If you do not fully understand these instructions, contact your supplier for further information. Be sure to read the Safety Precautions before installing or operating this equipment.**

### **USER RESPONSIBILITY**

This equipment will perform in conformity with the description thereof contained in this manual and accompanying labels and/or inserts when installed, operated, maintained and repaired in accordance with the instructions provided. This equipment must be checked periodically. Malfunctioning or poorly maintained equipment should not be used. Parts that are broken, missing, worn, distorted or contaminated should be replaced immediately. Should such repair or replacement become necessary, the manufacturer recommends that a telephone or written request for service advice be made to the Authorized Distributor from whom it was purchased.

This equipment or any of its parts should not be altered without the prior written approval of the manufacturer. The user of this equipment shall have the sole responsibility for any malfunction which results from improper use, faulty maintenance, damage, improper repair or alteration by anyone other than the manufacturer or a service facility designated by the manufacturer.

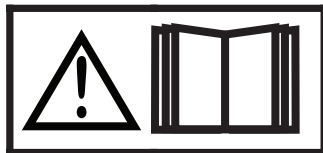

**READ AND UNDERSTAND THE INSTRUCTION MANUAL BEFORE INSTALLING OR  
OPERATING.  
PROTECT YOURSELF AND OTHERS!**



**ASSUREZ-VOUS QUE CETTE INFORMATION EST DISTRIBUÉE À L'OPÉRATEUR.  
VOUS POUVEZ OBTENIR DES COPIES SUPPLÉMENTAIRES CHEZ VOTRE FOUR-  
NISSEUR.**

### **MISE EN GARDE**

Les **INSTRUCTIONS** suivantes sont destinées aux opérateurs qualifiés seulement. Si vous n'avez pas une connaissance approfondie des principes de fonctionnement et des règles de sécurité pour le soudage à l'arc et l'équipement de coupage, nous vous suggérons de lire notre brochure « Precautions and Safe Practices for Arc Welding, Cutting and Gouging, » Brochure 0-5407. Ne permettez **PAS** aux personnes non qualifiées d'installer, d'opérer ou de faire l'entretien de cet équipement. Ne tentez **PAS** d'installer ou d'opérer cet équipement avant de lire et de bien comprendre ces instructions. Si vous ne comprenez pas bien les instructions, communiquez avec votre fournisseur pour plus de renseignements. Assurez-vous de lire les Règles de Sécurité avant d'installer ou d'opérer cet équipement.

### **RESPONSABILITÉS DE L'UTILISATEUR**

Cet équipement opérera conformément à la description contenue dans ce manuel, les étiquettes d'accompagnement et/ou les feuillets d'information si l'équipement est installé, opéré, entretenu et réparé selon les instructions fournies. Vous devez faire une vérification périodique de l'équipement. Ne jamais utiliser un équipement qui ne fonctionne pas bien ou n'est pas bien entretenu. Les pièces qui sont brisées, usées, déformées ou contaminées doivent être remplacées immédiatement. Dans le cas où une réparation ou un remplacement est nécessaire, il est recommandé par le fabricant de faire une demande de conseil de service écrite ou par téléphone chez le Distributeur Autorisé de votre équipement.

Cet équipement ou ses pièces ne doivent pas être modifiés sans permission préalable écrite par le fabricant. L'utilisateur de l'équipement sera le seul responsable de toute défaillance résultant d'une utilisation incorrecte, un entretien fautif, des dommages, une réparation incorrecte ou une modification par une personne autre que le fabricant ou un centre de service désigné par le fabricant.

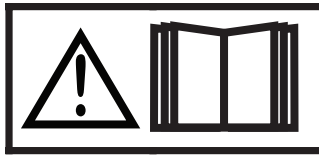

**ASSUREZ-VOUS DE LIRE ET DE COMPRENDRE LE MANUEL D'UTILISATION  
AVANT D'INSTALLER OU D'OPÉRER L'UNITÉ.  
PROTÉGEZ-VOUS ET LES AUTRES!**

This Page Intentionally Blank

# TABLE OF CONTENTS

|  |           |
|--|-----------|
| <b>SECTION 1: GENERAL INFORMATION</b> .....            | <b>9</b>  |
| 1.01 Notes, Cautions and Warnings .....                | 9         |
| <b>SECTION 1 : INFORMATIONS GÉNÉRALES</b> .....        | <b>11</b> |
| 1.01 Remarques, avertissements et mises en garde ..... | 11        |
| <b>SECTION 2 SYSTEM: INTRODUCTION</b> .....            | <b>13</b> |
| 2.01 How To Use This Manual .....                      | 13        |
| 2.02 Equipment Identification .....                    | 13        |
| 2.03 Receipt Of Equipment .....                        | 13        |
| 2.04 Power Supply Specifications ETL.....              | 14        |
| 2.04.01 Additional Power Supply Specifications .....   | 14        |
| 2.05 Input Wiring Specifications ETL.....              | 15        |
| 2.06 Generator Recommendations .....                   | 16        |
| 2.07 Power Supply Features .....                       | 16        |
| <b>SECTION 2 TORCH: INTRODUCTION</b> .....             | <b>19</b> |
| 2T.01 Scope of Manual .....                            | 19        |
| 2T.02 General Description .....                        | 19        |
| 2T.03 Specifications .....                             | 19        |
| <b>SECTION 3 SYSTEM: INSTALLATION</b> .....            | <b>21</b> |
| 3.01 Unpacking .....                                   | 21        |
| 3.02 Lifting Options.....                              | 21        |
| 3.03 Gas Connections .....                             | 22        |
| 3.04 Primary Input Power Connections .....             | 23        |
| 3.05 Work Lead Connections .....                       | 24        |
| <b>SECTION 3 TORCH: INSTALLATION</b> .....             | <b>25</b> |
| 3T.01 Torch Connections.....                           | 25        |
| 3T.02 CNC Connections.....                             | 26        |
| 3T.03 Voltage divider .....                            | 27        |
| 3T.04 Setting Up Automation or Machine Torch .....     | 28        |
| <b>SECTION 4 SYSTEM: OPERATION</b> .....               | <b>29</b> |
| 4.01 Front Panel Controls / Features .....             | 29        |
| 4.02 Preparations for Operation .....                  | 36        |
| <b>SECTION 4 TORCH: OPERATION</b> .....                | <b>39</b> |
| 4T.01 Machine and Automated Torch Operation .....      | 39        |
| 4T.02 Automation Torch Parts Selection .....           | 39        |
| 4T.03 Machine and Hand Torch Parts Selection .....     | 40        |
| 4T.04 Cut Quality.....                                 | 41        |
| 4T.05 General Cutting Information.....                 | 41        |
| 4T.06 Hand Torch Operation .....                       | 42        |
| 4T.07 Gouging.....                                     | 45        |

# TABLE OF CONTENTS

|  |           |
|--|-----------|
| 4T.08 Recommended Cutting Speeds for Machine and Automated Torches With Exposed Tip .....  | 48        |
| 4T.09 Recommended Cutting Speeds for Machine and Automated Torches With Shielded Tip ..... | 50        |
| <b>SECTION 5 SYSTEM: SERVICE .....</b>   | <b>53</b> |
| 5.01 General Maintenance .....   | 53        |
| 5.02 Maintenance Schedule .....  | 53        |
| 5.03 Common Faults.....  | 54        |
| 5.04 Basic Troubleshooting Guide.....  | 55        |
| 5.05 Power Supply Basic Parts Replacement .....  | 57        |
| <b>SECTION 5 TORCH: SERVICE .....</b>  | <b>59</b> |
| 5T.01 General Maintenance .....  | 59        |
| 5T.02 Inspection and Replacement of Consumable Torch Parts .....                           | 60        |
| <b>SECTION 6: PARTS LISTS .....</b>  | <b>61</b> |
| 6.01 Introduction .....  | 61        |
| 6.02 Ordering Information .....  | 61        |
| 6.03 Power Supply Replacement.....   | 61        |
| 6.04 Replacement Parts .....   | 62        |
| 6.05 Front Panel Replacement Part .....  | 63        |
| 6.06 Rear Panel Replacement Part .....   | 64        |
| 6.07 Top Side Replacement Parts .....  | 65        |
| 6.08 Bottom Side Replacement Parts .....   | 66        |
| 6.09 Middle Side Replacement Parts .....   | 67        |
| 6.10 Left Side Replacement Parts .....   | 68        |
| 6.11 Right Side Replacement Parts.....   | 69        |
| 6.12 Cable and Wiring Harness Replacement Parts.....                                       | 70        |
| 6.13 Options and Accessories .....   | 70        |
| 6.14 Replacement Parts for SL60 Hand Torch .....   | 71        |
| 6.15 CM50+ Torch Consumable Parts (SL60) .....   | 72        |
| 6.16 Torch Consumable Parts Manual (SL60) Torch.....                                       | 73        |
| 6.17 Replacement Parts - for SL100 Mechanized Torches with Unshielded Leads .....          | 74        |
| 6.18 Torch Consumable Parts Machine (SL100) Torch .....                                    | 76        |
| <b>APPENDIX 1: DATA TAG INFORMATION .....</b>  | <b>77</b> |
| <b>APPENDIX 2: TORCH PIN - OUT DIAGRAMS .....</b>  | <b>78</b> |
| <b>APPENDIX 3: TORCH CONNECTION DIAGRAMS .....</b>   | <b>79</b> |
| <b>APPENDIX 4: RAW ARC VOLTAGE.....</b>  | <b>80</b> |
| <b>APPENDIX 5: SYSTEM SCHEMATIC.....</b>   | <b>81</b> |

**SECTION 1: GENERAL INFORMATION****1.01 Notes, Cautions and Warnings**

Throughout this manual, notes, cautions, and warnings are used to highlight important information. These highlights are categorized as follows:

**NOTE!**

An operation, procedure, or background information which requires additional emphasis or is helpful in efficient operation of the system.

**CAUTION**





A procedure which, if not properly followed, may cause damage to the equipment.

**WARNING**

A procedure which, if not properly followed, may cause injury to the operator or others in the operating area.

**WARNING**

Gives information regarding possible electrical shock injury.

|   |     |     |     |  <b>WARNING</b>  |  <b>AVERTISSEMENT</b>  |
|---|-----|-----|-----|---|---|
| 1   | 1.1 | 1.2 | 1.3 | <b>1. Cutting sparks can cause explosion or fire.</b><br>1.1 Do not cut near flammables.<br>1.2 Have a fire extinguisher nearby and ready to use.<br>1.3 Do not use a drum or other closed container as a cutting table.  | <b>1. Les étincelles de coupage peuvent provoquer une explosion ou un incendie.</b><br>1.1 Ne pas couper près des matières inflammables.<br>1.2 Un extincteur doit être à proximité et prêt à être utilisé.<br>1.3 Ne pas utiliser un fût ou un autre contenant fermé comme table de coupage.   |
| 2   | 2.1 | 2.2 | 2.3 | <b>2. Plasma arc can injure and burn; point the nozzle away from yourself. Arc starts instantly when triggered.</b><br>2.1 Turn off power before disassembling torch.<br>2.2 Do not grip the workpiece near the cutting path.<br>2.3 Wear complete body protection.       | <b>2. L'arc plasma peut blesser et brûler; éloigner la buse de soi. Il s'allume instantanément quand on l'amorce</b><br>2.1 Couper l'alimentation avant de démonter la torche.<br>2.2 Ne pas saisir la pièce à couper de la trajectoire de coupage.<br>2.3 Se protéger entièrement le corps.  |
| 3   | 3.1 | 3.2 | 3.3 | <b>3. Hazardous voltage. Risk of electric shock or burn.</b><br>3.1 Wear insulating gloves. Replace gloves when wet or damaged.<br>3.2 Protect from shock by insulating yourself from work and ground.<br>3.3 Disconnect power before servicing. Do not touch live parts. | <b>3. Tension dangereuse. Risque de choc électrique ou de brûlure.</b><br>3.1 Porter des gants isolants. Remplacer les gants quand ils sont humides ou endommagés.<br>3.2 Se protéger contre les chocs en s'isolant de la pièce et de la terre.<br>3.3 Couper l'alimentation avant l'entretien. Ne pas toucher les pièces sous tension. |
| 4   | 4.1 | 4.2 | 4.3 | <b>4. Plasma fumes can be hazardous.</b><br>4.1 Do not inhale fumes.<br>4.2 Use forced ventilation or local exhaust to remove the fumes.<br>4.3 Do not operate in closed spaces. Remove fumes with ventilation.   | <b>4. Les fumées plasma peuvent être dangereuses.</b><br>4.1 Ne pas inhaler les fumées.<br>4.2 Utiliser une ventilation forcée ou un extracteur local pour dissiper les fumées.<br>4.3 Ne pas couper dans des espaces clos. Chasser les fumées par ventilation.   |
| 5   | 5.1 |     |     | <b>5. Arc rays can burn eyes and injure skin.</b><br>5.1 Wear correct and appropriate protective equipment to protect head, eyes, ears, hands, and body. Button shirt collar. Protect ears from noise. Use welding helmet with the correct shade of filter.               | <b>5. Les rayons d'arc peuvent brûler les yeux et blesser la peau.</b><br>5.1 Porter un bon équipement de protection pour se protéger la tête, les yeux, les oreilles, les mains et le corps. Boutonner le col de la chemise. Protéger les oreilles contre le bruit. Utiliser un masque de soudeur avec un filtre de nuance appropriée. |
| 6   |     |     |     | <b>6. Become trained.</b><br>Only qualified personnel should operate this equipment. Use torches specified in the manual. Keep non-qualified personnel and children away.   | <b>6. Suivre une formation.</b><br>Seul le personnel qualifié a le droit de faire fonctionner cet équipement. Utiliser exclusivement les torches indiquées dans le manuel. Le personnel non qualifié et les enfants doivent se tenir à l'écart.   |
| 7   |     |     |     | <b>7. Do not remove, destroy, or cover this label.</b><br>Replace if it is missing, damaged, or worn.   | <b>7. Ne pas enlever, détruire ni couvrir cette étiquette.</b><br>La remplacer si elle est absente, endommagée ou usée.   |

Art # A-13294

**SECTION 1 : INFORMATIONS GÉNÉRALES****1.01 Remarques, avertissements et mises en garde**

Le présent manuel est ponctué de remarques, d'avertissements et de mises en garde qui attirent l'attention sur des informations importantes. Ces repères sont classés comme suit :

**REMARQUE :**

Fonction, procédé ou renseignement de base qui nécessite une plus grande attention ou contribue au bon fonctionnement du système.

**ATTENTION**

Procédé qui, s'il n'est pas suivi correctement, peut endommager l'équipement.

**AVERTISSEMENT**

Procédé qui, s'il n'est pas suivi correctement, peut causer des lésions à l'utilisateur ou aux personnes dans la zone d'exploitation.

**AVERTISSEMENT**

Fournit des renseignements relatifs à d'éventuelles blessures se devant à une décharge électrique.

|   |     |     |     | <b>WARNING</b>   | <b>AVERTISSEMENT</b>   |
|---|-----|-----|-----|--|--|
| 1 | 1.1 | 1.2 | 1.3 | <p><b>1. Cutting sparks can cause explosion or fire.</b></p> <p>1.1 Do not cut near flammables.</p> <p>1.2 Have a fire extinguisher nearby and ready to use.</p> <p>1.3 Do not use a drum or other closed container as a cutting table.</p>  | <p><b>1. Les étincelles de coupage peuvent provoquer une explosion ou un incendie.</b></p> <p>1.1 Ne pas couper près des matières inflammables.</p> <p>1.2 Un extincteur doit être à proximité et prêt à être utilisé.</p> <p>1.3 Ne pas utiliser un fût ou un autre contenant fermé comme table de coupage.</p>   |
| 2 | 2.1 | 2.2 | 2.3 | <p><b>2. Plasma arc can injure and burn; point the nozzle away from yourself. Arc starts instantly when triggered.</b></p> <p>2.1 Turn off power before disassembling torch.</p> <p>2.2 Do not grip the workpiece near the cutting path.</p> <p>2.3 Wear complete body protection.</p>       | <p><b>2. L'arc plasma peut blesser et brûler; éloigner la buse de soi. Il s'allume instantanément quand on l'amorce</b></p> <p>2.1 Couper l'alimentation avant de démonter la torche.</p> <p>2.2 Ne pas saisir la pièce à couper de la trajectoire de coupage.</p> <p>2.3 Se protéger entièrement le corps.</p>  |
| 3 | 3.1 | 3.2 | 3.3 | <p><b>3. Hazardous voltage. Risk of electric shock or burn.</b></p> <p>3.1 Wear insulating gloves. Replace gloves when wet or damaged.</p> <p>3.2 Protect from shock by insulating yourself from work and ground.</p> <p>3.3 Disconnect power before servicing. Do not touch live parts.</p> | <p><b>3. Tension dangereuse. Risque de choc électrique ou de brûlure.</b></p> <p>3.1 Porter des gants isolants. Remplacer les gants quand ils sont humides ou endommagés.</p> <p>3.2 Se protéger contre les chocs en s'isolant de la pièce et de la terre.</p> <p>3.3 Couper l'alimentation avant l'entretien. Ne pas toucher les pièces sous tension.</p> |
| 4 | 4.1 | 4.2 | 4.3 | <p><b>4. Plasma fumes can be hazardous.</b></p> <p>4.1 Do not inhale fumes.</p> <p>4.2 Use forced ventilation or local exhaust to remove the fumes.</p> <p>4.3 Do not operate in closed spaces. Remove fumes with ventilation.</p>   | <p><b>4. Les fumées plasma peuvent être dangereuses.</b></p> <p>4.1 Ne pas inhaler les fumées.</p> <p>4.2 Utiliser une ventilation forcée ou un extracteur local pour dissiper les fumées.</p> <p>4.3 Ne pas couper dans des espaces clos. Chasser les fumées par ventilation.</p>   |
| 5 | 5.1 |     |     | <p><b>5. Arc rays can burn eyes and injure skin.</b></p> <p>5.1 Wear correct and appropriate protective equipment to protect head, eyes, ears, hands, and body. Button shirt collar. Protect ears from noise. Use welding helmet with the correct shade of filter.</p>                       | <p><b>5. Les rayons d'arc peuvent brûler les yeux et blesser la peau.</b></p> <p>5.1 Porter un bon équipement de protection pour se protéger la tête, les yeux, les oreilles, les mains et le corps. Boutonner le col de la chemise. Protéger les oreilles contre le bruit. Utiliser un masque de soudeur avec un filtre de nuance appropriée.</p>         |
| 6 | 6   |     |     | <p><b>6. Become trained.</b></p> <p>Only qualified personnel should operate this equipment. Use torches specified in the manual. Keep non-qualified personnel and children away.</p>   | <p><b>6. Suivre une formation.</b></p> <p>Seul le personnel qualifié a le droit de faire fonctionner cet équipement. Utiliser exclusivement les torches indiquées dans le manuel. Le personnel non qualifié et les enfants doivent se tenir à l'écart.</p>   |
| 7 | 7   |     |     | <p><b>7. Do not remove, destroy, or cover this label.</b></p> <p>Replace if it is missing, damaged, or worn.</p>   | <p><b>7. Ne pas enlever, détruire ni couvrir cette étiquette.</b></p> <p>La remplacer si elle est absente, endommagée ou usée.</p>   |

Art # A-13294



## 2.01 How To Use This Manual

This Owner's Manual applies to just product(s) listed on page i.

To ensure safe operation, read the entire manual, including the chapter on safety instructions and warnings.

Electronic copies of this manual can be downloaded at no charge in Acrobat PDF format on the ESAB web site listed below then clicking on "SUPPORT" / "Manuals", and you can also use your phone or tablet to scan the QR code on page i, enter your search criteria above to locate the documents.

<http://www.esab.com>

## 2.02 Equipment Identification

The unit's identification number (specification or part number), model, and serial number appear on a data tag attached to the rear panel. Equipment which does not have a data tag such as torch and cable assemblies are identified only by the specification or part number printed on loosely attached card or the shipping container. Record these numbers on the bottom of page i for future reference.

## 2.03 Receipt Of Equipment

When you receive the equipment, check it against the invoice to make sure it is complete and inspect the equipment for possible damage due to shipping. If there is any damage, notify the carrier immediately to file a claim. Furnish complete information concerning damage claims or shipping errors to the location in your area listed on the back cover of this manual.

Include all equipment identification numbers as described above, along with a full description of the parts in error.

### Included items:

- CutMaster 50+ Power Supply
- SL60™ Torch and Leads
- Work Lead with Work Clamp
- Spare Parts Kit ( 2 Electrodes, 1 Start Cartridge, 2 Cutting Tips, 1 Gouging Tip, 1 Shield Cup, 1 Shield Cup Body, 1 Drag Shield Cap, 1 Standoff Cutting Guide, 1 Deflector Shield Cap and 1 Gouging Shield Cap)
- 50 Amp to 20 Amp Adapter
- 20 Amp to 15 Amp Adapter
- Quick Start Guide
- Air fitting 1/4" NPT Milton type D

Move the equipment to the installation site before un-boxing the unit. Use care to avoid damaging the equipment when opening the box.

**2.04 Power Supply Specifications ETL**

| <b>CM 50+ 120-240 VAC 1 Phase Power Supply Specifications</b> |   |
|---|---|
| Input Power   | 120 - 240 VAC, Single Phase, 50/60 Hz   |
| 1 Phase Input Power Cable ETL                                 | Power Supply includes 3 M single phase 10AWG 3/C input cable with NEMA 6-50P Plug |
| Output Current  | 15 - 50A, Continuously Adjustable   |
| Power Supply Gas Filtering Ability                            | Particulates to 5 Microns   |
| Inlet Pressure  | 90-125 psi (6.2-8.6 bar / 620-862 kPa)  |

**2.04.01 Additional Power Supply Specifications**

| <b>CM 50+ Power Supply Duty Cycle *</b> |   |        |      |      |
|---|---|--------|------|------|
| Ambient Air Temperature                 | Duty Cycle Ratings @ 40° C (104° F)<br>Operating Range 0°C - 50°C |        |      |      |
|   |   | Rating |      |      |
| 120 VAC Units                           | Duty Cycle*   | 40%    | 60%  | 100% |
|   | Current   | 25A**  | 21A  | 16A  |
|   | DC Voltage  | 120V   | 120V | 120V |
| 208-240 VAC Units                       | Duty Cycle*   | 50%    | 60%  | 100% |
|   | Current   | 50A    | 40A  | 30A  |
|   | DC Voltage  | 150V   | 150V | 150V |

\* NOTE: The duty cycle will be reduced if the primary input power (AC) is low or the output voltage (DC) is higher than shown in this chart.

\*\* NOTE: 25A output setting is for a 20A circuit ONLY!  
DO NOT exceed a 15A output setting on a 15A circuit!

2.05 Input Wiring Specifications ETL

1 Phase Input Cable Wiring Requirements

| 1 Phase Cutmaster 50+ Power Supply Input Cable Wiring Requirements |               |       |             |       |                  |                  |                          |
|--|---------------|-------|-------------|-------|------------------|------------------|--------------------------|
|  | Input voltage | Freq  | Power Input |       |                  | Suggested Sizes  |                          |
|  | Volts (AC)    | Hz    | kVA         | I max | I <sub>eff</sub> | Fuse (ampereage) | Flexible Cord (Min. AWG) |
| 1 Phase  | 120V          | 50/60 | 2.3         | 19.2A | 13.6A            | 15A              | 10 AWG                   |
|  | 120V          | 50/60 | 3.7         | 30.3A | 19.2A            | 20A              | 10 AWG                   |
|  | 208V          | 50/60 | 8.6         | 41.3A | 29.2A            | 70A              | 10 AWG                   |
|  | 220V          | 50/60 | 8.6         | 39A   | 27.6A            | 70A              | 10 AWG                   |
|  | 230V          | 50/60 | 8.6         | 37.4A | 26.4A            | 70A              | 10 AWG                   |
|  | 240V          | 50/60 | 8.6         | 36A   | 25.5A            | 70A              | 10 AWG                   |

Line Voltages with Suggested Circuit Protection and Wire Sizes  
Based on National Electric Code and Canadian Electric Code

**NOTE!** Refer to Local and National Codes or local authority having jurisdiction for proper wiring requirements. Cable size is de-rated based on the Duty Cycle of the equipment.

**MAX OUTPUT POWER / INPUT POWER** 0700402347

|   |   |  |
|---|---|--|
| <p><b>MAX OUTPUT</b><br/><b>15A</b></p> <p><b>15 Amp</b><br/><b>120 VAC</b></p> | <p><b>MAX OUTPUT</b><br/><b>25A</b></p> <p><b>20 Amp</b><br/><b>120 VAC</b></p> | <p><b>MAX OUTPUT</b><br/><b>50A</b></p> <p><b>50 Amp</b><br/><b>208-240V</b></p> |
|---|---|--|

| CM 50+ Cut Capacity |                      |                          |
|---------------------|----------------------|--------------------------|
| <b>Pierce</b>       | <b>Standard Edge</b> | <b>Maximum Severance</b> |
| Up to 5/8" (16mm)   | Up to 1" (25mm)      | Up to 1 1/4" (32mm)      |

**2.06 Generator Recommendations**

When using generators to power the CM 50+ Plasma Cutting System, the following ratings are a minimum and are to be used along with the ratings previously listed.

| <b>CM 50+ Generator Specifications</b> |                       |                           |
|--|-----------------------|---------------------------|
| <b>Generator Output Rating</b>         | <b>Output Current</b> | <b>Arc Characteristic</b> |
| 4 kW / 120 VAC                         | 15A on 15A circuit    | Full                      |
| 6 kW / 120 VAC                         | 25A on 20A circuit    | Full                      |
| 15 kW / 240 VAC                        | 50A                   | Full                      |

NOTE: If Generator is equipped with an idle mode it will need to be in "Run" mode to operate at 50 amps.

**NOTE!**

Due to circuitry, age and condition two generators with the same ratings may produce different results. Adjust the amperage accordingly.

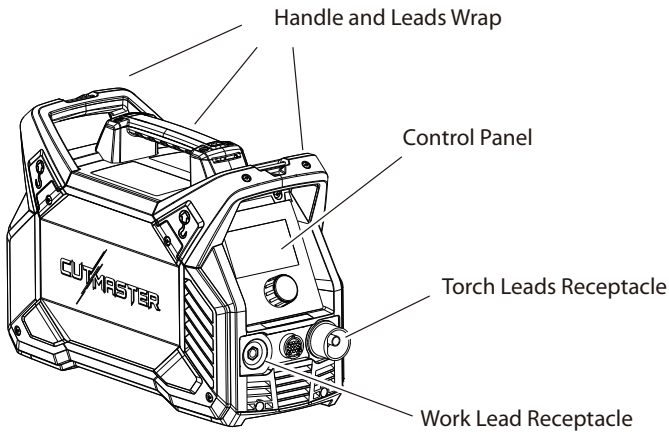
**2.07 Power Supply Features**

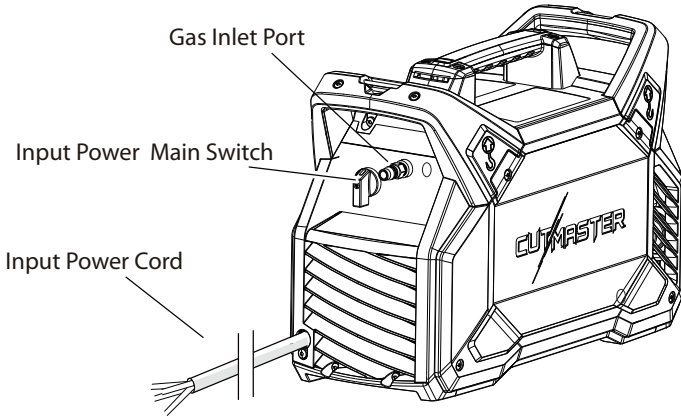

**Weights and Dimensions**

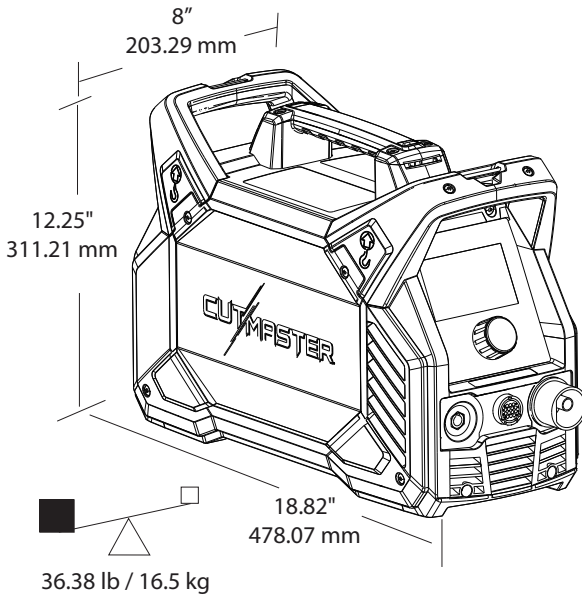

*Power Supply Dimensions & Weight*

**Clearances for Operation and Ventilation**

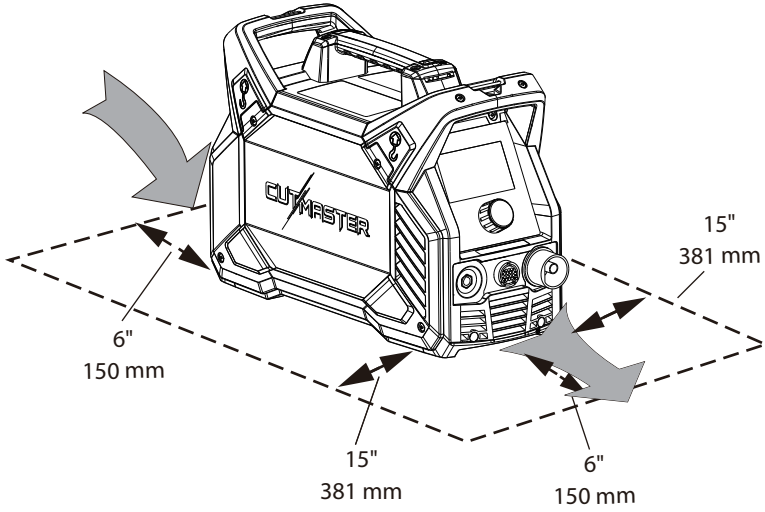

*Ventilation Clearance Requirements*

**SECTION 2 TORCH: INTRODUCTION**

**2T.01 Scope of Manual**

This manual contains descriptions, operating instructions and maintenance procedures for the 1Torch Model SL60™ Plasma Cutting Torch. Service of this equipment is restricted to properly trained personnel; unqualified personnel are strictly cautioned against attempting repairs or adjustments not covered in this manual, at the risk of voiding the Warranty.

Read this manual thoroughly. A complete understanding of the characteristics and capabilities of this equipment will assure the dependable operation for which it was designed.

**2T.02 General Description**

|   |  |
|---|--|
|  | <p><b>CAUTION</b></p> <p>Torch Leads are flexible but internal wires can be broken. Do not exceed a 2" radius bend and avoid repeated tight bends when possible.</p> |
|---|--|

Refer to the Appendix Pages for additional specifications as related to the Power Supply used.

**2T.03 Specifications**

**A. Torch Configurations**

- 1. Hand/Manual Torch, Models

The hand torch head is at 75° to the torch handle. The hand torches include a torch handle and torch trigger assembly.

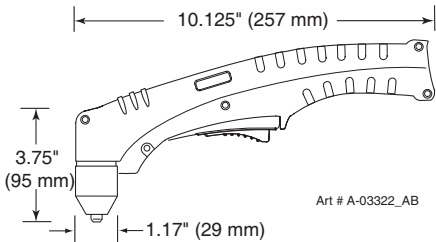

**B. Hand Torches are available as follows:**

- 20 ft / 6.1 m                      7-5200

**C. Torch Parts**

Starter Cartridge, Electrode, Tip, Shield Cup

**D. Parts - In - Place (PIP)**

Torch Head has built - in switch

27.5±1.5 VDC circuit rating

**E. Type Cooling**

Combination of ambient air and gas stream through torch.

**F. Torch Ratings**

| Manual Torch Ratings              |                       |
|-----------------------------------|-----------------------|
| <b>Ambient Temperature</b>        | 104° F<br>40° C       |
| <b>Duty Cycle</b>                 | 100% @ 60A @ 400 scfh |
| <b>Maximum Current</b>            | 60A                   |
| <b>Voltage (V<sub>peak</sub>)</b> | 500 VDC               |
| <b>Arc Striking Voltage</b>       | 500 VDC               |

**G. Gas Requirements**

| Manual Torch Gas Specifications            |   |
|--|---|
| <b>Gas (Plasma and Secondary)</b>          | Compressed Air                                  |
| <b>Operating Pressure</b><br>Refer to NOTE | 90 - 120 psi<br>6.2 - 8.3 bar                   |
| <b>Maximum Input Pressure</b>              | 125 psi / 8.6 bar                               |
| <b>Gas Flow (Cutting and Gouging)</b>      | 5 - 8.3 SCFM<br>300 - 500 scfh<br>142 - 235 lpm |

|   |   |
|---|---|
|  | <p><b>WARNING</b></p> <p>This Torch is not to be used with oxygen (O<sub>2</sub>). The SL60QD torch should not be used on an HF system.</p> |
|---|---|

|   |  |
|---|--|
|  | <p><b>NOTE!</b></p> <p>Operating pressure varies with torch model, operating amperage, and torch leads length. Refer to gas pressure settings charts for each model.</p> |
|---|--|

**H. Direct Contact Hazard**

For standoff tip the recommended standoff is 3/16 inches / 4.7 mm.

This Page Intentionally Blank



**SECTION 3 SYSTEM: INSTALLATION****3.01 Unpacking**

1. Use the packing lists to identify and account for each item.
2. Inspect each item for possible shipping damage. If damage is evident, contact your distributor and / or shipping company before proceeding with the installation.
3. Record Power Supply and Torch model and serial numbers, purchase date and vendor name, in the information block at the front of this manual.

**3.02 Lifting Options**

The Power Supply includes handles for **hand lifting only**. Be sure unit is lifted and transported safely and securely.

**WARNING**

Do not touch live electrical parts.

Disconnect input power cord before moving unit.

FALLING EQUIPMENT can cause serious personal injury and can damage equipment. HANDLES are not for mechanical lifting.

- Only persons of adequate physical strength should lift the unit.
- Lift unit by the handles, using two hands. Do not use straps for lifting.
- Use optional cart or similar device of adequate capacity to move unit.

**Connecting Gas Supply to Unit**

The connection is the same for compressed air or high pressure cylinders.

1. Connect the air line to the quick connect inlet port. The following illustration shows typical gas line with quick connect fittings as an example.

**NOTE!**

For a secure seal, apply thread sealant to the fitting threads, according to manufacturer's instructions. Do not use Teflon tape as a thread sealer, as small particles of the tape may break off and block the small air passages in the torch.

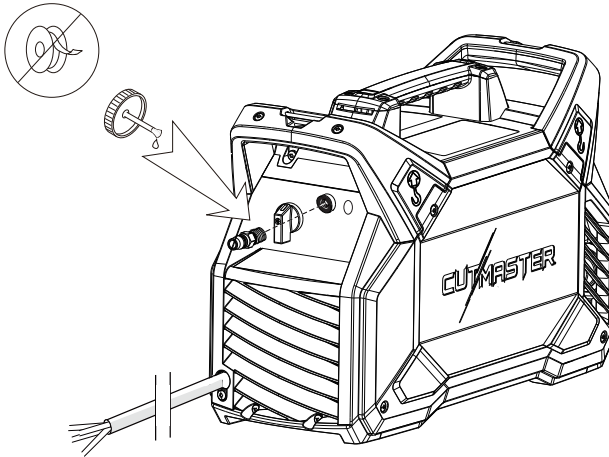

*Applying Thread Sealant*

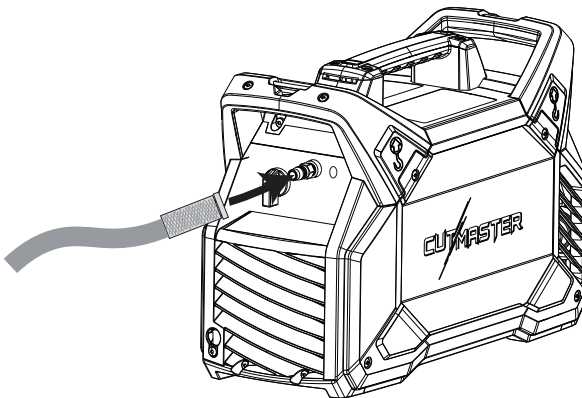

*Air Connection to Inlet Port*

- IF using high pressure cylinders, or your supply pressure exceeds 125 psi / 8.62 bar / 862 kPa, you **MUST** use regulator to lower pressure to between 90 - 125 psi / 6.2 - 8.6 bar / 620 - 862 kPa before introducing air to the system.



**WARNING**

Failure to regulate inbound air pressure below 125 psi / 8.62 bar / 862 kPa may cause damage to the unit.

**3.04 Primary Input Power Connections**



**CAUTION**

Check your power source for correct voltage before connecting the unit to input power. The primary power source, fuse, and any extension cords used must conform to local electrical code and the recommended circuit protection and wiring requirements as specified in Section 2.

**Power Cords Included With the Power Supply**

Power cords come attached on all systems. For North America it will come with a 50 amp plug for use on 208-240 VAC/50A circuit.

Also included for **ETL systems ONLY**, are two adapters. One is a cable with a 120 VAC/20A NEMA 5-20P plug which attaches to the power supply input cord via a NEMA 6-50R plug. The other is a NEMA 5-20R to NEMA 5-15P adapter plug that attaches to the other adapter.



**CAUTION**

When using the 120 VAC/20A adapter cord (ETL systems ONLY), do not exceed a current output setting of 25A on the power supply or the input power circuit breaker may trip.



**WARNING**

When using the 15A adapter in conjunction with the 20A adapter (ETL systems ONLY), extreme caution should be used to not exceed a current output setting of 15A on the power supply. Failure to do so may result in the input power circuit breaker tripping or branch circuit overheating.

| Input Voltage                  | Rated Output<br>ARC Amperage<br>\ ARC Voltage | Amperage (RMS) input<br>at rated output, 60 Hz,<br>single-phase | kVA |
|--------------------------------|---|---|-----|
| 120 VAC, 15A Circuit (ETL)     | 15A, 120VDC                                   | 19.2A   | 2.3 |
| 120 VAC, 20A Circuit (ETL)     | 25A, 120 VDC                                  | 31A   | 3.7 |
| 208-240 VAC, 50A Circuit (ETL) | 50A, 150 VDC                                  | 36-41A  | 8.6 |

**ETL ONLY**

0700402347

|   |   |  |
|---|---|--|
| <p><b>MAX OUTPUT</b><br/><b>15A</b></p> <p><b>15 Amp</b><br/><b>120 VAC</b></p> | <p><b>MAX OUTPUT</b><br/><b>25A</b></p> <p><b>20 Amp</b><br/><b>120 VAC</b></p> | <p><b>MAX OUTPUT</b><br/><b>50A</b></p> <p><b>50 Amp</b><br/><b>208-240V</b></p> |
|---|---|--|

**3.05 Work Lead Connections**

Connect the Work Lead to the power supply and the work piece.

1. Attach the Dinse type connection of the work lead to the power supply front panel as shown below.
2. Push in and turn clockwise to the right until tight.
3. Connect the work clamp to the workpiece or cutting table. The area must be free from oil, paint and rust. Connect only to the main part of the work piece; do not connect to the part to be cut off.

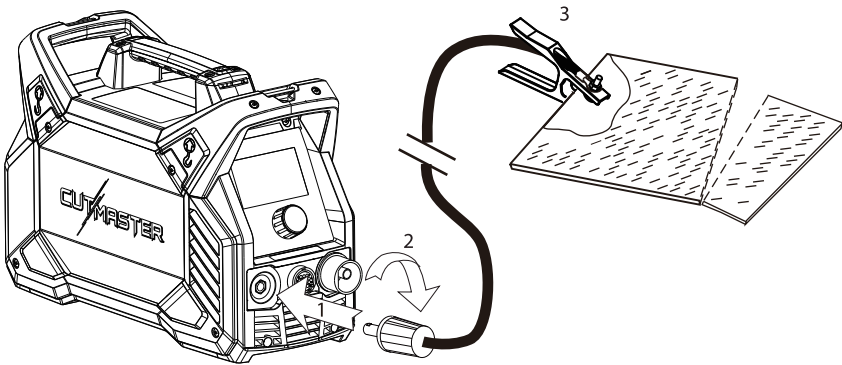

See section 3T for torch installation.

**SECTION 3 TORCH: INSTALLATION****3T.01 Torch Connections**

Connect the torch to the Power Supply. Connect only the ESAB model SL60 torch to this power supply. Maximum torch leads length is 50 feet/15m, including extensions.

**WARNING**

Disconnect primary power at the source before connecting the torch.

1. Align the ATC male connector (on the torch lead) with the female receptacle. Push the male connector into the female receptacle. The connectors should push together with a small amount of pressure.
2. Secure the connection by turning the locking nut clockwise until it clicks. **DO NOT** use the locking nut to pull the connection together. Do not use tools to secure the connection.

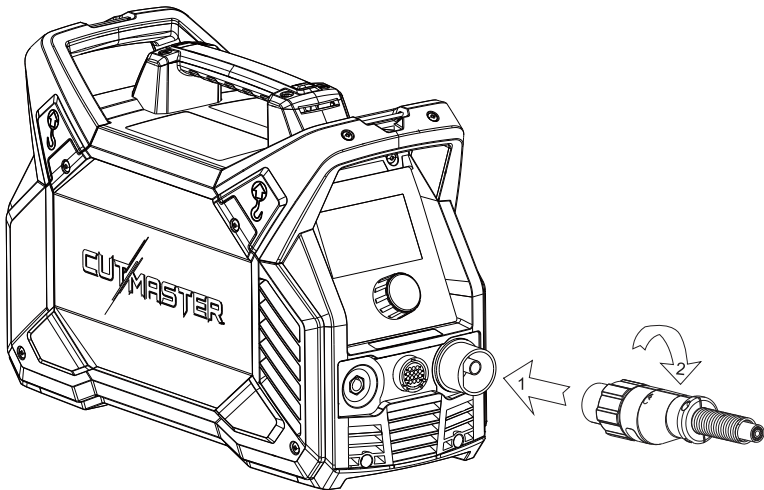

*Connecting the Torch to the Power Supply*

1. Locate the interface connection port on the front of the power supply.

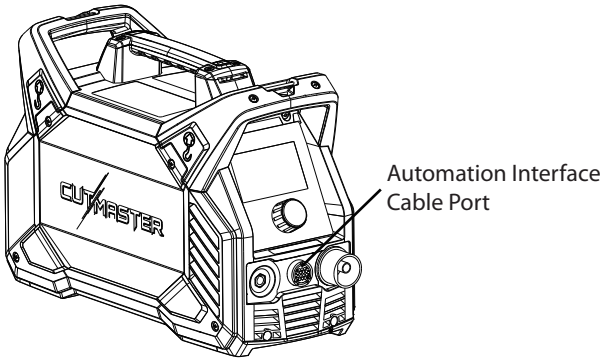

2. Note the pin-out of the connector and that the customer supplied connector matches.

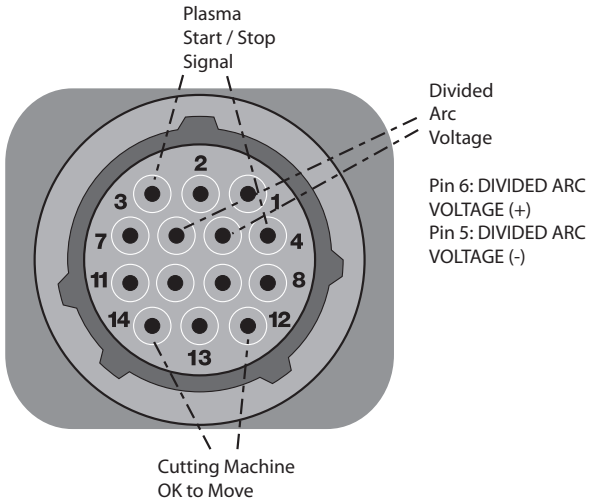

3T.03 Voltage divider

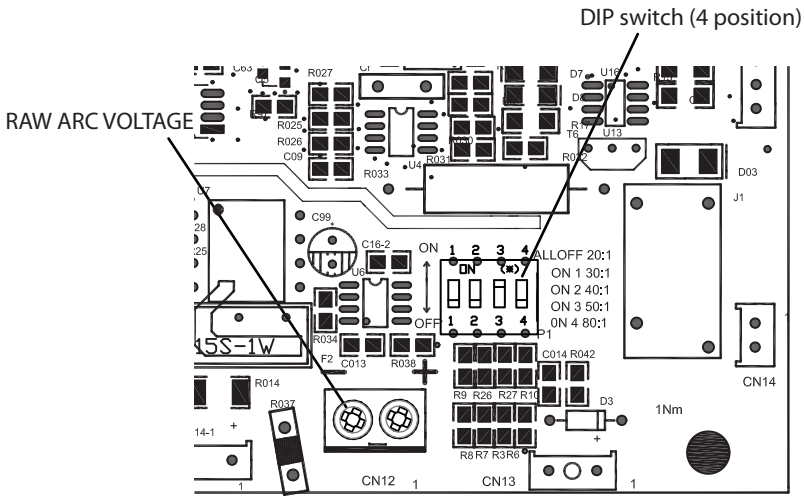

**Voltage divider**

The 4 position DIP switch, P1, makes available the following divide ratios:

- All OFF: = 20:1 for ESAB;
- DIV1-1 ON: = 30:1;
- DIV1-2 ON: = 40:1 for Inova;
- DIV1-3 ON: = 50:1 for IHT, SC3000&3100, Hypertherm® (Default);
- DIV1-4 ON: = 80:1 for TD iHC

Divided arc voltage signal is isolated.

**Raw Arc Voltage**

Refer to Appendix 4.

**i NOTE!** Only one position should be on at a time.

**Rating:**

The OK to Move are relay contacts rated for maximum of 30V AC or DC at 1 amp maximum.

Start SW input requires a switch or relay contact rated for at least 24VDC at 5mA.

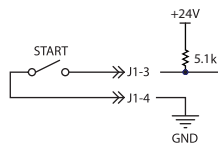

**NOTE!**

An adapter is required to be installed in the power supply if converting a hand torch system to operate a machine or automation torch.

**WARNING**

Disconnect primary power at the source before disassembling the torch or torch leads.

The Automation and Machine torch include a positioning tube with rack and pinch block assembly.

1. Mount the torch assembly on the cutting table.
2. To obtain a clean vertical cut, use a square to align the torch perpendicular to the surface of the workpiece.

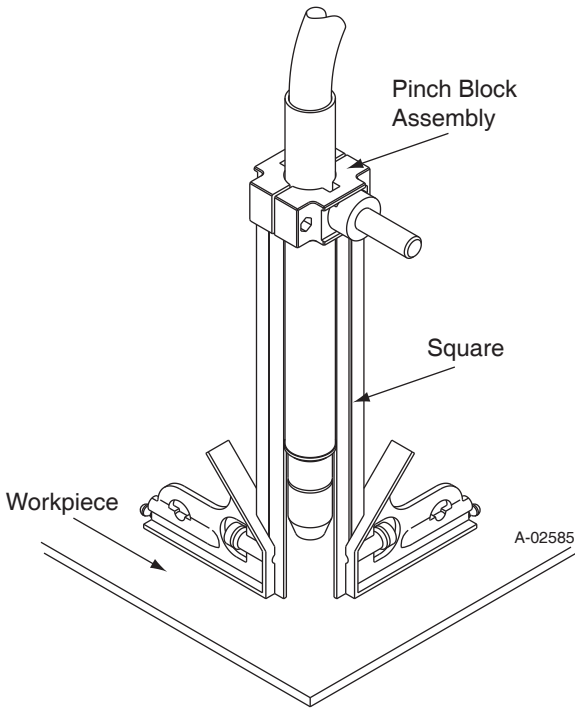

*Automated and Machine Torch Set - Up*

3. The proper torch parts (shield cup, tip, start cartridge, and electrode) must be installed for the type of operation. Refer to Section 4T.08, Torch Parts Selection for details.



## 4.01 Front Panel Controls / Features

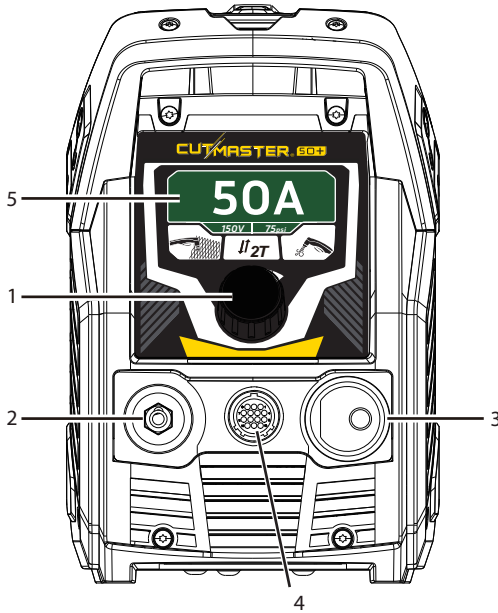

## 1. Control Knob



To select the Menu or change values.



To adjust the cutting current:

- Turn clockwise to increase the cutting current.
- Turn counterclockwise to reduce the cutting current.

To select an option in the menu displayed, press the control knob to enter the menu screen. After entering the menu screen, the options are highlighted in sequence at each turn.

-  To select the icon on the menu screen and exit menu screen.
-  To change the selection.

## 2. Work lead Dinse type receptacle

Align Dinse type connector on work lead with receptacle, press in and turn clockwise to the right until tight.

## 3. Torch Quick Disconnect Receptacle

Torch Leads are connected here by aligning the connectors, pressing in and turning locking ring clockwise-to-the-right to secure. Connection should only be snug with no tools used.

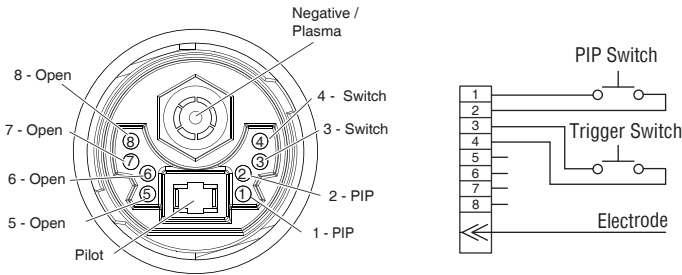

## 4. Automation Interface Cable Port

Refer to sections 3T.02 and 3T.03.

## 5. LCD screen

The front panel has an LCD screen to display the cutting mode, cutting current, cutting voltage, air pressure, and error information.

### WELCOME SCREEN

The welcome screen is displayed for 3 seconds while the equipment turns ON.



After the welcome screen, the model name is displayed for 3 seconds.



## MAIN SCREEN

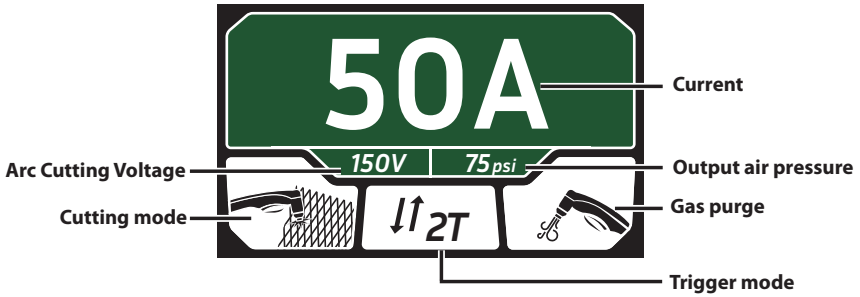

## MENU SCREEN

To enter the menu screen, press the control knob. In the menu screen, the user may adjust the cutting mode, trigger mode, and gas purge. To exit the menu screen, rotate the control knob to main screen.

## 1) CUTTING MODE SELECTION SCREEN

To enter the cutting mode selection, press the control knob, and the cutting mode is highlighted.

To change the selection, press the knob, and the cutting mode changes between plate cutting mode and grid cutting mode.

To confirm the selection, rotate the control knob to exit cutting mode selection menu.

Plate cutting mode: Used for general cutting operations;

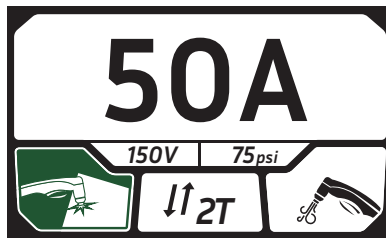

Grid Cutting Mode: Allows for faster restarting of the Pilot Arc for uninterrupted cutting. With the system in the grid cutting mode, when the torch leaves the workpiece the pilot arc restarts instantly, and the cutting arc restarts instantly when the pilot arc contacts the workpiece. (Use the 'grid cutting' mode when cutting expanded metal or gratings, or trimming operations when an uninterrupted restart is desired).

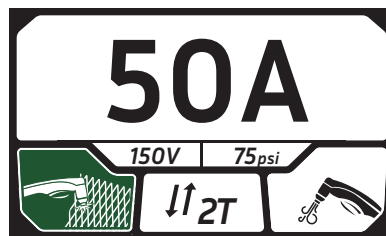

**2) TRIGGER MODE SELECTION SCREEN**

To enter the cutting mode selection, press the control knob to enter menu screen. Turn the knob clockwise to enter trigger mode screen. The trigger mode is highlighted. To change the selection, press the knob, and the trigger mode changes between 2T (normal) mode and 4T (lock mode) mode. Rotate the control knob to exit the trigger mode selection screen to confirm the selection.

**Note that 4T trigger mode is only available at plate cutting mode. When grid cutting mode is selected, 4T trigger mode can't be selected.**

2T (normal): Once the cutting arc is established, it should continue to cut until the trigger is released.

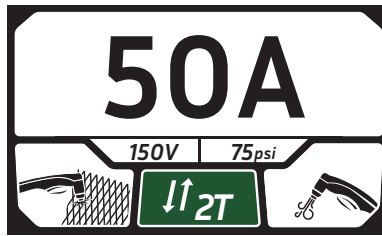

4T (lock mode): Used for longer hand held or mechanical cuts. (Does not apply to automation). Once a cutting arc is established, the torch switch can be released. The cutting arc will remain ON until the torch is lifted away from the workpiece or the torch leaves the edge of the workpiece or the torch switch is triggered again.

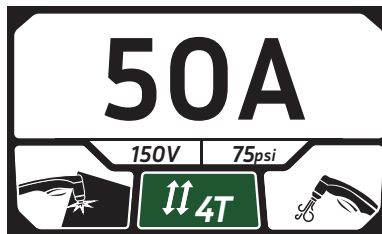

## 3) GAS PURGE SCREEN

To enter gas purge, press the control knob to enter menu screen. Turn the knob clockwise to enter gas purge screen.

Press the control knob to activate the gas purge.

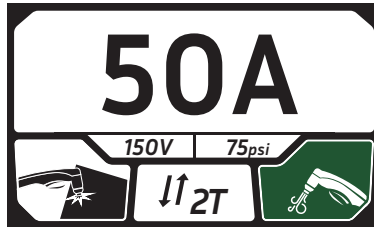

Press the control knob again to stop the gas purge, and rotate the control knob to exit the gas purge screen.

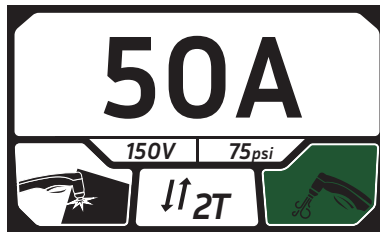

## 4) GAS PRESSURE UNIT SELECTION SCREEN

In idle state, set 22A current and select 4T trigger mode. Only when the 4T trigger mode is highlighted, press the control knob for about 5s to enter the gas pressure unit selection screen. Rotate the control knob, select the gas pressure unit (psi/kPa/bar), and press the control knob to confirm the selection.

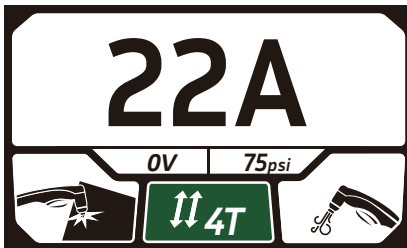

**Error screen**

There are several error warnings screens to indicate errors. When an error happens, the communication screen will display and cut off the output until the error is cleared.

**1) OVERHEATING COMMUNICATION SCREEN**

The cutting equipment is protected by a temperature sensor. The overheating communication screen is displayed if the machine is overheated, which normally occurs if the equipment duty cycle is exceeded.

If the overheating communication screen displays the machine output shall be deactivated. Let the equipment ON to allow the internal components to cool down. When the equipment is cool enough, the overheating communication screen disappears automatically.

Please note that since the protected point of 120VAC input is lower, the overheating communication screen will display for a while when changing the input from 240VAC to 120VAC, usually after working in 240VAC for a period of time.

**2) AIR PRESSURE COMMUNICATION SCREEN**

The air pressure communication screen is displayed if the output air pressure is out of range (below 43.5 psi / 3 bar / 300kPa, or above 110 psi / 7.6 bar / 760kPa). Note: the machine will not display the communication if the torch is not connected to ATC.

**3) TORCH INSTALLATION OR COVER ASSEMBLY COMMUNICATION SCREEN**

The torch installation or incorrect cover assembly communication screen is displayed when the torch or torch consumable is not installed correctly. Note: the machine will not display the communication if the torch is not connected to ATC.

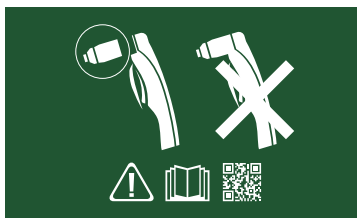

**4) ELECTRODE OR TIP INSTALLATION COMMUNICATION SCREEN**

The electrode or cutting nozzle installation communication screen is displayed when the electrode or cutting nozzle is not installed correctly or wear seriously. Check or replace the worn cutting nozzle and electrode. Note: the machine will not display the communication if the torch is not connected to ATC.

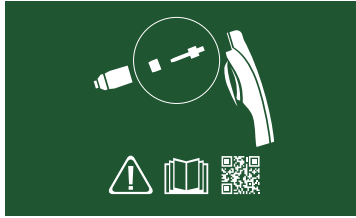
**5) UNDER VOLTAGE COMMUNICATION SCREEN**

The under voltage communication screen is displayed when the input voltage is under 85 VAC, check that the input voltage is not less than 100 VAC.

**(6) START ERROR COMMUNICATION SCREEN**

Start signal is active when ON/ OFF SWITCH is turned to ON position.

Start can be active for the following:

- Hand torch switch held closed
- CNC start signal held on



At the start of each operating session:

**WARNING**

Disconnect primary power at the source before assembling or disassembling power supply, torch parts, or torch and leads assemblies.

**Torch Parts Selection**

Check the torch for proper assembly and appropriate torch parts. The torch parts must correspond with the type of operation, and with the amperage output of this Power Supply (50 amps maximum at 240 VAC or 25 amps at 120 VAC). Refer to Section 4T.01 for torch parts order.

**Torch Connection**

Check that the torch is properly connected. Only Thermal Dynamics models SL60 Manual Torches may be connected to this Power Supply. See Section 3T.01 of this manual.

**Check Primary Input Power Source**

1. Check the power source for proper input voltage. Make sure the input power source meets the power requirements for the unit per Section 2, Specifications.
2. Connect the input power cable (or close the main disconnect switch) to supply power to the system.

**Air Source**

Ensure source meets requirements (refer to Section 2). Check connections and turn air supply ON.

**Connect Work Cable**

Clamp the work cable to the workpiece or cutting table. The work cable clamp area must be free from oil, paint and rust. Connect only to the main part of the workpiece; do not connect to the part to be cut off.

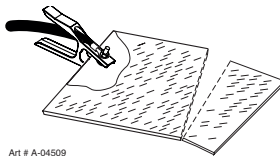

Art # A-04509

**Power ON**

Place the Power Supply main switch to the "I" (right) position. LCD turns ON. The Main Board performs several tests to determine the system is ready to operate.

If there are no issues detected the output current setting will be displayed from 15 to 50 or 70 amps.

The cooling fan will turn ON for one second as the unit is turned ON and will auto to run when the unit is working normally.



## Set Operating Pressure

Gas pressure can be set in the power supply, from 50 - 90 psi / 3.4 - 6.2 bar / 340- 620 kPa.

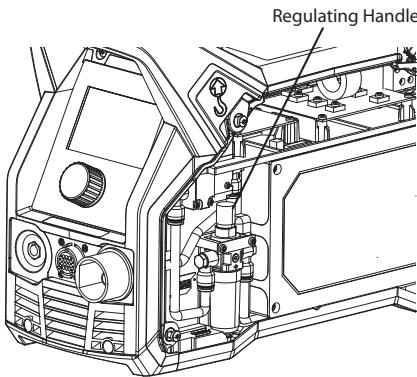

1. Remove the right panel, inbuilt air regulator assembly is located in front of the power supply;
2. Turn the control knob to the GAS PURGE position, press the knob, and gas will flow.
3. Pull the regulating handle to adjust the gas pressure;  
 Make clockwise adjustment to increase the gas pressure;  
 Make counterclockwise adjustment to decrease the gas pressure;
4. After finishing the adjustment, push the regulating handle.
5. Reinstall the right panel.

## Cutting Operation

Once the cutting arc is established, it should continue to cut until the trigger is released, the torch is moved too far from the work piece or the duty cycle has been exceeded causing the system to go into an over temperature mode. In the first two instances release the torch trigger, ensure that the torch tip is close to the work piece, activate the trigger and reestablish the cutting arc. In the event of an over temperature fault, release the trigger, allow the unit to run so it will cool down. When the fault clears you can begin cutting again.

## Typical Cutting Speeds

Cutting speeds vary according to torch output amperage, gas pressure, the type of material being cut, and operator skill.

Output current setting or cutting speeds may be reduced to allow slower cutting when following a line, or using a template or cutting guide while still producing cuts of excellent quality. As thickness of metal being cut increases cutting speed will need to slow. The opposite is true. As thickness of metal being cut decreases, allowable cutting speed can increase.

## Postflow

Release the trigger to stop the cutting arc. Gas continues to flow for approximately 30 seconds. During post - flow, if the user quickly presses and releases the trigger, the gas will shut off. If the user continues to hold the trigger and not release it, the pilot arc starts. The main arc will transfer to the workpiece if the torch tip is within transfer distance.

## Shutdown

Turn the main switch to O, to the left as you face the unit from the rear. After a short delay all Power Supply indicators and fan shut OFF. Unplug the input power cord or disconnect input power. Power is removed from the system.



### NOTE!

To maximize the longevity of the internal electronics, allow the power supply to continue running (without cutting) for a few minutes before turning OFF. This will allow them to cool faster.

This Page Intentionally Blank

## SECTION 4 TORCH: OPERATION

### 4T.01 Machine and Automated Torch Operation

#### Cutting With Machine or Automated Torch

These torches are activated by remote control pendant or by a remote interface device such as CNC.

1. To start a cut at the plate edge, position the center of the torch along the edge of the plate.

#### Travel Speed

Proper travel speed is indicated by the trail of the arc which is seen below the plate. The arc can be one of the following:

#### 1. Straight Arc

A straight arc is perpendicular to the workpiece surface. This arc is generally recommended for the best cut using air plasma on stainless or aluminum.

#### 2. Leading Arc

The leading arc is directed in the same direction as torch travel. A five degree leading arc is generally recommended for air plasma on mild steel.

#### 3. Trailing Arc

The trailing arc is directed in the opposite direction as torch travel.

For optimum smooth surface quality, the travel speed should be adjusted so that only the leading edge of the arc column produces the cut. If the travel speed is too slow, a rough cut will be produced as the arc moves from side to side in search of metal for transfer.

Travel speed also affects the bevel angle of a cut. When cutting in a circle or around a corner, slowing down the travel speed will result in a squarer cut. The power source output should be reduced also. Refer to the appropriate Control Module Operating Manual for any Corner Slowdown adjustments that may be required.

#### Piercing With Machine or Automated Torch

To pierce, the arc should be started with the torch positioned as high as possible above the plate while allowing the arc to transfer and pierce. This standoff helps avoid having molten metal blow back onto the front end of the torch.

When operating with a cutting machine, a pierce or dwell time is required. Torch travel should not be enabled until the arc penetrates the bottom of the plate. As motion begins, torch standoff should be reduced to the recommended 1/8 - 1/4 inch (3-6 mm) distance for optimum speed and cut quality. Clean spatter and scale from the shield cup and the tip as soon as possible. Spraying or dipping the shield cup in anti - spatter compound will minimize the amount of scale which adheres to it.

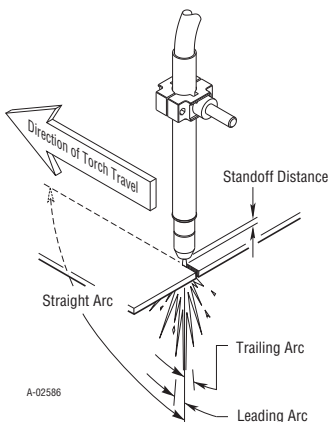

Automation and Machine Torch Operation

### 4T.02 Automation Torch Parts Selection

Check the torch for proper consumable parts. The parts supplied in the torch may not be correct for the operator's chosen amperage level or operation type. Use Deflector in mechanized applications that do not require "Ohmic-Touch" initial height sensing. Use Shield Cap and Ohmic Clip in mechanized applications that require "Ohmic-Touch" initial height sensing. The torch parts must correspond with the type of operation.

## Torch parts:

Shield Cup, Cutting Tip, Electrode and Start Cartridge



### NOTE!

Refer to Sections "4T.02 Automation Torch Parts Selection" and following for additional information on torch parts.

Change the torch parts for a different operation as follows:



### WARNING

Disconnect primary power at the source before assembling or disassembling torch parts, or torch and leads assemblies.



### NOTE!

The shield cup holds the tip and start cartridge in place. Position the torch with the shield cup facing upward to keep these parts from falling out when the cup is removed.

1. If attached, remove the ohmic clip then unscrew and remove the shield cup assembly from the torch head. Wipe it clean or replace if damaged
2. Remove the electrode by pulling it straight out of the Torch Head.

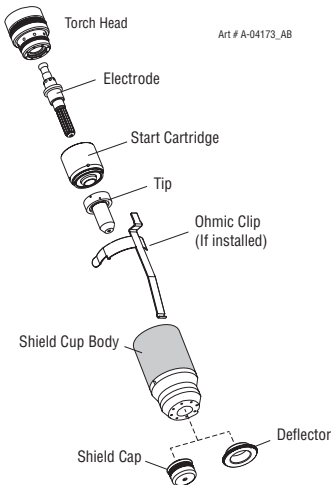

Automation Torch Parts

3. Install the replacement electrode by pushing it straight into the torch head until it clicks.

4. Install the start cartridge and desired tip for the operation into the torch head.
5. Hand tighten the shield cup assembly until it is seated on the torch head. If resistance is felt when installing the cup, check the threads before proceeding
6. If used, attach the ohmic clip to the shield cup.

## 4T.03 Machine and Hand Torch Parts Selection

The type of operation determines the torch parts to be used.

### Type of operation:

Drag cutting, standoff cutting or gouging

### Torch parts:

Shield Cup, Cutting Tip, Electrode and Start Cartridge



### NOTE!

Refer to Section "4T.03 Machine and Hand Torch Parts Selection" and following for additional information on torch parts.

Change the torch parts for a different operation as follows:



### WARNING

Disconnect primary power at the source before assembling or disassembling torch parts, or torch and leads assemblies.



### NOTE!

The shield cup holds the tip and start cartridge in place. Position the torch with the shield cup facing upward to keep these parts from falling out when the cup is removed.

1. Unscrew and remove the shield cup assembly from the torch head.
2. Remove the electrode by pulling it straight out of the Torch Head.

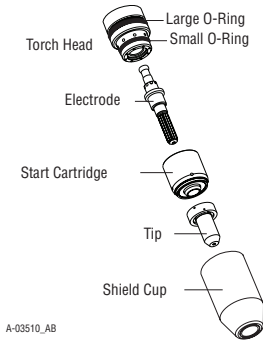

Torch Parts (Drag Shield Cap & Shield Cup Body Shown)

3. Install the replacement electrode by pushing it straight into the torch head until it clicks.
4. Install the start cartridge and desired tip for the operation into the torch head.
5. Hand tighten the shield cup assembly until it is seated on the torch head. If resistance is felt when installing the cup, check the threads before proceeding.

**4T.04 Cut Quality**



**NOTE!**

Cut quality depends heavily on setup and parameters such as torch standoff, alignment with the workpiece, cutting speed, gas pressures, and operator ability.

Cut quality requirements differ depending on application. For instance, nitride build - up and bevel angle may be major factors when the surface will be welded after cutting. Dross - free cutting is important when finish cut quality is desired to avoid a secondary cleaning operation. The following cut quality characteristics are illustrated in the following figure:

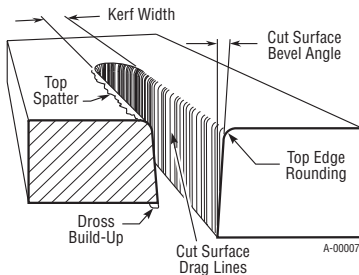

Cut Quality Characteristics

**Cut Surface**

The desired or specified condition (smooth or rough) of the face of the cut.

**Nitride Build - Up**

Nitride deposits can be left on the surface of the cut when nitrogen is present in the plasma gas stream. These buildups may create difficulties if the material is to be welded after the cutting process.

**Bevel Angle**

The angle between the surface of the cut edge and a plane perpendicular to the surface of the plate. A perfectly perpendicular cut would result in a 0° bevel angle.

**Top - Edge Rounding**

Rounding on the top edge of a cut due to wearing from the initial contact of the plasma arc on the workpiece.

**Bottom Dross Buildup**

Molten material which is not blown out of the cut area and resolidifies on the plate. Excessive dross may require secondary cleanup operations after cutting.

**Kerf Width**

The width of the cut (or the width of material removed during the cut).

**Top Spatter (Dross)**

Top spatter or dross on the top of the cut caused by slow travel speed, excess cutting height, or cutting tip whose orifice has become elongated.

**4T.05 General Cutting Information**



**WARNING**

Disconnect primary power at the source before disassembling the power supply, torch, or torch leads.

Frequently review the Important Safety Precautions at the front of this manual. Be sure the operator is equipped with proper gloves, clothing, eye and ear protection. Make sure no part of the operator's body comes into contact with the workpiece while the torch is activated.



**CAUTION**

Sparks from the cutting process can cause damage to coated, painted, and other surfaces such as glass, plastic and metal.



**NOTE!**

Handle torch leads with care and protect them from damage.

**Piloting**

Piloting is harder on parts life than actual cutting because the pilot arc is directed from the electrode to the tip rather than to a workpiece. Whenever possible, avoid excessive pilot arc time to improve parts life.

**Torch Standoff**

Improper standoff (the distance between the torch tip and workpiece) can adversely affect tip life as well as shield cup life. Standoff may also significantly affect the bevel angle. Reducing standoff will generally result in a more square cut.

**Edge Starting**

For edge starts, hold the torch perpendicular to the workpiece with the front of the tip near (not touching) the edge of the workpiece at the point where the cut is to start. When starting at the edge of the plate, do not pause at the edge and force the arc to "reach" for the edge of the metal. Establish the cutting arc as quickly as possible.

**Direction of Cut**

In the torches, the plasma gas stream swirls as it leaves the torch to maintain a smooth column of gas. This swirl effect results in one side of a cut being more square than the other. Viewed along the direction of travel, the right side of the cut is more square than the left.

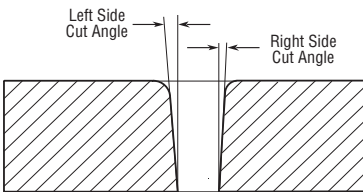

*Side Characteristics Of Cut*

To make a square - edged cut along an inside diameter of a circle, the torch should move counterclockwise around the circle. To keep the square edge along an outside diameter cut, the torch should travel in a clockwise direction.

**Dross**

When dross is present on carbon steel, it is commonly referred to as either "high speed, slow speed, or top dross". Dross present on top of the plate is normally caused by too great a torch to plate distance. "Top dross" is normally very easy to remove and can often be wiped off with a welding glove. "Slow speed dross" is normally present on the bottom edge of the plate. It can vary from a light to heavy bead, but does not adhere tightly to the cut edge, and can be easily scraped off. "High speed dross" usually forms a narrow bead along the bottom of the cut edge and is very difficult to remove. When cutting a troublesome steel, it is sometimes useful to reduce the cutting speed to produce "slow speed dross". Any resultant cleanup can be accomplished by scraping, not grinding.

**4T.06 Hand Torch Operation**

**Standoff Cutting With Hand Torch**



**NOTE!**

For best performance and parts life, always use the correct parts for the type of operation.

1. The torch can be comfortably held in one hand or steadied with two hands. Position the hand to press the Trigger on the torch handle. With the hand torch, the hand may be positioned close to the torch head for maximum control or near the back end for maximum heat protection. Choose the holding technique that feels most comfortable and allows good control and movement.



**NOTE!**

The tip should never come in contact with the workpiece except during drag cutting operations.

2. Depending on the cutting operation, do one of the following:
  - a. For **edge starts**, hold the torch perpendicular to the workpiece with the front of the tip on the edge

of the workpiece at the point where the cut is to start.

- b. For **standoff cutting**, hold the torch 1/8 - 3/8 in (3-9 mm) from the workpiece as shown below.

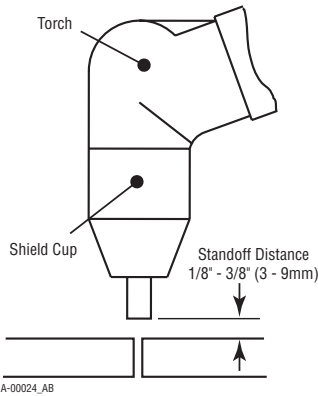

A-00024\_AB

Standoff Distance

3. Hold the torch away from your body.
4. Slide the trigger release toward the back of the torch handle while simultaneously squeezing the trigger. The pilot arc will start.

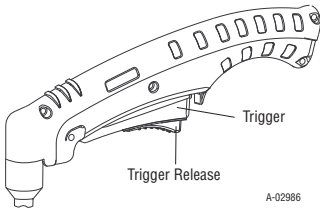

A-02986

5. Bring the torch within transfer distance to the work. The main arc will transfer to the work, and the pilot arc will shut OFF.



**NOTE!**

The gas preflow and postflow are a characteristic of the power supply and not a function of the torch.

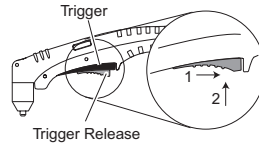

Trigger Release

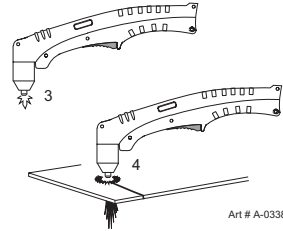

Art # A-03383

6. Cut as usual. Simply release the trigger assembly to stop cutting.
7. Follow normal recommended cutting practices as provided in the power supply operator's manual.



**NOTE!**

When the shield cup is properly installed, there is a slight gap between the shield cup and the torch handle. Gas vents through this gap as part of normal operation. Do not attempt to force the shield cup to close this gap. Forcing the shield cup against the torch head or torch handle can damage components.

8. For a consistent standoff height from the workpiece, install the standoff guide by sliding it onto the torch shield cup. In-stall the guide with the legs at the sides of the shield cup body to maintain good visibility of the cutting arc. During operation, position the legs of the standoff guide against the workpiece.

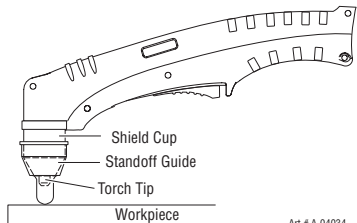

Art # A-04034

**Shield Cup With Straight Edge**

The drag shield cup can be used with a non conductive straight edge to make straight cuts by hand.



**WARNING**  
The straight edge **must be** non - conductive.

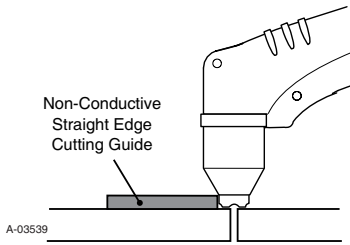

*Using Drag Shield Cup With Straight Edge*

The crown shield cup functions best when cutting 3/16 inch (4.7 mm) solid metal with relatively smooth surface.

### Drag Cutting With a Hand Torch

Drag cutting works best on metal 1/4" (6 mm) thick or less.



**NOTE!**  
For best parts performance and life, always use the correct parts for the type of operation.

1. Install the drag cutting tip and set the output current.
2. The torch can be comfortably held in one hand or steadied with two hands. Position the hand to press the Trigger on the torch handle. With the hand torch, the hand may be positioned close to the torch head for maximum control or near the back end for maximum heat protection. Choose the holding technique that feels most comfortable and allows good control and movement.
3. Keep the torch in contact with the work-piece during the cutting cycle.
4. Hold the torch away from your body.
5. Slide the trigger release toward the back of the torch handle while simultaneously squeezing the trigger. The pilot arc will start.

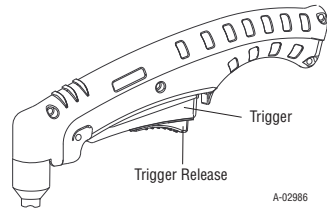

6. Bring the torch within transfer distance to the work. The main arc will transfer to the work, and the pilot arc will shut OFF.



**NOTE!**  
The gas preflow and postflow are a characteristic of the power supply and not a function of the torch.

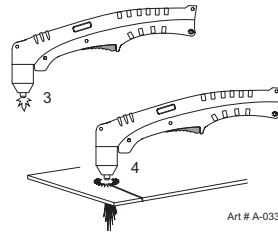
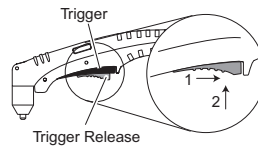

7. Cut as usual. Simply release the trigger assembly to stop cutting.
8. Follow normal recommended cutting practices as provided in the power supply operator's manual.



**NOTE!**  
When the shield cup is properly installed, there is a slight gap between the shield cup and the torch handle. Gas vents through this gap as part of normal operation. Do not attempt to force the shield cup to close this gap. Forcing the shield cup against the torch head or torch handle can damage components.

### Piercing With Hand Torch

1. The torch can be comfortably held in one hand or steadied with two hands. Position the hand to press the Trigger on the torch handle. With the hand torch, the hand may be positioned close to the torch head for maximum control or



near the back end for maximum heat protection. Choose the technique that feels most comfortable and allows good control and movement.

**NOTE!**

The tip should never come in contact with the workpiece except during drag cutting operations.

2. Angle the torch slightly to direct blow-back particles away from the torch tip (and operator) rather than directly back into it until the pierce is complete.
3. In a portion of the unwanted metal start the pierce off the cutting line and then continue the cut onto the line. Hold the torch perpendicular to the workpiece after the pierce is complete.
4. Hold the torch away from your body.
5. Slide the trigger release toward the back of the torch handle while simultaneously squeezing the trigger. The pilot arc will start.

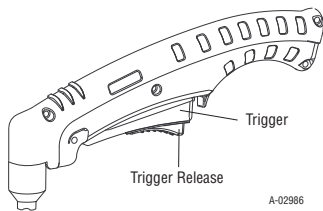

6. Bring the torch within transfer distance to the work. The main arc will transfer to the work, and the pilot arc will shut OFF.

**NOTE!**

The gas preflow and postflow are a characteristic of the power supply and not a function of the torch.

When the shield cup is properly installed, there is a slight gap between the shield cup and the torch handle. Gas vents through this gap as part of normal operation. Do not attempt to force the shield cup to close this gap. Forcing the shield cup against the torch head or torch handle can damage components.

7. Clean spatter and scale from the shield cup and the tip as soon as possible. Spraying the shield cup in anti-spatter compound will minimize the amount of scale which adheres to it.

Cutting speed depends on material, thickness, and the operator's ability to accurately follow the desired cut line. The following factors may have an impact on system performance:

- Torch parts wear
- Air quality
- Line voltage fluctuations
- Torch standoff height
- Proper work cable connection

**4T.07 Gouging****WARNING**

Be sure the operator is equipped with proper gloves, clothing, eye and ear protection and that all safety precautions at the front of this manual have been followed. Make sure no part of the operator's body comes in contact with the workpiece when the torch is activated. Disconnect primary power to the system before disassembling the torch, leads, or power supply.

**CAUTION**

Sparks from plasma gouging can cause damage to coated, painted or other surfaces such as glass, plastic, and metal. Check torch parts. The torch parts must correspond with the type of operation. Refer to Section "4T.03 Machine and Hand Torch Parts Selection".

**Gouging Parameters**

Gouging performance depends on parameters such as torch travel speed, current level, lead angle (the angle between the torch and workpiece), and the distance between the torch tip and workpiece (standoff).

**CAUTION**

Touching the torch tip or shield cup to the work surface will cause excessive parts wear.

**Torch Travel Speed****NOTE!**

Refer to Appendix Pages for additional information as related to the Power Supply used.

Optimum torch travel speed is dependent on current setting, lead angle, and mode of operation (hand or machine torch).

**Current Setting**

Current settings depend on torch travel speed, mode of operation (hand or machine torch), and the amount of material to be removed.

**Lead Angle**

The angle between the torch and workpiece depends on the output current setting and torch travel speed. The recommended lead angle is 35°. At a lead angle greater than 45° the molten metal will not be blown out of the gouge and may be blown back onto the torch. If the lead angle is too small (less than 35°), less material may be removed, requiring more passes. In some applications, such as removing welds or working with light metal, this may be desirable.

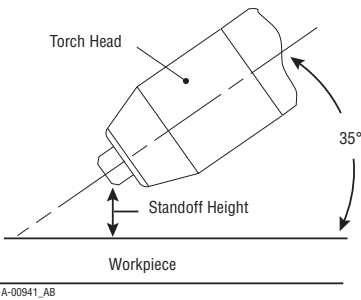

*Gouging Angle and Standoff Distance*

**Standoff Distance**

The tip to work distance affects gouge quality and depth. Standoff distance of 1/8 - 1/4 inch (3 - 6 mm) allows for smooth, consistent metal removal. Smaller standoff distances may result in a severance cut rather than a gouge. Standoff distances greater than 1/4 inch (6 mm) may result in minimal metal removal or loss of transferred main arc.

**Slag Buildup**

Slag generated by gouging on materials such as carbon and stainless steels, nickels, and alloyed steels, can be removed easily in most cases. Slag does not obstruct the gouging process if it accumulates to the side of the gouge path. However, slag build - up can cause inconsistencies and irregular metal removal if large amounts of material build up in front of the arc. The build - up is most often a result of improper travel speed, lead angle, or standoff height.

This Page Intentionally Blank

**4T.08 Recommended Cutting Speeds for Machine and Automated Torches With Exposed Tip**

| Torch With Exposed Tip |      |            |             |          |                    | Type Material: Mild Steel            |          |     |                     |     |            |         |             |               |     |
|------------------------|------|------------|-------------|----------|--------------------|--------------------------------------|----------|-----|---------------------|-----|------------|---------|-------------|---------------|-----|
| Type Plasma Gas: Air   |      |            |             |          |                    | Type Secondary Gas: Single Gas Torch |          |     |                     |     |            |         |             |               |     |
| Thickness              |      | Tip        | Output      | Amperage | Speed (Per Minute) |                                      | Standoff |     | Plasma Gas Pressure |     | Flow (CFH) |         | Pierce      | Pierce Height |     |
| Inches                 | mm   | (Cat. No.) | Volts (VDC) | (Amps)   | Inches             | Meters                               | Inches   | mm  | psi*                | bar | Plasma     | Total** | Delay (Sec) | Inches        | mm  |
| 0.036                  | 0.9  | 9-8207     | 104         | 40       | 340                | 8.64                                 | 0.19     | 4.8 | 70                  | 4.8 | 55         | 170     | 0           | 0.2           | 5.1 |
| 0.06                   | 1.5  | 9-8207     | 108         | 40       | 250                | 6.35                                 | 0.19     | 4.8 | 70                  | 4.8 | 55         | 170     | 0.1         | 0.2           | 5.1 |
| 0.075                  | 1.9  | 9-8207     | 108         | 40       | 190                | 4.83                                 | 0.19     | 4.8 | 70                  | 4.8 | 55         | 170     | 0.3         | 0.2           | 5.1 |
| 0.135                  | 3.4  | 9-8207     | 110         | 40       | 105                | 2.67                                 | 0.19     | 4.8 | 70                  | 4.8 | 55         | 170     | 0.4         | 0.2           | 5.1 |
| 0.188                  | 4.8  | 9-8207     | 113         | 40       | 60                 | 1.52                                 | 0.19     | 4.8 | 70                  | 4.8 | 55         | 170     | 0.6         | 0.2           | 5.1 |
| 0.25                   | 6.4  | 9-8207     | 111         | 40       | 40                 | 1.02                                 | 0.19     | 4.8 | 70                  | 4.8 | 55         | 170     | 1           | 0.2           | 5.1 |
| 0.375                  | 9.5  | 9-8207     | 124         | 40       | 21                 | 0.53                                 | 0.19     | 4.8 | 70                  | 4.8 | 55         | 170     | NR          | NR            | NR  |
| 0.5                    | 12.7 | 9-8207     | 123         | 40       | 11                 | 0.28                                 | 0.19     | 4.8 | 70                  | 4.8 | 55         | 170     | NR          | NR            | NR  |
| 0.625                  | 15.9 | 9-8207     | 137         | 40       | 7                  | 0.18                                 | 0.19     | 4.8 | 70                  | 4.8 | 55         | 170     | NR          | NR            | NR  |

| Torch With Exposed Tip |     |            |             |          |                    | Type Material: Stainless Steel       |          |     |                     |     |            |         |             |               |     |
|------------------------|-----|------------|-------------|----------|--------------------|--------------------------------------|----------|-----|---------------------|-----|------------|---------|-------------|---------------|-----|
| Type Plasma Gas: Air   |     |            |             |          |                    | Type Secondary Gas: Single Gas Torch |          |     |                     |     |            |         |             |               |     |
| Thickness              |     | Tip        | Output      | Amperage | Speed (Per Minute) |                                      | Standoff |     | Plasma Gas Pressure |     | Flow (CFH) |         | Pierce      | Pierce Height |     |
| Inches                 | mm  | (Cat. No.) | Volts (VDC) | (Amps)   | Inches             | Meters                               | Inches   | mm  | psi*                | bar | Plasma     | Total** | Delay (Sec) | Inches        | mm  |
| 0.036                  | 0.9 | 9-8207     | 103         | 40       | 355                | 9.02                                 | 0.125    | 3.2 | 70                  | 4.8 | 55         | 170     | 0           | 0.2           | 5.1 |
| 0.05                   | 1.3 | 9-8207     | 98          | 40       | 310                | 7.87                                 | 0.125    | 3.2 | 70                  | 4.8 | 55         | 170     | 0           | 0.2           | 5.1 |
| 0.06                   | 1.5 | 9-8207     | 98          | 40       | 240                | 6.1                                  | 0.125    | 3.2 | 70                  | 4.8 | 55         | 170     | 0.1         | 0.2           | 5.1 |
| 0.078                  | 2   | 9-8207     | 100         | 40       | 125                | 3.18                                 | 0.125    | 3.2 | 70                  | 4.8 | 55         | 170     | 0.3         | 0.2           | 5.1 |
| 0.135                  | 3.4 | 9-8207     | 120         | 40       | 30                 | 0.76                                 | 0.187    | 4.8 | 70                  | 4.8 | 55         | 170     | 0.4         | 0.2           | 5.1 |
| 0.188                  | 4.8 | 9-8207     | 124         | 40       | 20                 | 0.51                                 | 0.187    | 4.8 | 70                  | 4.8 | 55         | 170     | 0.6         | 0.2           | 5.1 |
| 0.25                   | 6.4 | 9-8207     | 122         | 40       | 15                 | 0.38                                 | 0.187    | 4.8 | 70                  | 4.8 | 55         | 170     | 1           | 0.2           | 5.1 |
| 0.375                  | 9.5 | 9-8207     | 126         | 40       | 10                 | 0.25                                 | 0.187    | 4.8 | 70                  | 4.8 | 55         | 170     | NR          | NR            | NR  |

| Torch With Exposed Tip |     |            |             |          |                    | Type Material: Aluminum              |          |     |                     |     |            |         |             |               |     |
|------------------------|-----|------------|-------------|----------|--------------------|--------------------------------------|----------|-----|---------------------|-----|------------|---------|-------------|---------------|-----|
| Type Plasma Gas: Air   |     |            |             |          |                    | Type Secondary Gas: Single Gas Torch |          |     |                     |     |            |         |             |               |     |
| Thickness              |     | Tip        | Output      | Amperage | Speed (Per Minute) |                                      | Standoff |     | Plasma Gas Pressure |     | Flow (CFH) |         | Pierce      | Pierce Height |     |
| Inches                 | mm  | (Cat. No.) | Volts (VDC) | (Amps)   | Inches             | Meters                               | Inches   | mm  | psi*                | bar | Plasma     | Total** | Delay (Sec) | Inches        | mm  |
| 0.032                  | 0.8 | 9-8207     | 110         | 40       | 440                | 11.18                                | 0.187    | 4.8 | 70                  | 4.8 | 55         | 170     | 0           | 0.2           | 5.1 |
| 0.051                  | 1.3 | 9-8207     | 109         | 40       | 350                | 8.89                                 | 0.187    | 4.8 | 70                  | 4.8 | 55         | 170     | 0.1         | 0.2           | 5.1 |
| 0.064                  | 1.6 | 9-8207     | 112         | 40       | 250                | 6.35                                 | 0.187    | 4.8 | 70                  | 4.8 | 55         | 170     | 0.1         | 0.2           | 5.1 |
| 0.079                  | 2   | 9-8207     | 112         | 40       | 200                | 5.08                                 | 0.19     | 4.8 | 70                  | 4.8 | 55         | 170     | 0.3         | 0.2           | 5.1 |
| 0.125                  | 3.2 | 9-8207     | 118         | 40       | 100                | 2.54                                 | 0.19     | 4.8 | 70                  | 4.8 | 55         | 170     | 0.4         | 0.2           | 5.1 |
| 0.188                  | 4.8 | 9-8207     | 120         | 40       | 98                 | 2.49                                 | 0.187    | 4.8 | 70                  | 4.8 | 55         | 170     | 0.6         | 0.2           | 5.1 |
| 0.25                   | 6.4 | 9-8207     | 123         | 40       | 50                 | 1.27                                 | 0.187    | 4.8 | 70                  | 4.8 | 55         | 170     | 1           | 0.2           | 5.1 |
| 0.375                  | 9.5 | 9-8207     | 134         | 40       | 16                 | 0.41                                 | 0.187    | 4.8 | 70                  | 4.8 | 55         | 170     | NR          | NR            | NR  |

| Torch With Exposed Tip |      |            |             |          |                    |        | Type Material: Mild Steel            |     |                     |     |            |         |             |               |     |
|------------------------|------|------------|-------------|----------|--------------------|--------|--------------------------------------|-----|---------------------|-----|------------|---------|-------------|---------------|-----|
| Type Plasma Gas: Air   |      |            |             |          |                    |        | Type Secondary Gas: Single Gas Torch |     |                     |     |            |         |             |               |     |
| Thickness              |      | Tip        | Output      | Amperage | Speed (Per Minute) |        | Standoff                             |     | Plasma Gas Pressure |     | Flow (CFH) |         | Pierce      | Pierce Height |     |
| Inches                 | mm   | (Cat. No.) | Volts (VDC) | (Amps)   | Inches             | Meters | Inches                               | mm  | psi*                | bar | Plasma     | Total** | Delay (Sec) | Inches        | mm  |
| 0.06                   | 1.5  | 9-8209     | 109         | 50       | 270                | 6.86   | 0.19                                 | 4.8 | 75                  | 5.2 | 90         | 245     | 0           | 0.19          | 4.8 |
| 0.075                  | 1.9  | 9-8209     | 114         | 50       | 238                | 6.04   | 0.19                                 | 4.8 | 75                  | 5.2 | 90         | 245     | 0.1         | 0.19          | 4.8 |
| 0.135                  | 3.4  | 9-8209     | 115         | 50       | 138                | 3.50   | 0.19                                 | 4.8 | 75                  | 5.2 | 90         | 245     | 0.1         | 0.19          | 4.8 |
| 0.188                  | 4.8  | 9-8209     | 117         | 50       | 80                 | 2.03   | 0.19                                 | 4.8 | 75                  | 5.2 | 90         | 245     | 0.2         | 0.19          | 4.8 |
| 0.25                   | 6.4  | 9-8209     | 115         | 50       | 60                 | 1.53   | 0.19                                 | 4.8 | 75                  | 5.2 | 90         | 245     | 0.3         | 0.19          | 4.8 |
| 0.375                  | 9.5  | 9-8209     | 124         | 50       | 36                 | 0.90   | 0.19                                 | 4.8 | 75                  | 5.2 | 90         | 245     | 0.5         | 0.19          | 4.8 |
| 0.5                    | 12.7 | 9-8209     | 125         | 50       | 19                 | 0.47   | 0.19                                 | 4.8 | 75                  | 5.2 | 90         | 245     | 0.75        | 0.19          | 4.8 |
| 0.625                  | 15.9 | 9-8209     | 132         | 50       | 13                 | 0.33   | 0.19                                 | 4.8 | 75                  | 5.2 | 90         | 245     | NR          | NR            | NR  |

| Torch With Exposed Tip |     |            |             |          |                    |        | Type Material: Stainless Steel       |     |                     |     |            |         |             |               |     |
|------------------------|-----|------------|-------------|----------|--------------------|--------|--------------------------------------|-----|---------------------|-----|------------|---------|-------------|---------------|-----|
| Type Plasma Gas: Air   |     |            |             |          |                    |        | Type Secondary Gas: Single Gas Torch |     |                     |     |            |         |             |               |     |
| Thickness              |     | Tip        | Output      | Amperage | Speed (Per Minute) |        | Standoff                             |     | Plasma Gas Pressure |     | Flow (CFH) |         | Pierce      | Pierce Height |     |
| Inches                 | mm  | (Cat. No.) | Volts (VDC) | (Amps)   | Inches             | Meters | Inches                               | mm  | psi*                | bar | Plasma     | Total** | Delay (Sec) | Inches        | mm  |
| 0.06                   | 1.5 | 9-8209     | 109         | 50       | 295                | 7.51   | 0.19                                 | 4.8 | 75                  | 5.2 | 90         | 245     | 0           | 0.2           | 5.1 |
| 0.075                  | 1.9 | 9-8209     | 108         | 50       | 213                | 5.41   | 0.19                                 | 4.8 | 75                  | 5.2 | 90         | 245     | 0.1         | 0.2           | 5.1 |
| 0.135                  | 3.4 | 9-8209     | 119         | 50       | 78                 | 1.97   | 0.19                                 | 4.8 | 75                  | 5.2 | 90         | 245     | 0.1         | 0.2           | 5.1 |
| 0.188                  | 4.8 | 9-8209     | 123         | 50       | 55                 | 1.40   | 0.19                                 | 4.8 | 75                  | 5.2 | 90         | 245     | 0.2         | 0.2           | 5.1 |
| 0.25                   | 6.4 | 9-8209     | 121         | 50       | 40                 | 1.02   | 0.19                                 | 4.8 | 75                  | 5.2 | 90         | 245     | 0.3         | 0.2           | 5.1 |
| 0.375                  | 9.5 | 9-8209     | 128         | 50       | 20                 | 0.51   | 0.19                                 | 4.8 | 75                  | 5.2 | 90         | 245     | 0.5         | 0.2           | 5.1 |

| Torch With Exposed Tip |     |            |             |          |                    |        | Type Material: Aluminum              |     |                     |     |            |         |             |               |     |
|------------------------|-----|------------|-------------|----------|--------------------|--------|--------------------------------------|-----|---------------------|-----|------------|---------|-------------|---------------|-----|
| Type Plasma Gas: Air   |     |            |             |          |                    |        | Type Secondary Gas: Single Gas Torch |     |                     |     |            |         |             |               |     |
| Thickness              |     | Tip        | Output      | Amperage | Speed (Per Minute) |        | Standoff                             |     | Plasma Gas Pressure |     | Flow (CFH) |         | Pierce      | Pierce Height |     |
| Inches                 | mm  | (Cat. No.) | Volts (VDC) | (Amps)   | Inches             | Meters | Inches                               | mm  | psi*                | bar | Plasma     | Total** | Delay (Sec) | Inches        | mm  |
| 0.06                   | 1.5 | 9-8209     | 111         | 50       | 345                | 8.77   | 0.25                                 | 6.4 | 75                  | 5.2 | 90         | 245     | 0           | 0.25          | 6.4 |
| 0.075                  | 1.9 | 9-8209     | 111         | 50       | 320                | 8.13   | 0.25                                 | 6.4 | 75                  | 5.2 | 90         | 245     | 0.1         | 0.25          | 6.4 |
| 0.12                   | 3   | 9-8209     | 117         | 50       | 175                | 4.45   | 0.25                                 | 6.4 | 75                  | 5.2 | 90         | 245     | 0.1         | 0.25          | 6.4 |
| 0.188                  | 3.4 | 9-8209     | 118         | 50       | 134                | 3.41   | 0.25                                 | 6.4 | 75                  | 5.2 | 90         | 245     | 0.2         | 0.25          | 6.4 |
| 0.25                   | 6.4 | 9-8209     | 128         | 50       | 68                 | 1.72   | 0.25                                 | 6.4 | 75                  | 5.2 | 90         | 245     | 0.3         | 0.25          | 6.4 |
| 0.375                  | 9.5 | 9-8209     | 137         | 50       | 31                 | 0.78   | 0.25                                 | 6.4 | 75                  | 5.2 | 90         | 245     | 0.5         | 0.25          | 6.4 |

## 4T.09 Recommended Cutting Speeds for Machine and Automated Torches With Shielded Tip

| Torch With Shielded Tip |      |            |             |          |                    | Type Material: Mild Steel            |          |     |                     |     |            |         |             |               |     |
|-------------------------|------|------------|-------------|----------|--------------------|--------------------------------------|----------|-----|---------------------|-----|------------|---------|-------------|---------------|-----|
| Type Plasma Gas: Air    |      |            |             |          |                    | Type Secondary Gas: Single Gas Torch |          |     |                     |     |            |         |             |               |     |
| Thickness               |      | Tip        | Output      | Amperage | Speed (Per Minute) |                                      | Standoff |     | Plasma Gas Pressure |     | Flow (CFH) |         | Pierce      | Pierce Height |     |
| Inches                  | mm   | (Cat. No.) | Volts (VDC) | (Amps)   | Inches             | Meters                               | Inches   | mm  | psi*                | bar | Plasma     | Total** | Delay (Sec) | Inches        | mm  |
| 0.036                   | 0.9  | 9-8207     | 114         | 40       | 170                | 4.32                                 | 0.19     | 4.8 | 70                  | 4.8 | 55         | 170     | 0           | 0.2           | 5.1 |
| 0.06                    | 1.5  | 9-8207     | 120         | 40       | 90                 | 2.29                                 | 0.19     | 4.8 | 70                  | 4.8 | 55         | 170     | 0.1         | 0.2           | 5.1 |
| 0.075                   | 1.9  | 9-8207     | 121         | 40       | 80                 | 2.03                                 | 0.19     | 4.8 | 70                  | 4.8 | 55         | 170     | 0.3         | 0.2           | 5.1 |
| 0.135                   | 3.4  | 9-8207     | 122         | 40       | 75                 | 1.91                                 | 0.19     | 4.8 | 70                  | 4.8 | 55         | 170     | 0.4         | 0.2           | 5.1 |
| 0.135                   | 3.4  | 9-8207     | 122         | 40       | 75                 | 1.91                                 | 0.19     | 4.8 | 70                  | 4.8 | 55         | 170     | 0.4         | 0.2           | 5.1 |
| 0.188                   | 4.8  | 9-8207     | 123         | 40       | 30                 | 0.76                                 | 0.19     | 4.8 | 70                  | 4.8 | 55         | 170     | 0.6         | 0.2           | 5.1 |
| 0.25                    | 6.4  | 9-8207     | 125         | 40       | 25                 | 0.64                                 | 0.19     | 4.8 | 70                  | 4.8 | 55         | 170     | 1           | 0.2           | 5.1 |
| 0.375                   | 9.5  | 9-8207     | 138         | 40       | 11                 | 0.28                                 | 0.19     | 4.8 | 70                  | 4.8 | 55         | 170     | NR          | NR            | NR  |
| 0.5                     | 12.7 | 9-8207     | 142         | 40       | 7                  | 0.18                                 | 0.19     | 4.8 | 70                  | 4.8 | 55         | 170     | NR          | NR            | NR  |
| 0.625                   | 15.9 | 9-8207     | 152         | 40       | 3                  | 0.08                                 | 0.19     | 4.8 | 70                  | 4.8 | 55         | 170     | NR          | NR            | NR  |

| Torch With Shielded Tip |     |            |             |          |                    | Type Material: Stainless Steel       |          |     |                     |     |            |         |             |               |     |
|-------------------------|-----|------------|-------------|----------|--------------------|--------------------------------------|----------|-----|---------------------|-----|------------|---------|-------------|---------------|-----|
| Type Plasma Gas: Air    |     |            |             |          |                    | Type Secondary Gas: Single Gas Torch |          |     |                     |     |            |         |             |               |     |
| Thickness               |     | Tip        | Output      | Amperage | Speed (Per Minute) |                                      | Standoff |     | Plasma Gas Pressure |     | Flow (CFH) |         | Pierce      | Pierce Height |     |
| Inches                  | mm  | (Cat. No.) | Volts (VDC) | (Amps)   | Inches             | Meters                               | Inches   | mm  | psi*                | bar | Plasma     | Total** | Delay (Sec) | Inches        | mm  |
| 0.036                   | 0.9 | 9-8207     | 109         | 40       | 180                | 4.57                                 | 0.125    | 3.2 | 70                  | 4.8 | 55         | 170     | 0           | 0.2           | 5.1 |
| 0.05                    | 1.3 | 9-8207     | 105         | 40       | 165                | 4.19                                 | 0.125    | 3.2 | 70                  | 4.8 | 55         | 170     | 0           | 0.2           | 5.1 |
| 0.06                    | 1.5 | 9-8207     | 115         | 40       | 120                | 3.05                                 | 0.125    | 3.2 | 70                  | 4.8 | 55         | 170     | 0.1         | 0.2           | 5.1 |
| 0.078                   | 2   | 9-8207     | 120         | 40       | 65                 | 1.65                                 | 0.187    | 4.8 | 70                  | 4.8 | 55         | 170     | 0.3         | 0.2           | 5.1 |
| 0.135                   | 3.4 | 9-8207     | 125         | 40       | 25                 | 0.64                                 | 0.187    | 4.8 | 70                  | 4.8 | 55         | 170     | 0.4         | 0.2           | 5.1 |
| 0.188                   | 4.8 | 9-8207     | 132         | 40       | 20                 | 0.51                                 | 0.187    | 4.8 | 70                  | 4.8 | 55         | 170     | 0.6         | 0.2           | 5.1 |
| 0.25                    | 6.4 | 9-8207     | 130         | 40       | 15                 | 0.38                                 | 0.187    | 4.8 | 70                  | 4.8 | 55         | 170     | 1           | 0.2           | 5.1 |
| 0.375                   | 9.5 | 9-8207     | 130         | 40       | 10                 | 0.25                                 | 0.187    | 4.8 | 70                  | 4.8 | 55         | 170     | NR          | NR            | NR  |

| Torch With Shielded Tip |     |            |             |          |                    | Type Material: Aluminum              |          |     |                     |     |            |         |             |               |     |
|-------------------------|-----|------------|-------------|----------|--------------------|--------------------------------------|----------|-----|---------------------|-----|------------|---------|-------------|---------------|-----|
| Type Plasma Gas: Air    |     |            |             |          |                    | Type Secondary Gas: Single Gas Torch |          |     |                     |     |            |         |             |               |     |
| Thickness               |     | Tip        | Output      | Amperage | Speed (Per Minute) |                                      | Standoff |     | Plasma Gas Pressure |     | Flow (CFH) |         | Pierce      | Pierce Height |     |
| Inches                  | mm  | (Cat. No.) | Volts (VDC) | (Amps)   | Inches             | Meters                               | Inches   | mm  | psi*                | bar | Plasma     | Total** | Delay (Sec) | Inches        | mm  |
| 0.032                   | 0.8 | 9-8207     | 116         | 40       | 220                | 5.59                                 | 0.187    | 4.8 | 70                  | 4.8 | 55         | 170     | 0           | 0.2           | 5.1 |
| 0.051                   | 1.3 | 9-8207     | 116         | 40       | 210                | 5.33                                 | 0.187    | 4.8 | 70                  | 4.8 | 55         | 170     | 0           | 0.2           | 5.1 |
| 0.064                   | 1.6 | 9-8207     | 118         | 40       | 180                | 4.57                                 | 0.187    | 4.8 | 70                  | 4.8 | 55         | 170     | 0.1         | 0.2           | 5.1 |
| 0.079                   | 2   | 9-8207     | 116         | 40       | 150                | 3.81                                 | 0.19     | 4.8 | 70                  | 4.8 | 55         | 170     | 0.3         | 0.2           | 5.1 |
| 0.125                   | 3.2 | 9-8207     | 130         | 40       | 75                 | 1.91                                 | 0.19     | 4.8 | 70                  | 4.8 | 55         | 170     | 0.4         | 0.2           | 5.1 |
| 0.188                   | 4.8 | 9-8207     | 132         | 40       | 60                 | 1.52                                 | 0.187    | 4.8 | 70                  | 4.8 | 55         | 170     | 0.6         | 0.2           | 5.1 |
| 0.25                    | 6.4 | 9-8207     | 134         | 40       | 28                 | 0.71                                 | 0.187    | 4.8 | 70                  | 4.8 | 55         | 170     | 1           | 0.2           | 5.1 |
| 0.375                   | 9.5 | 9-8207     | 143         | 40       | 11                 | 0.28                                 | 0.187    | 4.8 | 70                  | 4.8 | 55         | 170     | NR          | NR            | NR  |

| Torch With Shielded Tip |      |            |             |          |                    |        | Type Material: Mild Steel            |     |                     |     |            |         |             |               |     |
|-------------------------|------|------------|-------------|----------|--------------------|--------|--------------------------------------|-----|---------------------|-----|------------|---------|-------------|---------------|-----|
| Type Plasma Gas: Air    |      |            |             |          |                    |        | Type Secondary Gas: Single Gas Torch |     |                     |     |            |         |             |               |     |
| Thickness               |      | Tip        | Output      | Amperage | Speed (Per Minute) |        | Standoff                             |     | Plasma Gas Pressure |     | Flow (CFH) |         | Pierce      | Pierce Height |     |
| Inches                  | mm   | (Cat. No.) | Volts (VDC) | (Amps)   | Inches             | Meters | Inches                               | mm  | psi*                | bar | Plasma     | Total** | Delay (Sec) | Inches        | mm  |
| 0.06                    | 1.5  | 9-8209     | 122         | 50       | 170                | 4.32   | 0.19                                 | 4.8 | 75                  | 5.2 | 90         | 245     | 0           | 0.2           | 5.1 |
| 0.075                   | 1.9  | 9-8209     | 124         | 50       | 159                | 4.03   | 0.19                                 | 4.8 | 75                  | 5.2 | 90         | 245     | 0.1         | 0.2           | 5.1 |
| 0.12                    | 3    | 9-8209     | 124         | 50       | 153                | 3.88   | 0.19                                 | 4.8 | 75                  | 5.2 | 90         | 245     | 0.1         | 0.2           | 5.1 |
| 0.135                   | 3.4  | 9-8209     | 125         | 50       | 109                | 2.76   | 0.19                                 | 4.8 | 75                  | 5.2 | 90         | 245     | 0.1         | 0.2           | 5.1 |
| 0.188                   | 4.8  | 9-8209     | 126         | 50       | 78                 | 1.97   | 0.19                                 | 4.8 | 75                  | 5.2 | 90         | 245     | 0.2         | 0.2           | 5.1 |
| 0.25                    | 6.4  | 9-8209     | 124         | 50       | 53                 | 1.34   | 0.19                                 | 4.8 | 75                  | 5.2 | 90         | 245     | 0.3         | 0.2           | 5.1 |
| 0.375                   | 9.5  | 9-8209     | 135         | 50       | 23                 | 0.57   | 0.19                                 | 4.8 | 75                  | 5.2 | 90         | 245     | 0.5         | 0.2           | 5.1 |
| 0.5                     | 12.7 | 9-8209     | 140         | 50       | 15                 | 0.38   | 0.19                                 | 4.8 | 75                  | 5.2 | 90         | 245     | 0.75        | 0.2           | 5.1 |
| 0.625                   | 15.9 | 9-8209     | 146         | 50       | 9                  | 0.22   | 0.19                                 | 4.8 | 75                  | 5.2 | 90         | 245     | NR          | NR            | NR  |

| Torch With Shielded Tip |     |            |             |          |                    |        | Type Material: Stainless Steel       |     |                     |     |            |         |             |               |     |
|-------------------------|-----|------------|-------------|----------|--------------------|--------|--------------------------------------|-----|---------------------|-----|------------|---------|-------------|---------------|-----|
| Type Plasma Gas: Air    |     |            |             |          |                    |        | Type Secondary Gas: Single Gas Torch |     |                     |     |            |         |             |               |     |
| Thickness               |     | Tip        | Output      | Amperage | Speed (Per Minute) |        | Standoff                             |     | Plasma Gas Pressure |     | Flow (CFH) |         | Pierce      | Pierce Height |     |
| Inches                  | mm  | (Cat. No.) | Volts (VDC) | (Amps)   | Inches             | Meters | Inches                               | mm  | psi*                | bar | Plasma     | Total** | Delay (Sec) | Inches        | mm  |
| 0.06                    | 1.5 | 9-8209     | 113         | 50       | 143                | 3.62   | 0.13                                 | 3.2 | 75                  | 5.2 | 90         | 245     | 0           | 0.2           | 5.1 |
| 0.075                   | 1.9 | 9-8209     | 118         | 50       | 110                | 2.80   | 0.13                                 | 3.2 | 75                  | 5.2 | 90         | 245     | 0.1         | 0.2           | 5.1 |
| 0.135                   | 3.4 | 9-8209     | 122         | 50       | 53                 | 1.34   | 0.13                                 | 3.2 | 75                  | 5.2 | 90         | 245     | 0.1         | 0.2           | 5.1 |
| 0.188                   | 4.8 | 9-8209     | 126         | 50       | 48                 | 1.21   | 0.13                                 | 3.2 | 75                  | 5.2 | 90         | 245     | 0.2         | 0.2           | 5.1 |
| 0.25                    | 6.4 | 9-8209     | 126         | 50       | 38                 | 0.95   | 0.13                                 | 3.2 | 75                  | 5.2 | 90         | 245     | 0.3         | 0.2           | 5.1 |
| 0.375                   | 9.5 | 9-8209     | 130         | 50       | 19                 | 0.48   | 0.13                                 | 3.2 | 75                  | 5.2 | 90         | 245     | 0.5         | 0.2           | 5.1 |

| Torch With Shielded Tip |     |            |             |          |                    |        | Type Material: Aluminum              |     |                     |     |            |         |             |               |     |
|-------------------------|-----|------------|-------------|----------|--------------------|--------|--------------------------------------|-----|---------------------|-----|------------|---------|-------------|---------------|-----|
| Type Plasma Gas: Air    |     |            |             |          |                    |        | Type Secondary Gas: Single Gas Torch |     |                     |     |            |         |             |               |     |
| Thickness               |     | Tip        | Output      | Amperage | Speed (Per Minute) |        | Standoff                             |     | Plasma Gas Pressure |     | Flow (CFH) |         | Pierce      | Pierce Height |     |
| Inches                  | mm  | (Cat. No.) | Volts (VDC) | (Amps)   | Inches             | Meters | Inches                               | mm  | psi*                | bar | Plasma     | Total** | Delay (Sec) | Inches        | mm  |
| 0.06                    | 1.5 | 9-8209     | 112         | 50       | 265                | 6.73   | 0.13                                 | 3.2 | 75                  | 5.2 | 90         | 245     | 0           | 0.2           | 5.1 |
| 0.075                   | 1.9 | 9-8209     | 113         | 50       | 250                | 6.35   | 0.13                                 | 3.2 | 75                  | 5.2 | 90         | 245     | 0.1         | 0.2           | 5.1 |
| 0.12                    | 3   | 9-8209     | 120         | 50       | 175                | 4.45   | 0.13                                 | 3.2 | 75                  | 5.2 | 90         | 245     | 0.1         | 0.2           | 5.1 |
| 0.188                   | 3.4 | 9-8209     | 127         | 50       | 100                | 2.54   | 0.13                                 | 3.2 | 75                  | 5.2 | 90         | 245     | 0.2         | 0.2           | 5.1 |
| 0.25                    | 6.4 | 9-8209     | 134         | 50       | 54                 | 1.37   | 0.19                                 | 4.8 | 75                  | 5.2 | 90         | 245     | 0.3         | 0.2           | 5.1 |
| 0.375                   | 9.5 | 9-8209     | 142         | 50       | 28                 | 0.71   | 0.19                                 | 4.8 | 75                  | 5.2 | 90         | 245     | 0.5         | 0.2           | 5.1 |

This Page Intentionally Blank



SECTION 5 SYSTEM: SERVICE

5.01 General Maintenance



**Warning!**  
**Disconnect input power before maintaining.**

Maintain more often if used under severe conditions

Each Use

Visual check of torch tip and electrode

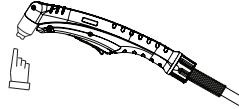

Weekly

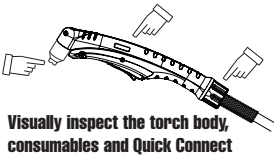

Visually inspect the cables and leads. Replace as needed

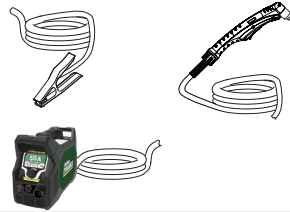

3 Months

Replace all broken parts



Clean exterior of power supply



5.02 Maintenance Schedule



**NOTE!**

The actual frequency of maintenance may need to be adjusted according to the operating environment.

**Daily Operational Checks or Every Six Cutting Hours:**

1. Check torch consumable parts, replace if damaged or worn.
2. Check plasma and secondary supply and pressure/flow.

**Weekly or Every 30 Cutting Hours:**

1. Check fan for proper operation and adequate air flow.
2. Inspect torch for any cracks or exposed wires, replace if necessary.
3. Inspect input power cable for damage or exposed wires, replace if necessary.

**Six Months or Every 720 Cutting Hours:**

1. Check cables and hoses for leaks or cracks, replace if necessary.

**CAUTION**

Do not blow air into the power supply during cleaning. Blowing air into the unit can cause metal particles to interfere with sensitive electrical components and cause damage to the unit.





**5.03 Common Faults**

| <b>Problem - Symptom</b>  | <b>Common Cause</b>   |
|---------------------------|---|
| Insufficient Penetration  | <ol style="list-style-type: none"> <li>1. Cutting speed too fast.</li> <li>2. Torch tilted too much.</li> <li>3. Metal too thick.</li> <li>4. Worn torch parts.</li> <li>5. Cutting current too low.</li> <li>6. Non - Genuine Thermal Dynamics parts used.</li> <li>7. Incorrect gas pressure. Line pressure 90-125 psi (6.2-8.6 bar / 620-862 kPa).</li> </ol>                    |
| Main Arc Extinguishes     | <ol style="list-style-type: none"> <li>1. Cutting speed too slow.</li> <li>2. Torch standoff too high from workpiece.</li> <li>3. Cutting current too high.</li> <li>4. Work cable disconnected.</li> <li>5. Worn torch parts.</li> <li>6. Non - Genuine Thermal Dynamics parts used.</li> <li>7. Line voltage drop due to extension cord or supply line being too long.</li> </ol> |
| Excessive Dross Formation | <ol style="list-style-type: none"> <li>1. Cutting speed too slow.</li> <li>2. Torch standoff too high from workpiece.</li> <li>3. Worn torch parts.</li> <li>4. Improper cutting current.</li> <li>5. Non - Genuine Thermal Dynamics parts used.</li> <li>6. Incorrect gas pressure.</li> </ol>   |
| Short Torch Parts Life    | <ol style="list-style-type: none"> <li>1. Oil or moisture in air source.</li> <li>2. Exceeding system capability (material too thick).</li> <li>3. Excessive pilot arc time.</li> <li>4. Gas pressure too low.</li> <li>5. Improperly assembled torch.</li> <li>6. Non - Genuine Thermal Dynamics parts used.</li> </ol>  |
| Difficult Starting        | <ol style="list-style-type: none"> <li>1. Worn torch parts.</li> <li>2. Non - Genuine Thermal Dynamics parts used.</li> <li>3. Incorrect gas pressure.</li> <li>4. Line voltage too low.</li> <li>5. Wrong parts for current selection.</li> <li>6. Hose restriction.</li> </ol>  |

## 5.04 Basic Troubleshooting Guide

**WARNING**

There are extremely dangerous voltage and power levels present inside this unit. Do not attempt to diagnose or repair unless you have had training in power electronics measurement and troubleshooting techniques.

| Problem - Symptom  | Possible Cause   | Recommended Action  |
|--|--|---|
| Main Switch is ON but the LCD does not light   | <ol style="list-style-type: none"> <li>1. Primary power disconnect is in OFF position.</li> <li>2. Primary fuses / breakers are blown or tripped.</li> <li>3. Faulty components in unit.</li> </ol>  | <ol style="list-style-type: none"> <li>1. Turn primary power disconnect switch to ON position.</li> <li>2. a) Have qualified person check primary fuses / breakers.<br/>b) Connect unit to known good primary power receptacle.</li> <li>3. Return to authorized service center for repair or replacement.</li> </ol>   |
| Overheating communication screen<br>                                | <ol style="list-style-type: none"> <li>1. Air flow through or around the unit is obstructed.</li> <li>2. Duty cycle of the unit has been exceeded.</li> <li>3. Failed components in unit.</li> </ol>   | <ol style="list-style-type: none"> <li>1. Allow unit to cool.</li> <li>2. Refer to clearance information – see Section "2.04 Power Supply Specifications ETL" on page 16.</li> <li>3. Return to authorized service center for repair or replacement.</li> </ol>   |
| Air pressure communication screen<br>                               | <ol style="list-style-type: none"> <li>1. Gas supply not connected to unit.</li> <li>2. Gas supply not turned <b>ON</b>.</li> <li>3. Gas supply pressure too low or too high.</li> <li>4. Failed components in unit.</li> </ol>  | <ol style="list-style-type: none"> <li>1. Connect gas supply to unit.</li> <li>2. Turn gas supply <b>ON</b>.</li> <li>3. Set air supply inlet pressure to unit to 120 psi / 8.27 bar / 827 kPa.</li> <li>4. Return to authorized service center for repair or replacement.</li> </ol>   |
| Torch installation or cover assembly communication screen (PIP)<br> | <ol style="list-style-type: none"> <li>1. Shield Cup loose.</li> <li>2. Torch not properly connected to power supply.</li> <li>3. Problem in torch and leads PIP circuit.</li> <li>4. Failed components in unit.</li> </ol>  | <ol style="list-style-type: none"> <li>1. Hand tighten the shield cup until it is snug.</li> <li>2. Insure torch ATC is securely fastened to unit.</li> <li>3. Replace torch and leads or return to authorized service center for repair or replacement.</li> <li>4. Return to authorized service center for repair or replacement.</li> </ol>  |
| Electrode or tip installation communication screen (PIC)<br>      | <ol style="list-style-type: none"> <li>1. Torch shield cup is loose.</li> <li>2. Torch tip, electrode or start cartridge missing.</li> <li>3. Torch start cartridge is stuck.</li> <li>4. Unit inlet gas pressure is too high causing continuous gas flow.</li> <li>5. Open conductor in torch leads.</li> <li>6. Problem in the torch and leads switch circuit.</li> <li>7. Failed components in unit.</li> </ol> | <ol style="list-style-type: none"> <li>1. Tighten shield cup by hand. Do not overtighten.</li> <li>2. Turn OFF power supply. Remove shield cup. Install missing parts.</li> <li>3. Turn OFF power supply. Bleed down system pressure. Remove shield cup, tip and start cartridge. Check start cartridge lower end fitting for free movement. Replace if fitting does not move freely.</li> <li>4. Decrease gas supply pressure to 125 psi / 8.62 bar / 862 kPa or less.</li> <li>5. Replace torch and leads or return to authorized service center for repair or replacement.</li> <li>6. Replace torch and leads or return to authorized service center for repair or replacement.</li> <li>7. Return to authorized service center for repair or replacement.</li> </ol> |
| Start error communication screen<br>                              | <ol style="list-style-type: none"> <li>1. Start signal is active when ON/OFF SWITCH is turned to ON position.</li> <li>2. Problem in the torch and leads switch circuit.</li> <li>3. Failed components in unit.</li> </ol>   | <ol style="list-style-type: none"> <li>1. Start can be active for one of the following: <ul style="list-style-type: none"> <li>• Hand torch switch held closed</li> <li>• CNC START signal is active low</li> </ul> </li> <li>2. Replace torch and leads or return to authorized service center for repair or replacement.</li> <li>3. Return to authorized service center for repair or replacement.</li> </ol>  |

| Problem - Symptom   | Possible Cause  | Recommended Action   |
|---|---|--|
| Input voltage communication screen<br> | 1. Primary input voltage problem. The input voltage is under 100VAC.<br>2. Failed components in unit.   | 1. Have qualified person check primary voltage to insure it meets unit requirements see Section "2.05 Input Wiring Specifications".<br>2. Return to authorized service center for repair or replacement.   |
| Nothing happens when torch switch or remote switch is closed (or CNC START signal is active). No gas flow               | 1. Problem in the torch and leads switch circuit (Remote pendant switch circuit).<br>2. CNC Controller device not providing Start signal.<br>3. Failed components in unit.  | 1. Take Torch and Leads (Remote Pendant) to Authorized Repair Facility.<br>2. Contact Controller manufacturer.<br>3. Return to authorized service center for repair or replacement.  |
| No Fault screen, no arc in torch  | 1. Failed components in unit.   | 1. Return to an authorized service center for repair.  |
| Pilot arc in ON but cutting arc will not establish  | 1. Work cable not connected to work piece.<br>2. Work cable/connector broken.<br>3. Failed components in unit.  | 1. Connect work cable.<br>2. Replace work cable.<br>3. Return to an authorized service center for repair.  |
| Torch cutting is diminished   | 1. Incorrect current setting.<br>2. Worn torch consumables.<br>3. Poor work cable connection to work piece.<br>4. Torch being moved too fast.<br>5. Excessive oil or water in torch.<br>6. Failed components in unit. | 1. Check and adjust to proper setting.<br>2. Check torch consumables and replace as needed.<br>3. Check the connection of the Work Lead to the work piece.<br>4. Reduce cutting speed.<br>5. Refer to "Check air quality" in Section 3 Torch.<br>6. Return to an authorized service center for repair. |

## 5.05 Power Supply Basic Parts Replacement

### Optional Single-Stage Filter Element Replacement

These instructions apply to power supplies where the optional Single-Stage Filter has been installed.

The Power Supply shuts down automatically when the Filter Element becomes completely saturated. The Filter Element can be removed from its housing, dried, and reused. Allow 24 hours for Element to dry. Refer to Section 6, Parts List, for replacement filter element catalog number.

1. Remove power from power supply.
2. Shut OFF air supply and bleed down system before disassembling Filter to change Filter Element.
3. Disconnect gas supply hose.
4. Turn the Filter Housing Cover counter-clockwise and remove it. The Filter Element is located inside the Housing.

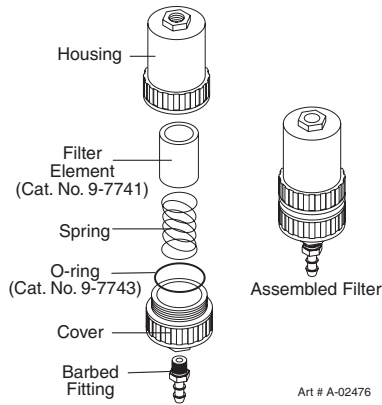

### *Optional Single-Stage Filter Element Replacement*

5. Remove the Filter Element from the Housing and set Element aside to dry.
6. Wipe inside of housing clean, then insert the replacement Filter Element open side first.
7. Replace Housing on Cover.
8. Reattach gas supply. Check for leaks.



#### **NOTE!**

If unit leaks between housing and cover, inspect the O-ring for cuts or other damage.

This completes the parts replacement procedures.

This Page Intentionally Blank

**SECTION 5 TORCH: SERVICE**

**5T.01 General Maintenance**



**NOTE!**

Refer to Previous "Section 5: System" for common and fault indicator descriptions.

**Cleaning Torch**

Even if precautions are taken to use only clean air with a torch, eventually the inside of the torch becomes coated with residue. This buildup can affect the pilot arc initiation and the overall cut quality of the torch.



**WARNING**

Disconnect primary power to the system before disassembling the torch or torch leads. DO NOT touch any internal torch parts while the AC indicator light of the Power Supply is ON.

The inside of the torch should be cleaned with electrical contact cleaner using a cotton swab or soft wet rag. In severe cases, the torch can be removed from the leads and cleaned more thoroughly by pouring electrical contact cleaner into the torch and blowing it through with compressed air.



**CAUTION**

Dry the torch thoroughly before reinstalling.

**O-Ring Lubrication**

An O-Ring on the Torch Head and ATC Male Connector requires lubrication on a scheduled basis. This will allow the O-Rings to remain pliable and provide a proper seal. The O-Rings will dry out, becoming hard and cracked if the lubricant is not used on a regular basis. This can lead to potential performance problems.

It is recommended to apply a very light film of O-Ring lubricant (Catalog # 8-4025) to the O-Rings on a weekly basis.

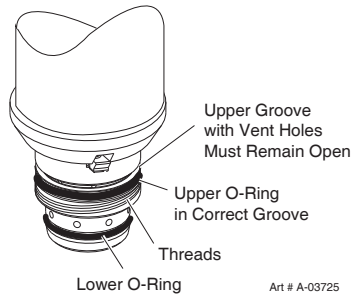

*Torch Head O-Ring*

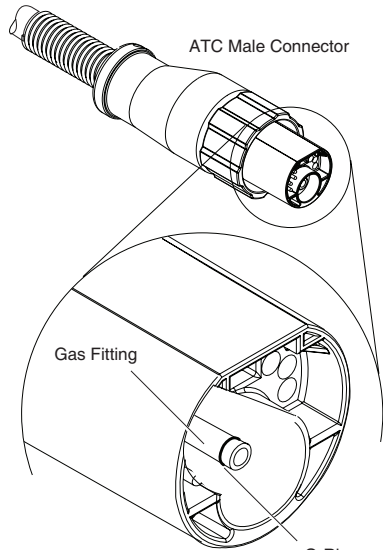

*ATC O-Ring*



**NOTE!**

DO NOT use other lubricants or grease, they may not be designed to operate within high temperatures or may contain "unknown elements" that may react with the atmosphere. This reaction can leave contaminants inside the torch. Either of these conditions can lead to inconsistent performance or poor parts life.

## 5T.02 Inspection and Replacement of Consumable Torch Parts



### WARNING

Disconnect primary power to the system before disassembling the torch or torch leads. DO NOT touch any internal torch parts while the AC indicator light of the Power Supply is ON.

Remove the consumable torch parts as follows:



### NOTE!

The shield cup holds the tip and start cartridge in place. Position the torch with the shield cup facing upward to prevent these parts from falling out when the cup is removed.

1. Unscrew and remove the shield cup from the torch.



### NOTE!

Slag built up on the shield cup that cannot be removed may effect the performance of the system.

2. Inspect the cup for damage. Wipe it clean or replace if damaged.

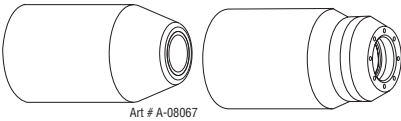

*Shield Cups*

3. On torches with a shield cup body and a shield cap or deflector, ensure that the cap or deflector is threaded snugly against the shield cup body. In shielded drag cutting operations (only), there may be an O-Ring between the shield cup body and drag shield cap. Do not lubricate the O-Ring.

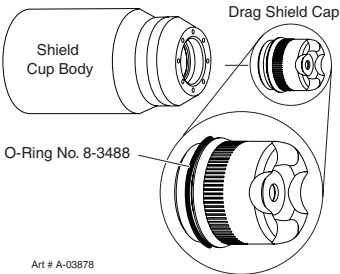

4. Remove the tip. Check for excessive wear (indicated by an elongated or oversized orifice). Clean or replace the tip if necessary.

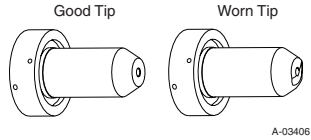

*Example of Tip Wear*

5. Remove the start cartridge. Check for excessive wear, plugged gas holes, or discoloration. Check the lower end fitting for free motion. Replace if necessary.

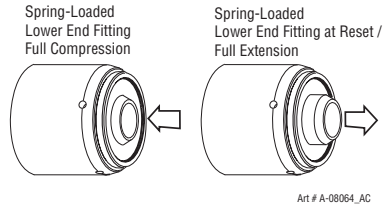

6. Pull the Electrode straight out of the Torch Head. Check the face of the electrode for excessive wear. Refer to the following figure.

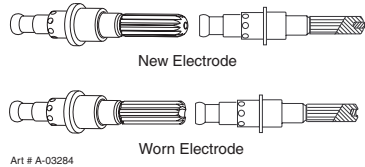

*Electrode Wear*

7. Reinstall the Electrode by pushing it straight into the torch head until it clicks.
8. Reinstall the desired start cartridge and tip into the torch head.
9. Hand tighten the shield cup until it is seated on the torch head. If resistance is felt when installing the cup, check the threads before proceeding.

This completes the parts replacement procedures.



## SECTION 6: PARTS LISTS

**6.01 Introduction****A. Parts List Breakdown**

The parts list provide a breakdown of all replaceable components. The parts lists are arranged as follows:

- 6.03 Power Supply Replacement
- 6.04 Replacement Parts
- 6.12 Options and Accessories
- 6.13 Replacement Parts for SL60 Hand Torch
- 6.14 Torch Consumable Parts (SL60)

**NOTE!**

Parts listed without item numbers are not shown, but may be ordered by the catalog number shown.

**B. Returns**

If a product must be returned for service, contact your distributor. Materials returned without proper authorization will not be accepted.

**6.02 Ordering Information**

Order replacement parts by catalog number and complete description of the part or assembly, as listed in the parts list for each type item. Also include the model and serial number of the power supply. Address all inquiries to your authorized distributor.

**6.03 Power Supply Replacement**

The following items are included with the replacement power supply: work cable & clamp, input power cable, gas pressure regulator / filter, SL60 Torch, spare parts kit, and operating manual.

| <b>Qty</b> | <b>Description</b>   | <b>Catalog #</b> |
|------------|--|------------------|
| 1          | CUTMASTER 50+ Plasma cutting machine package<br>Thermal Dynamics ETL | 1-5000-1         |

| Item # | Qty | Description                        | Catalog #  |
|--------|-----|------------------------------------|------------|
| 1      | 1   | Top Handle Kit                     | 0700401193 |
| 2      | 1   | Handle Cover                       | 0700401194 |
| 3      | 1   | Panel RH CM50+ TD_AEB              | 0700402255 |
| 4      | 1   | Assembly Panel Front CM50+/70+     | 0700402259 |
| 5      | 1   | Panel LH CM50 TD_AEB               | 0700402260 |
| 6      | 1   | Assembly Panel Rear CM50+ TD_AEB   | 0700401403 |
| 7      | 1   | Top Panel                          | 0700401195 |
| 8      | 1   | Plastic Base Plate                 | 0700402285 |
| 9      | 16  | Screw, black, full thread, M5X12   | 0700400995 |
| 10     | 12  | Screw, black, self-tapping, 4.8X16 | 0700400996 |

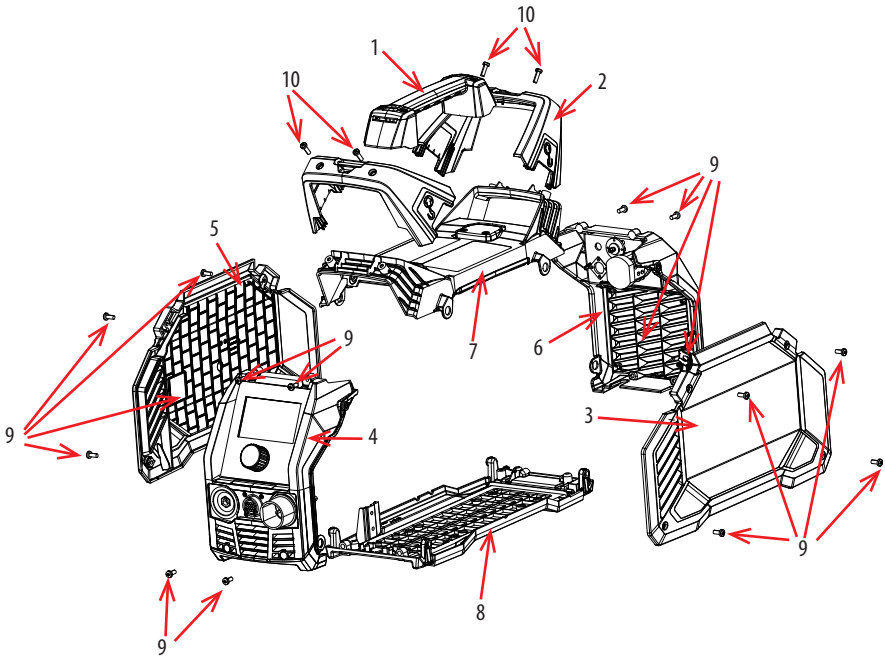

## 6.05 Front Panel Replacement Part

| Item # | Qty | Description                           | Catalog #  |
|--------|-----|---------------------------------------|------------|
| 1      | 1   | Assembly PCB Display CM50+ 1PH TD_AEB | 0700402304 |
| 2      | 1   | Control Knob                          | 0700402281 |
| 3      | 1   | OKC 10-25 with screw/washer/nut       | 0700402327 |
| 4      | 1   | Torch connection with cable           | 0700402328 |
| 5      | 1   | CNC connection kit                    | 0700402329 |
| 6      | 2   | Y capacitor with terminal             | 0700402330 |

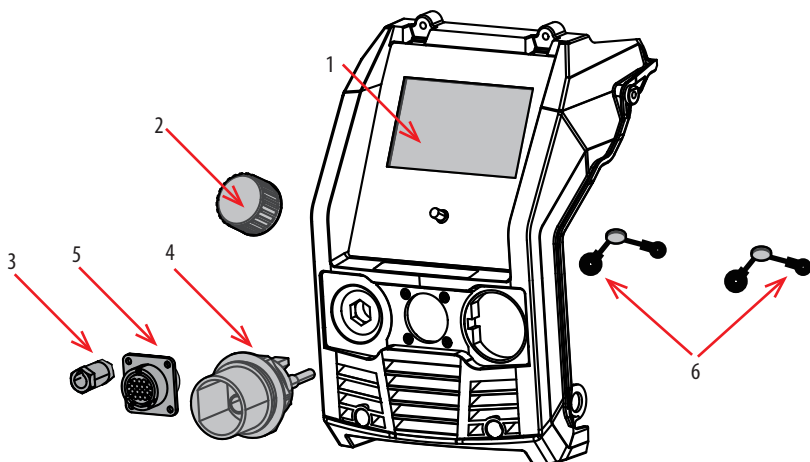

## 6.06 Rear Panel Replacement Part

| Item # | Qty | Description   | Catalog #  |
|--------|-----|---|------------|
| 1      | 1   | Power Switch, LW26-25 4AB-04J/2 690V, CM50+ 1PH     | 0700401191 |
| 2      | 1   | Air Fitting Type 1/4" NPT Milton type D(USA)        | 0700400917 |
| 3      | 1   | Air Fitting adapter with the clamp and hose(EU USA) | 0700402334 |
| 4      | 1   | Input Cable ETL,3x10 AWG,3M (not shown),CM50+ 1PH   | 0700401406 |

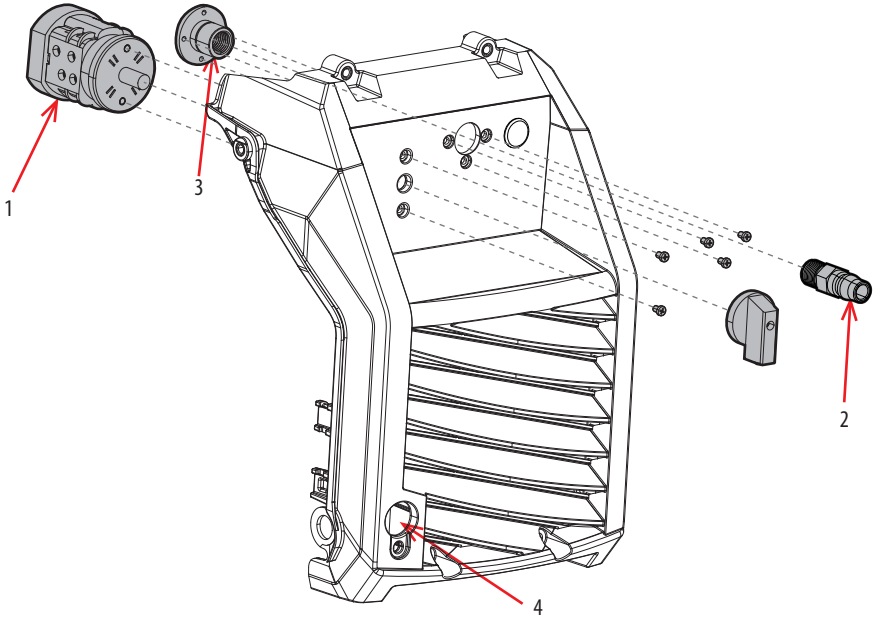

6.07 Top Side Replacement Parts

| Item # | Qty | Description                         | Catalog #  |
|--------|-----|-------------------------------------|------------|
| 1      | 1   | Control PCB Assembly, CM50+ 1PH     | 0700402322 |
| 2      | 1   | Switching Mode Power Supply PCB 1PH | 0700402031 |
| 3      | 1   | Capacitor PCBA, CM50+ 1PH           | 0700402005 |
| 4      | 1   | Intermediate board, CM50+ 70+1PH    | 0700402033 |

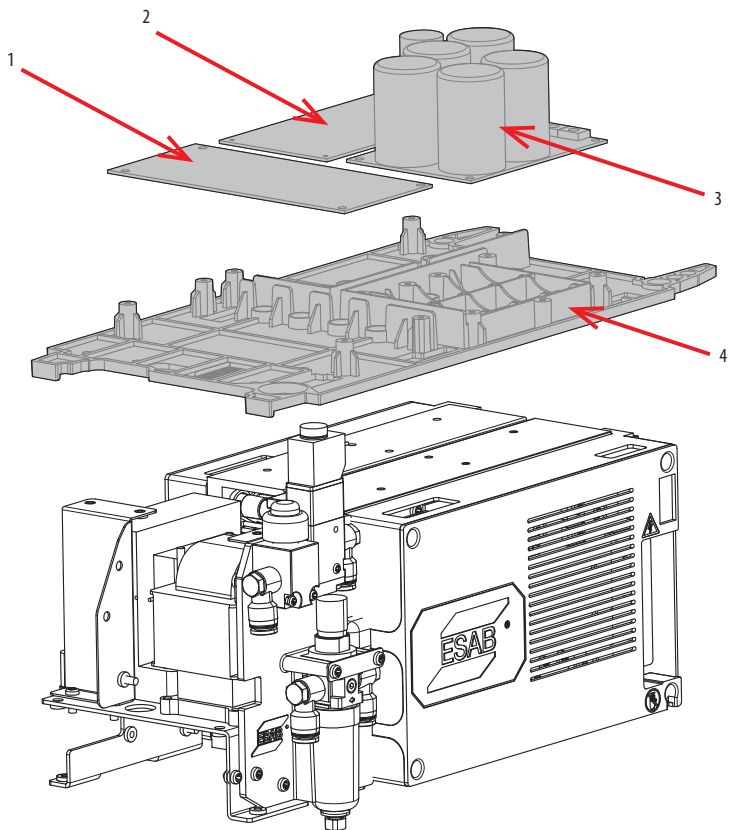

## 6.08 Bottom Side Replacement Parts

| Item # | Qty | Description     | Catalog #  |
|--------|-----|-----------------|------------|
| 1      | 1   | Plastic Support | 0700402284 |

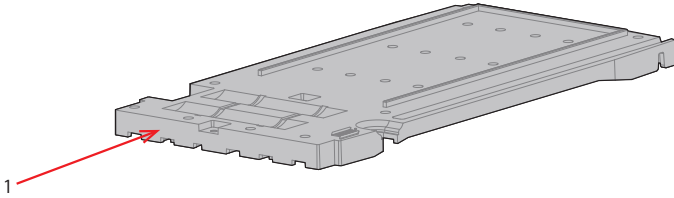
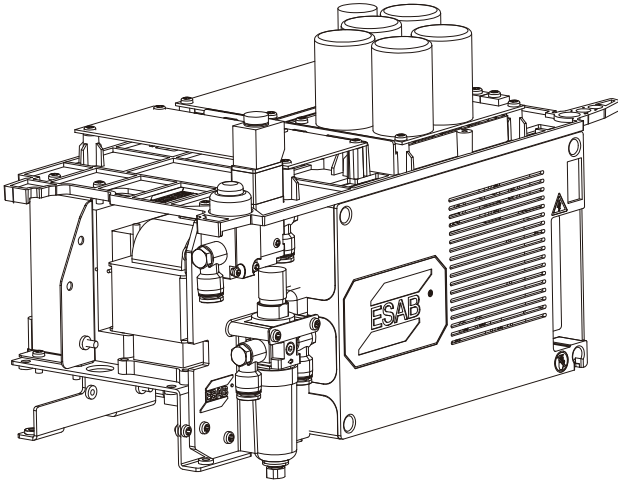

6.09 Middle Side Replacement Parts

| Item # | Qty | Description   | Catalog #  |
|--------|-----|---|------------|
| 1      | 1   | Pressure Sensor, XGZP6161D102V  | 0700402270 |
| 2      | 1   | Solenoid Assembly, Valve block V3211-06E4                                 | 0700402271 |
| 3      | 1   | Inbuilt Air Regulator Assembly, AW1000-M8, hose ID 8mm                    | 0700402276 |
| 4      | 1   | Main Transformer ETL,CM50+ 1PH<br>(Incl.Thermocouple,Current transformer) | 0700402009 |
| 5      | 1   | Reactor   | 0700402278 |
| 6      | 1   | PFC Inductor  | 0700402011 |
| 7      | 1   | Inbuilt Air Regulator holder  | 0700402034 |
| 8      | 1   | PFC Inductor baseplate, CM50+ 70+ 1PH                                     | 0700402035 |

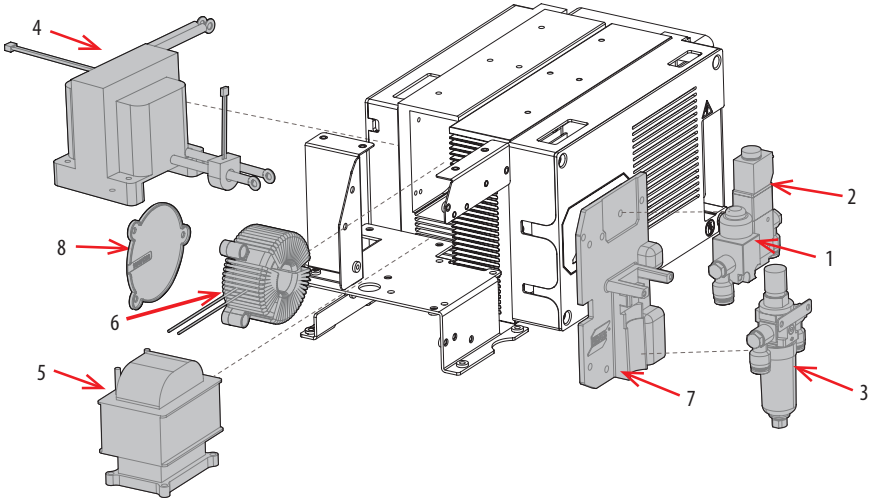

## 6.10 Left Side Replacement Parts

| Item # | Qty | Description          | Catalog #  |
|--------|-----|----------------------|------------|
| 1      | 1   | Mur Plastic Cover    | 0700402282 |
| 2      | 1   | Mur PCB Assembly 1PH | 0700402012 |
| 3      | 2   | Diode module         | 0700402013 |

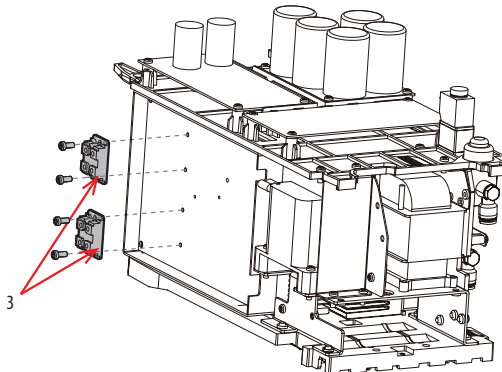
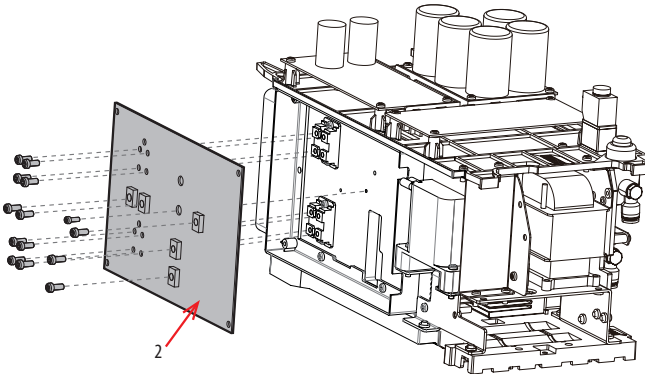
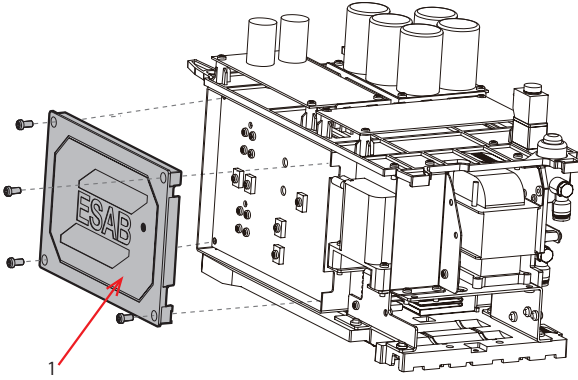



6.11 Right Side Replacement Parts

| Item # | Qty | Description   | Catalog #  |
|--------|-----|---|------------|
| 1      | 1   | Fan, 0.61A, RUNDA   | 0700400941 |
| 2      | 1   | IGBT Plastic Cover  | 0700402283 |
| 3      | 1   | PFC PCB Assembly,ETL,CM50+/70+<br>1PH (Incl. IGBT, Rectifier) | 0700402017 |
| 4      | 1   | IGBT PCB Assembly, ETL, CM50+ 1PH (Incl. IGBT)                | 0700402014 |
| 5      | 2   | Copper strip  | 0700402025 |
| 6      | 1   | PFC Thermocouple  | 0700402016 |
| 7      | 1   | PFC FRD   | 0700402018 |

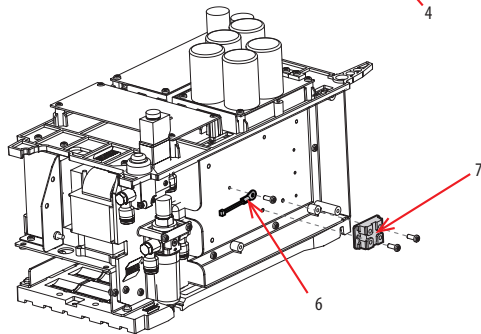
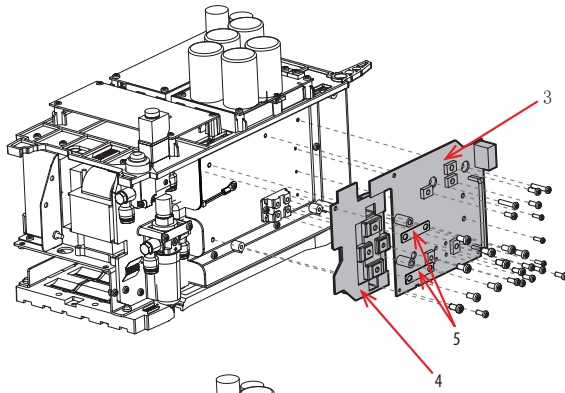
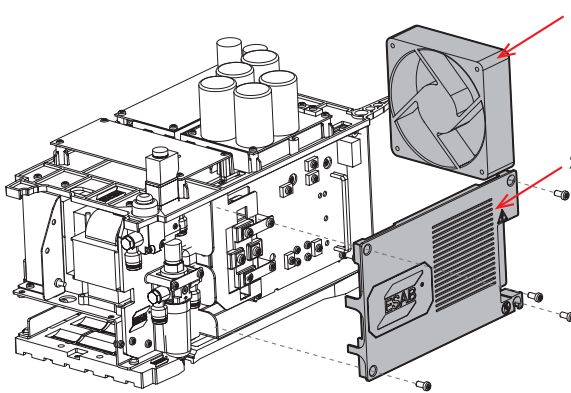

## 6.12 Cable and Wiring Harness Replacement Parts

| Item # | Qty | Description  | Catalog #  |
|--------|-----|--|------------|
| 1      | 1   | Cable, Mains Switch, 2×10AWG, CM50+ 1PH, Blue      | 0700402019 |
| 2      | 1   | Cable, DC Bus IN, 2×10AWG, CM50+1PH, Red & Black   | 0700402021 |
| 3      | 1   | Cable, DC Bus OUT, 2×10AWG, CM50+ 1PH, Red & Black | 0700402023 |
| 4      | 1   | Wiring, Internal PE cable, 10AWG, CM50+ 1PH        | 0700402026 |
| 5      | 1   | Cable, Bias Power inverter                         | 0700402028 |
| 6      | 1   | Cable, Bias Power main control-01                  | 0700402291 |
| 7      | 1   | Cable, Bias Power main control-02                  | 0700402307 |
| 8      | 1   | Cable, Bias Power rectifier                        | 0700402308 |
| 9      | 1   | Cable, Bias Power input                            | 0700402029 |
| 10     | 1   | Wiring Harness, inverter driver                    | 0700402309 |
| 11     | 1   | Wiring Harness, inverter signal                    | 0700402030 |
| 12     | 1   | Wiring Harness, rectifier signal                   | 0700402310 |
| 13     | 1   | Cable, display signal                              | 0700402311 |
| 14     | 1   | Cable, Output Feedback                             | 0700402312 |
| 15     | 1   | Cable, Negative output                             | 0700402313 |
| 16     | 1   | Cable, Positive output                             | 0700402314 |



### NOTE!

Cable and Wiring Harness's position refer to APPENDIX 5: SYSTEM SCHEMATIC CE & ETL on page 81.

## 6.13 Options and Accessories

| Qty | Description  | Catalog #  |
|-----|--|------------|
| 1   | Single - Stage Filter Kit (includes Filter & Hose) | 7-7507     |
| 1   | Replacement Filter Body                            | 9-7740     |
| 1   | Replacement Filter Hose (not shown)                | 9-7742     |
| 2   | Replacement Filter Element                         | 9-7741     |
| 1   | Work Cable #8 with 50mm OKC plug                   | 9-9692     |
| 1   | Multi - Purpose Cart                               | 7-8888     |
| 1   | Shoulder strap kit                                 | 0445197880 |

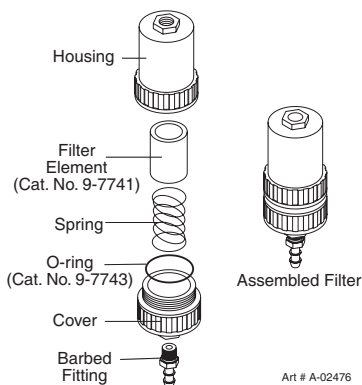

Art # A-02476

### Optional Single - Stage Filter Kit

PARTS LIST

6.14 Replacement Parts for SL60 Hand Torch

| Item # | Qty | Description   | Catalog # |
|--------|-----|---|-----------|
| 1      | 1   | Torch Handle Replacement Kit (includes items No. 2 & 3)           | 9-7030    |
| 2      | 1   | Trigger Assembly Replacement Kit                                  | 9-7034    |
| 3      | 1   | Handle Screw Kit (5 each, 6-32 x 1/2" cap screw, and wrench)      | 9-8062    |
| 4      | 1   | Torch Head Assembly Replacement Kit (includes items No. 5 & 6)    | 9-8219    |
| 5      | 1   | Large O-Ring  | 8-3487    |
| 6      | 1   | Small O-Ring  | 8-3486    |
| 7      |     | Leads Assemblies with ATC connectors (includes switch assemblies) |           |
|        | 1   | SL60, 20 - foot / 6.1m Leads Assembly with ATC connector          | 4-7834    |
|        | 1   | SL60, 50 - foot / 15.2m Leads Assembly with ATC connector         | 4-7835    |
| 8      | 1   | Switch Kit  | 9-7031    |
| 9      | 1   | Complete SL60 20'/6.1m torch assembly (not shown)                 | 7-5200    |

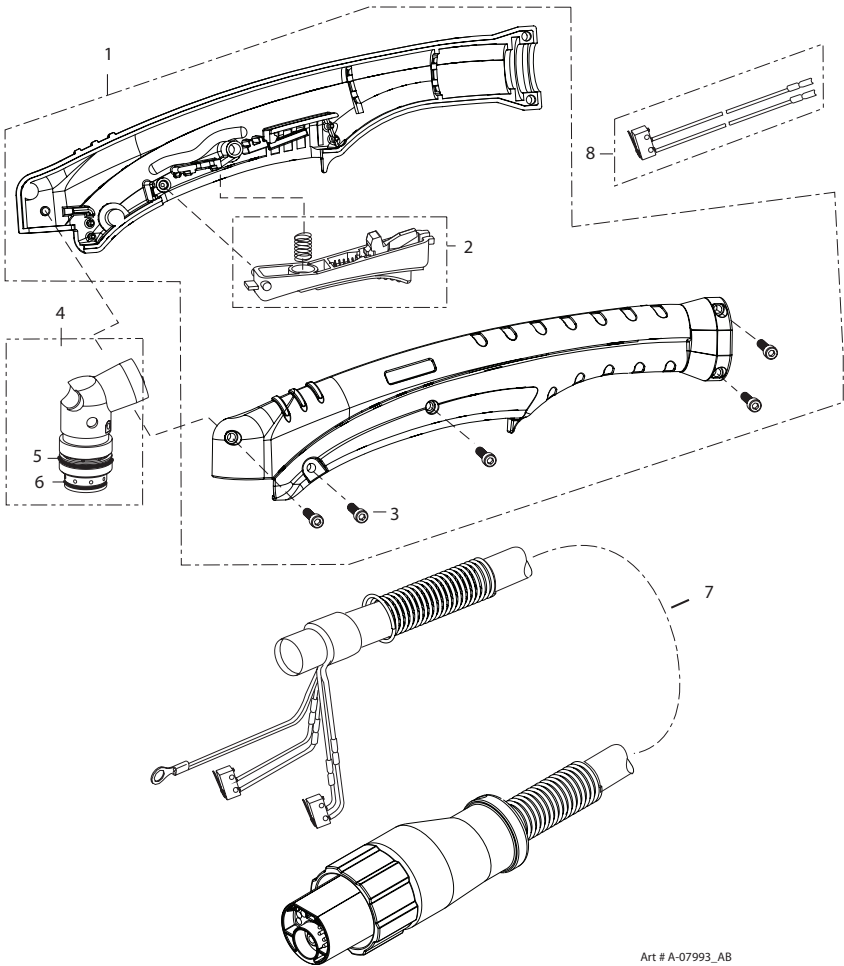

Art # A-07993\_AB

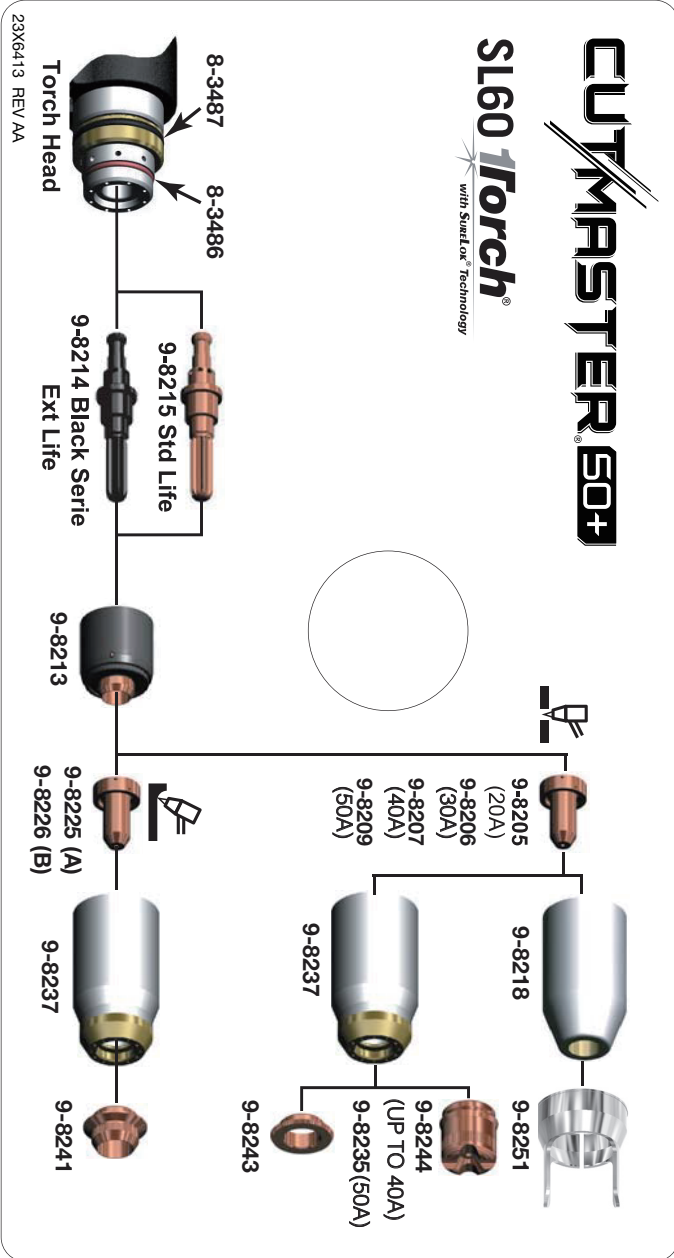

6.16 Torch Consumable Parts Manual (SL60) Torch

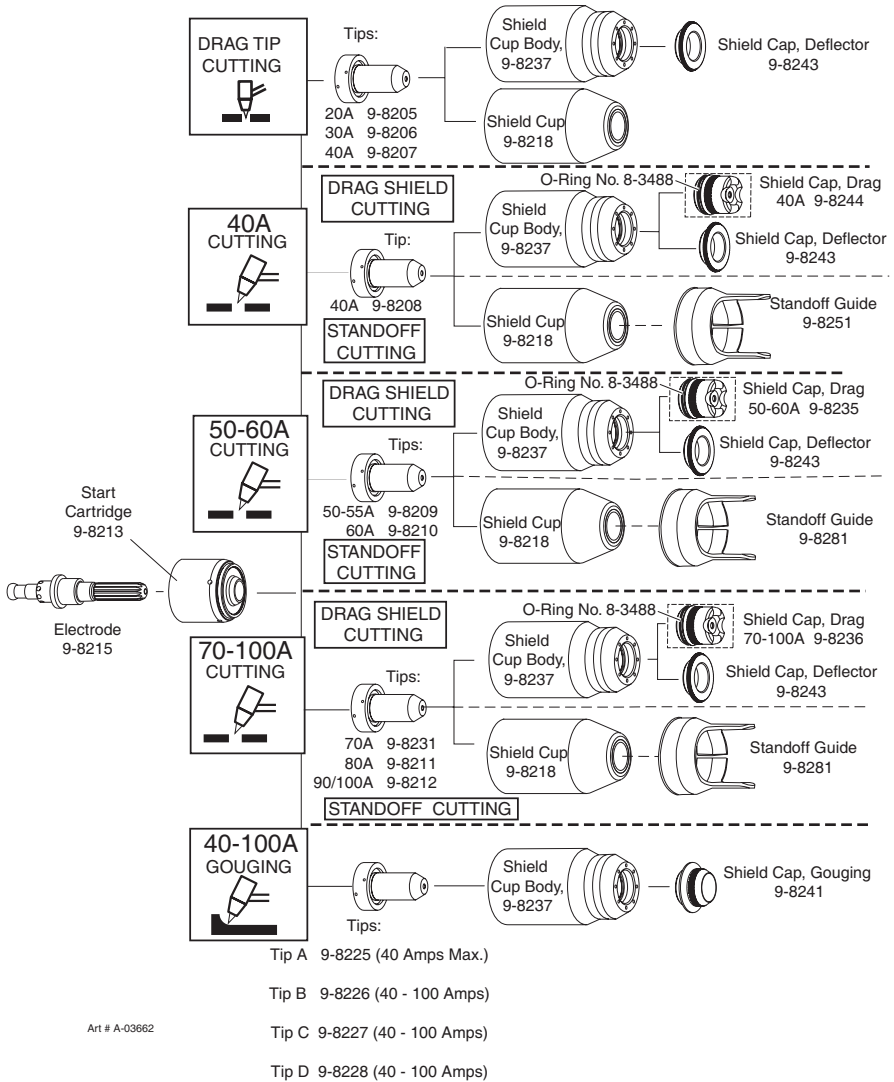

**6.17 Replacement Parts - for SL100 Mechanized Torches with Unshielded Leads**

| <b>Item #</b> | <b>Qty</b> | <b>Description</b>  | <b>Catalog #</b> |
|---------------|------------|---|------------------|
| 1             | 1          | Torch Head Assembly without leads (includes items 2, 3, and 14) | 9-8220           |
| 2             | 1          | Large O-ring  | 8-3487           |
| 3             | 1          | Small O-ring  | 8-3486           |
| 4             | 1          | PIP Switch Kit  | 9-7036           |
| 5             |            | Unshielded Automated Leads Assemblies with ATC connectors       |                  |
|               | 1          | 5 - foot / 1.5 m Leads Assembly with ATC connector              | 4-7850           |
|               | 1          | 10 - foot / 3.05 m Leads Assembly with ATC connector            | 4-7851           |
|               | 1          | 25 - foot / 7.6 m Leads Assembly with ATC connector             | 4-7852           |
|               | 1          | 50 - foot / 15.2 m Leads Assembly with ATC connector            | 4-7853           |
| 6             |            | Unshielded Mechanized Leads Assemblies with ATC connectors      |                  |
|               | 1          | 5 - foot / 1.5 m Leads Assembly with ATC connector              | 4-7842           |
|               | 1          | 10 - foot / 3.05 m Leads Assembly with ATC connector            | 4-7843           |
|               | 1          | 25 - foot / 7.6 m Leads Assembly with ATC connector             | 4-7844           |
|               | 1          | 50 - foot / 15.2 m Leads Assembly with ATC connector            | 4-7845           |
| 7             | 1          | 11" / 279 mm Rack   | 9-7041           |
| 8             | 1          | 11" / 279 mm Mounting Tube                                      | 9-7043           |
| 9             | 1          | End Cap Assembly  | 9-7044           |
| 10            | 2          | Body, Mounting, Pinch Block                                     | 9-4513           |
| 11            | 1          | Pin, Mounting, Pinch Block                                      | 9-4521           |
| 12            | 1          | Torch Holder Sleeve   | 7-2896           |
| 13            | 1          | PIP Plunger and Return Spring Kit                               | 9-7045           |
|               | 1          | Pinion Assembly (Not shown)                                     | 7-2827           |
|               | 1          | 5" / 126 mm Positioning Tube (Not shown)                        | 9-7042           |



**NOTE!**

\* Does not include Control Cable Adapter or Through - Hole Protector.

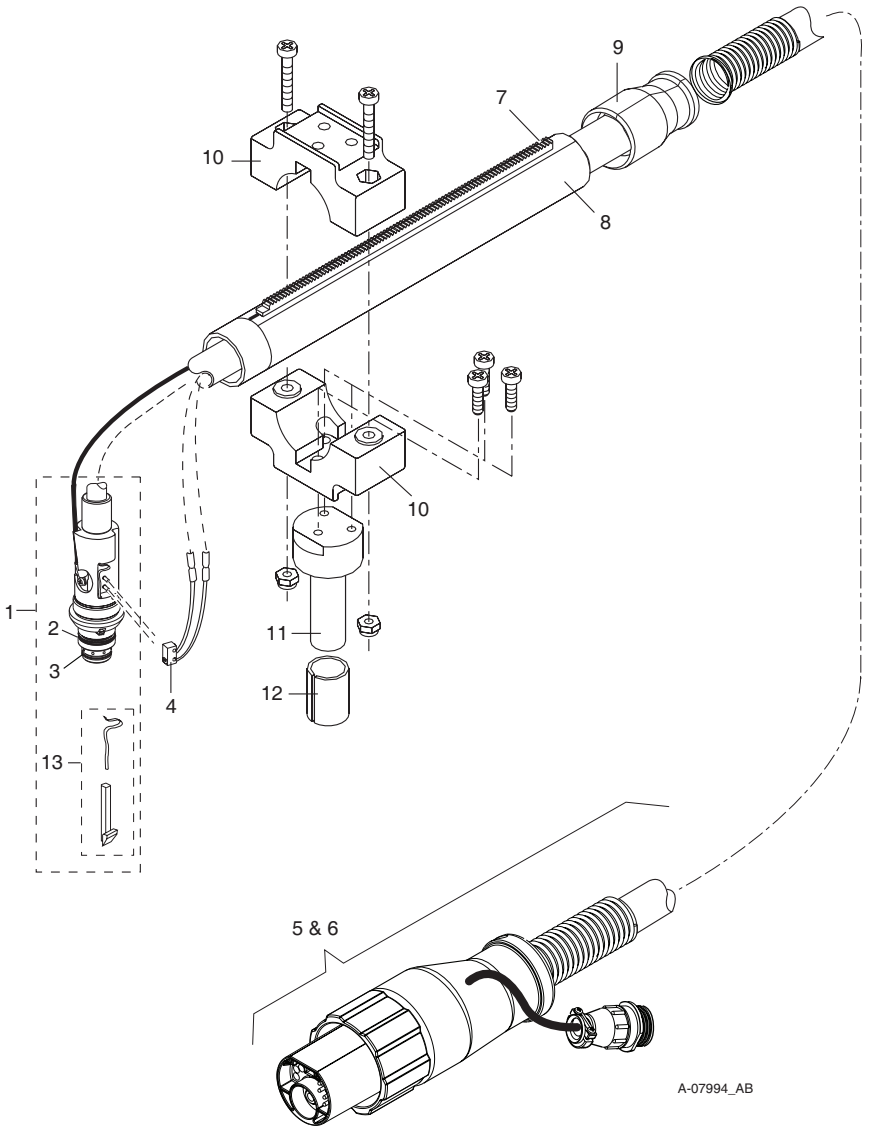

A-07994\_AB

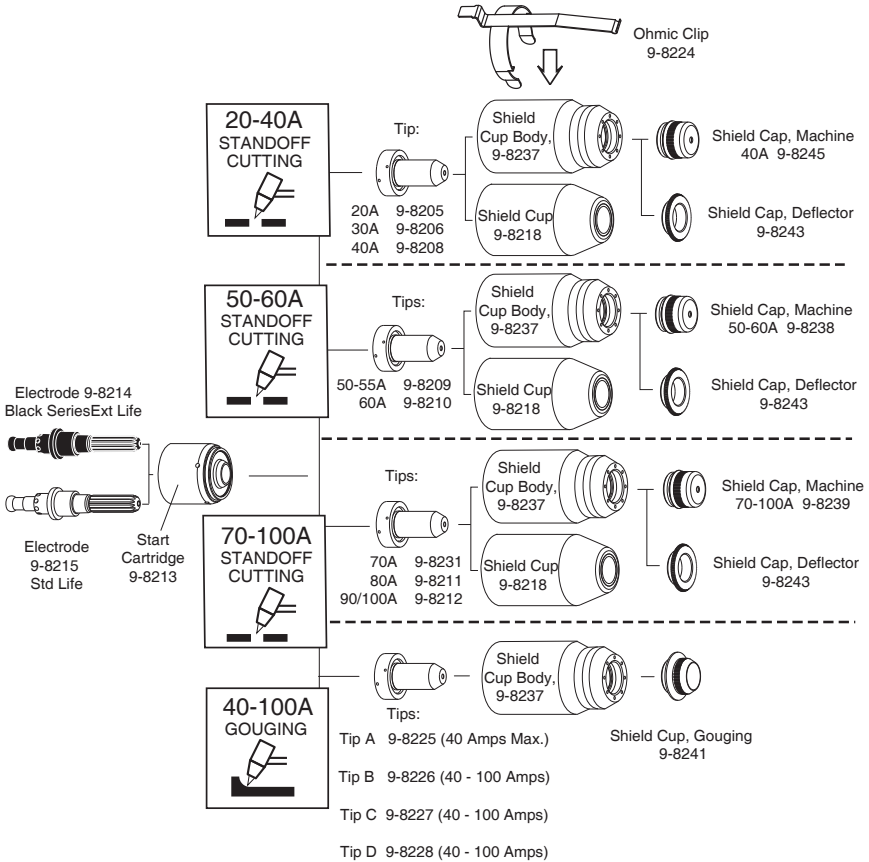



APPENDIX 1: DATA TAG INFORMATION

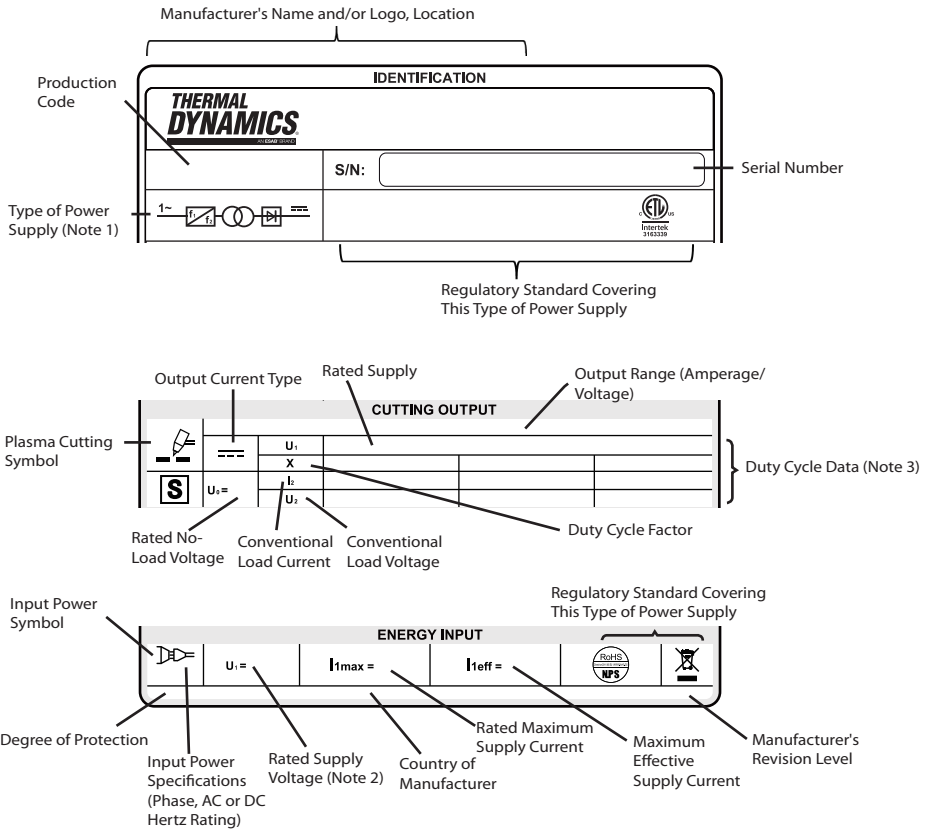

NOTES:

1. Symbol shown indicates single- or three-phase AC input, static frequency converter-transformer-rectifier, DC output.
2. Indicates input voltages for this power supply. Most power supplies carry a label on the bottom of the unit showing input voltage requirements for the power supply as built.
3. Top row: Duty cycle values.  
Duty cycle values meet or exceed the IEC specified rating.  
Second row: Rated cutting current values.  
Third row: Conventional load voltage values.
4. Sections of the Data Tag may be applied to separate areas of the power supply.

Standard Symbols

|  |       |
|--|-------|
|  | AC    |
|  | DC    |
|  | Phase |

A. Hand Torch Pin - Out Diagram

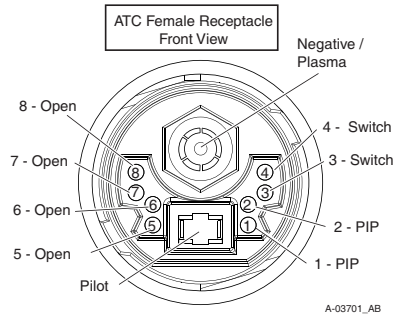
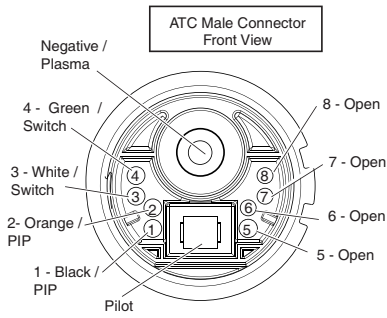

**APPENDIX 3: TORCH CONNECTION DIAGRAMS**

**A. Hand Torch Connection Diagram**

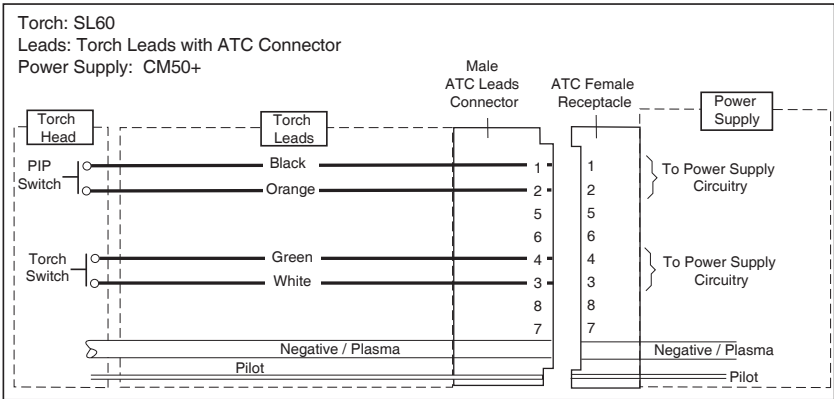

APPENDIX 4: RAW ARC VOLTAGE

If raw arc voltage is necessary for the torch height control, the customer must supply an 18 AWG (1.0mm<sup>2</sup>), single pair, unshielded cable rated for 400V or greater. All work must be performed following applicable local and national codes.

1. Disconnect the power from the power supply.
2. Remove the left and right panel, and then remove the top cover.
3. Remove the hole plug located on the rear panel, and route the cable through the hole.

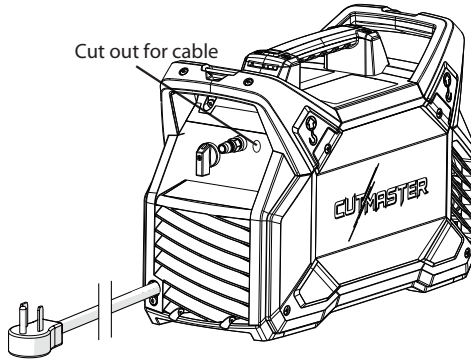

4. Connect to CN12 on the main control board: - (negative) polarity and + (positive) polarity.

RAW ARC VOLTAGE  
PCB Screw Terminal

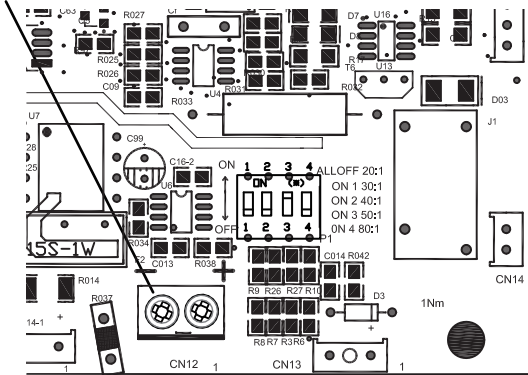



**WARNING**  
The raw arc voltage can exceed 350VDC!!!!

5. Tighten the PCB screw terminal.
6. Assemble the top cover and side panels.
7. Connect the cable to the negative and positive polarities of Torch Height Control.

APPENDIX 5: SYSTEM SCHEMATIC

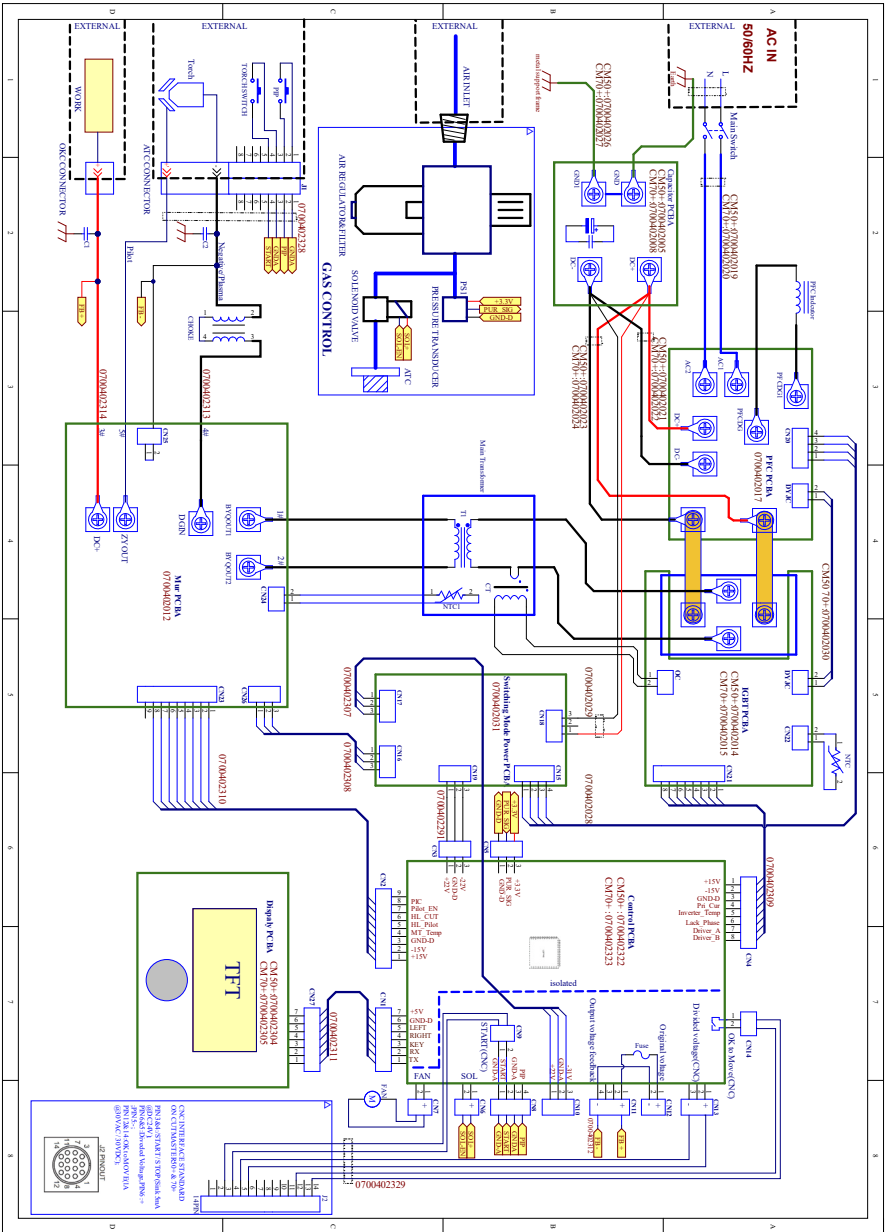



ESAB / [esab.com](http://esab.com)

