

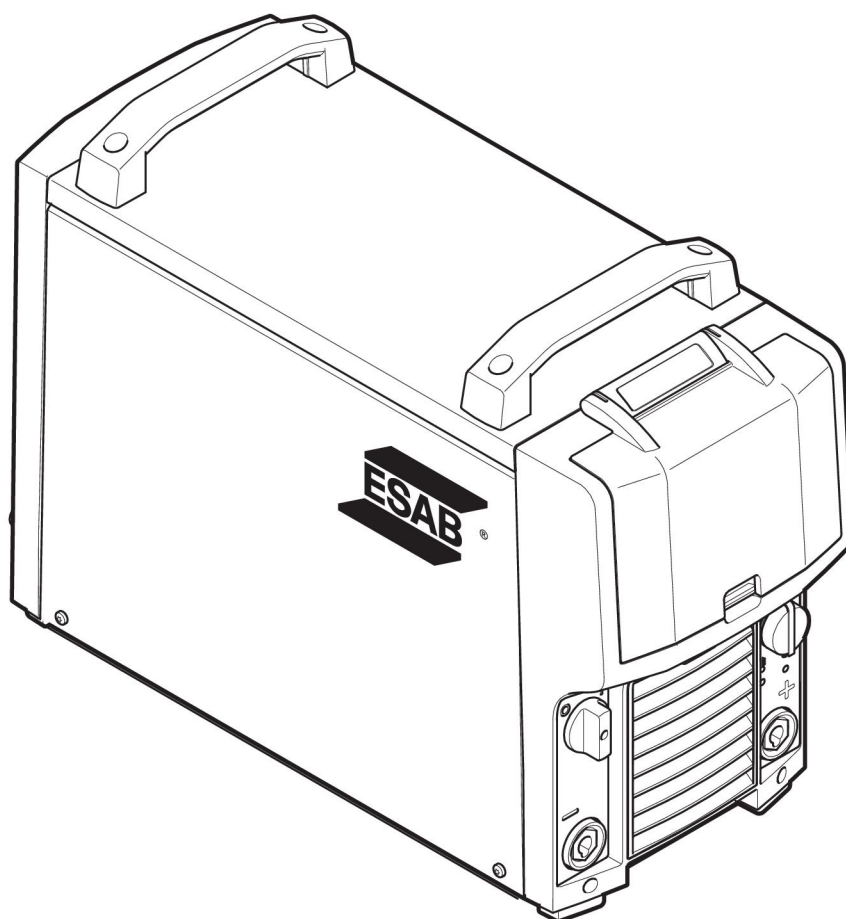

Aristo®

Mig 4004i Pulse

380-460 V



Instruction manual



EU DECLARATION OF CONFORMITY

According to:

The Low Voltage Directive 2014/35/EU;
The RoHS Directive 2011/65/EU;

The EMC Directive 2014/30/EU;
The Ecodesign Directive 2009/125/EC

Type of equipment

Arc welding power source

Type designation

MIG 4004i Pulse, 400V
MIG 4004i Pulse, 415V

with serial number from 551 xxx xxxx (2015 w51)
with serial number from 704 xxx xxxx (2017 w4)

Brand name or trademark

ESAB

Manufacturer or his authorised representative established within the EEA

ESAB AB
Lindholmsallén 9, Box 8004, SE-402 77 Göteborg, Sweden
Phone: +46 31 50 90 00, www.esab.com

The following EN standards and regulations in force within the EEA has been used in the design:

EN IEC 60974-1:2018/A1:2019	Arc welding equipment - Part 1: Welding power sources
EN 60974-10:2014/A1:2015,	Arc welding equipment - Part 10: Electromagnetic compatibility (EMC) requirements
EU no. 2019/1784	Ecodesign requirements for welding equipment pursuant to Directive 2009/125/EC

Additional Information:

Restrictive use, Class A equipment, intended for use in locations other than residential.
IEC EN draft standard 26/708/CDV have been used to establish EU no. 2019/1784 data.
MIG 4004i Pulse is part of the ESAB Aristo product family.

By signing this document, the undersigned declares as manufacturer, or the manufacturer's authorised representative established within the EEA, that the equipment in question complies with the safety and environmental requirements stated above.

Place/Date

Göteborg
2020-12-16

Signature

Pedro Muniz
Standard Equipment Director

CE mark in 2020

1	SAFETY	4
1.1	Meaning of symbols	4
1.2	Safety precautions	4
2	INTRODUCTION	8
2.1	Equipment	8
3	TECHNICAL DATA	9
4	INSTALLATION	11
4.1	Location	11
4.2	Lifting instruction	11
4.3	Mains supply	11
5	OPERATION	15
5.1	Connections and control devices	16
5.2	Symbols	16
5.3	Connection of welding and return cable	16
5.4	Turning the power source on/off	17
5.5	Fan control	17
5.6	Thermal protection	17
5.7	VRD (Voltage Reducing Device)	17
5.8	Remote control unit	17
5.9	Arc voltage feedback	18
6	MAINTENANCE	19
6.1	Inspection and cleaning	19
7	TROUBLESHOOTING	20
8	ORDERING SPARE PARTS	21
	DIAGRAM	22
	ORDERING NUMBERS	23
	WEAR PARTS	24
	ACCESSORIES	25

1 SAFETY

1.1 Meaning of symbols

As used throughout this manual: Means Attention! Be Alert!

**DANGER!**

Means immediate hazards which, if not avoided, will result in immediate, serious personal injury or loss of life.

**WARNING!**

Means potential hazards which could result in personal injury or loss of life.

**CAUTION!**

Means hazards which could result in minor personal injury.

**WARNING!**

Before use, read and understand the instruction manual and follow all labels, employer's safety practices and Safety Data Sheets (SDSs).



1.2 Safety precautions

Users of ESAB equipment have the ultimate responsibility for ensuring that anyone who works on or near the equipment observes all the relevant safety precautions. Safety precautions must meet the requirements that apply to this type of equipment. The following recommendations should be observed in addition to the standard regulations that apply to the workplace.

All work must be carried out by trained personnel well-acquainted with the operation of the equipment. Incorrect operation of the equipment may lead to hazardous situations which can result in injury to the operator and damage to the equipment.

1. Anyone who uses the equipment must be familiar with:
 - its operation
 - location of emergency stops
 - its function
 - relevant safety precautions
 - welding and cutting or other applicable operation of the equipment
2. The operator must ensure that:
 - no unauthorised person is stationed within the working area of the equipment when it is started up
 - no-one is unprotected when the arc is struck or work is started with the equipment
3. The workplace must:
 - be suitable for the purpose
 - be free from drafts

4. Personal safety equipment:
 - Always wear recommended personal safety equipment, such as safety glasses, flame-proof clothing, safety gloves
 - Do not wear loose-fitting items, such as scarves, bracelets, rings, etc., which could become trapped or cause burns
5. General precautions:
 - Make sure the return cable is connected securely
 - Work on high voltage equipment **may only be carried out by a qualified electrician**
 - Appropriate fire extinguishing equipment must be clearly marked and close at hand
 - Lubrication and maintenance must **not** be carried out on the equipment during operation

**WARNING!**

Arc welding and cutting can be injurious to yourself and others. Take precautions when welding and cutting.

**ELECTRIC SHOCK - Can kill**

- Install and ground the unit in accordance with instruction manual.
- Do not touch live electrical parts or electrodes with bare skin, wet gloves or wet clothing.
- Insulate yourself from work and ground.
- Ensure your working position is safe

**ELECTRIC AND MAGNETIC FIELDS - Can be dangerous to health**

- Welders having pacemakers should consult their physician before welding. EMF may interfere with some pacemakers.
- Exposure to EMF may have other health effects which are unknown.
- Welders should use the following procedures to minimize exposure to EMF:
 - Route the electrode and work cables together on the same side of your body. Secure them with tape when possible. Do not place your body between the torch and work cables. Never coil the torch or work cable around your body. Keep welding power source and cables as far away from your body as possible.
 - Connect the work cable to the workpiece as close as possible to the area being welded.

**FUMES AND GASES - Can be dangerous to health**

- Keep your head out of the fumes.
- Use ventilation, extraction at the arc, or both, to take fumes and gases away from your breathing zone and the general area.

**ARC RAYS - Can injure eyes and burn skin**

- Protect your eyes and body. Use the correct welding screen and filter lens and wear protective clothing.
- Protect bystanders with suitable screens or curtains.

**NOISE - Excessive noise can damage hearing**

Protect your ears. Use earmuffs or other hearing protection.

MOVING PARTS - Can cause injuries



- Keep all doors, panels and covers closed and securely in place. Have only qualified people remove covers for maintenance and troubleshooting as necessary. Reinstall panels or covers and close doors when service is finished and before starting engine.



- Stop engine before installing or connecting unit.
- Keep hands, hair, loose clothing and tools away from moving parts.

FIRE HAZARD



- Sparks (spatter) can cause fire. Make sure that there are no inflammable materials nearby.
- Do not use on closed containers.

HOT SURFACE - Parts can burn



- Do not touch parts bare handed.
- Allow cooling period before working on equipment.
- To handle hot parts, use proper tools and/or insulated welding gloves to prevent burns.

MALFUNCTION - Call for expert assistance in the event of malfunction.

PROTECT YOURSELF AND OTHERS!



CAUTION!

This product is solely intended for arc welding.



WARNING!

Do not use the power source for thawing frozen pipes.



CAUTION!

Class A equipment is not intended for use in residential locations where the electrical power is provided by the public low-voltage supply system. There may be potential difficulties in ensuring electromagnetic compatibility of class A equipment in those locations, due to conducted as well as radiated disturbances.

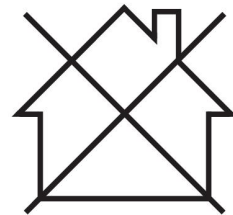



NOTE!

Dispose of electronic equipment at the recycling facility!

In observance of European Directive 2012/19/EC on Waste Electrical and Electronic Equipment and its implementation in accordance with national law, electrical and/or electronic equipment that has reached the end of its life must be disposed of at a recycling facility.

As the person responsible for the equipment, it is your responsibility to obtain information on approved collection stations.

For further information contact the nearest ESAB dealer.

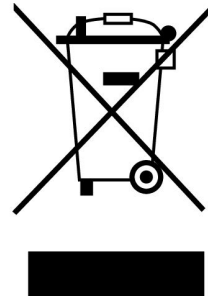

ESAB has an assortment of welding accessories and personal protection equipment for purchase. For ordering information contact your local ESAB dealer or visit us on our website.

2 INTRODUCTION

The power source **Mig 4004i Pulse** combined with U6, U8₂ or MA25 Pulse offer a complete multi-process package supporting MMA, TIG, MIG/MAG and pulse MIG.

The power source are intended for use with the wire feed unit Feed 3004/4804 or YardFeed 2000 and the cooling unit COOL 1. For more information about the feed units and the cooling unit, refer to the Instruction manuals.

ESAB accessories for the product can be found in the "ACCESSORIES" chapter of this manual.

2.1 Equipment

The power source is supplied with:

- 5 m return cable with earth clamp
- instruction manual for the welding power source

3 TECHNICAL DATA

Mig 4004i Pulse	
Mains voltage	380-460 V, $\pm 10\%$, 3~ 50/60 Hz
Mains supply S_{scmin}	5.8 MVA
Primary current I_{max}	28 A
No-load power	57 W
Setting range (DC)	
MIG/MAG	16 A / 14.8 V - 400 A / 34 V
MMA	16 A / 20.6 V - 400 A / 36 V
TIG	4 A / 10.2 V - 400 A / 26 V
Permissible load at MIG/MAG	
60 % duty cycle	400 A / 34.0 V
100% duty cycle	300 A / 29.0 V
Permissible load at MMA	
60 % duty cycle	400 A / 36.0 V
100% duty cycle	300 A / 32.0 V
Permissible load at TIG	
60 % duty cycle	400 A / 26.0 V
100% duty cycle	300 A / 22.0 V
Power factor at maximum current	0.95
Efficiency at maximum current	89.5 %
Open circuit voltage	55 V
Operating temperature	-10 to 40 °C (14 to 104 °F)
Transport temperature	-20 to 55 °C (-4 to 131 °F)
Constant sound pressure when idling	<70 dB (A)
Dimensions l×w×h	613 × 257 × 445 mm (24.0 × 10.1 × 17.5 in.)
Weight	48 kg (106 lb)
Insulation class	H
Enclosure class	IP23
Application classification	S

Mains supply, $S_{sc min}$

Minimum short circuit power on the network in accordance with IEC 61000-3-12.

Duty cycle

The duty cycle refers to the time as a percentage of a ten-minute period that you can weld or cut at a certain load without overloading. The duty cycle is valid for 40 °C / 104 °F, or below.

Enclosure class

The **IP** code indicates the enclosure class, i.e. the degree of protection against penetration by solid objects or water.

Equipment marked **IP23** is intended for indoor and outdoor use.

Application class

The symbol **S** indicates that the power source is designed for use in areas with increased electrical hazard.

4 INSTALLATION

The installation must be carried out by a professional.



CAUTION!

This product is intended for industrial use. In a domestic environment this product may cause radio interference. It is the user's responsibility to take adequate precautions.

4.1 Location

Position the welding power source such way that its cooling air inlets and outlets are not obstructed.

4.2 Lifting instruction

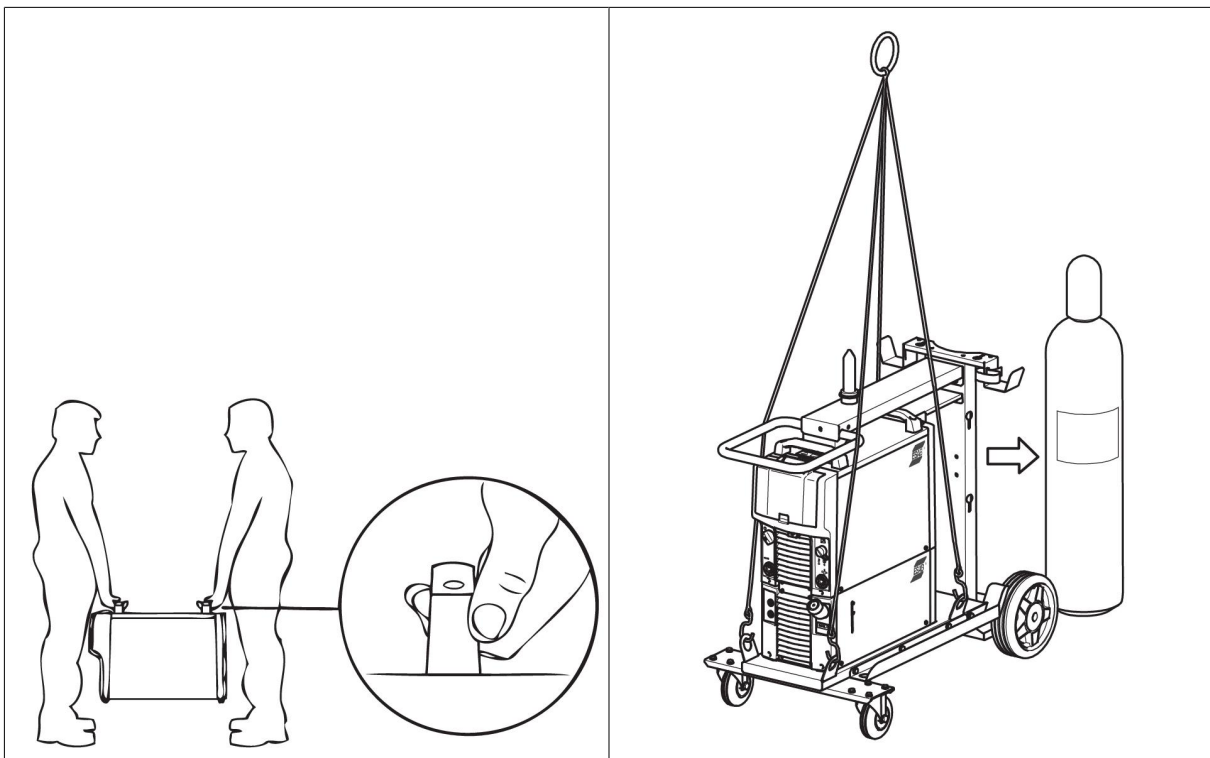

4.3 Mains supply



NOTE!

Mains supply requirements

This equipment complies with IEC 61000-3-12 provided that the short-circuit power is greater than or equal to S_{scmin} at the interface point between the user's supply and the public system. It is the responsibility of the installer or user of the equipment to ensure, by consultation with the distribution network operator if necessary, that the equipment is connected only to a supply with a short-circuit power greater than or equal to S_{scmin} . Refer to the technical data in the TECHNICAL DATA chapter.



NOTE!

The power source can be powered from a generator. For more information, contact authorised ESAB service personnel.

Check that the unit is connected to the correct mains power supply voltage, and that it is protected by the correct fuse size. A protective earth connection must be made, in accordance with regulations.

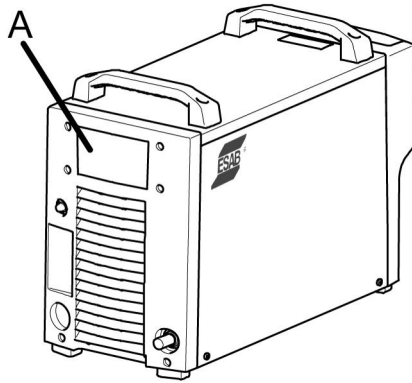

- A. Rating plate with supply connection data

Recommended fuse sizes and minimum cable areas

	Mig 4004i Pulse
Mains voltage	380-460 V, +/- 10%, 3~50/60 Hz
Mains cable area	4G4 mm ²
Phase current I_{eff} U_{in} 380 V	20 A
Fuse anti-surge	20 A
Fuse MCB-surge type C	25 A
Phase current I_{eff} U_{in} 400 V	19.2 A
Fuse anti-surge	20 A
Fuse MCB-surge type C	25 A
Phase current I_{eff} U_{in} 415 V	18 A
Fuse anti-surge	20 A
Fuse MCB-surge type C	20 A
Phase current I_{eff} U_{in} 440 V	17.6 A
Fuse anti-surge	20 A
Fuse MCB-surge type C	20 A
Phase current I_{eff} U_{in} 460 V	17 A
Fuse anti-surge	20 A
Fuse MCB-surge type C	20 A



NOTE!

The mains cable areas and fuse sizes as shown above are in accordance with Swedish regulations. For other regions, supply cables must be suitable for the application and meet local and national regulations.

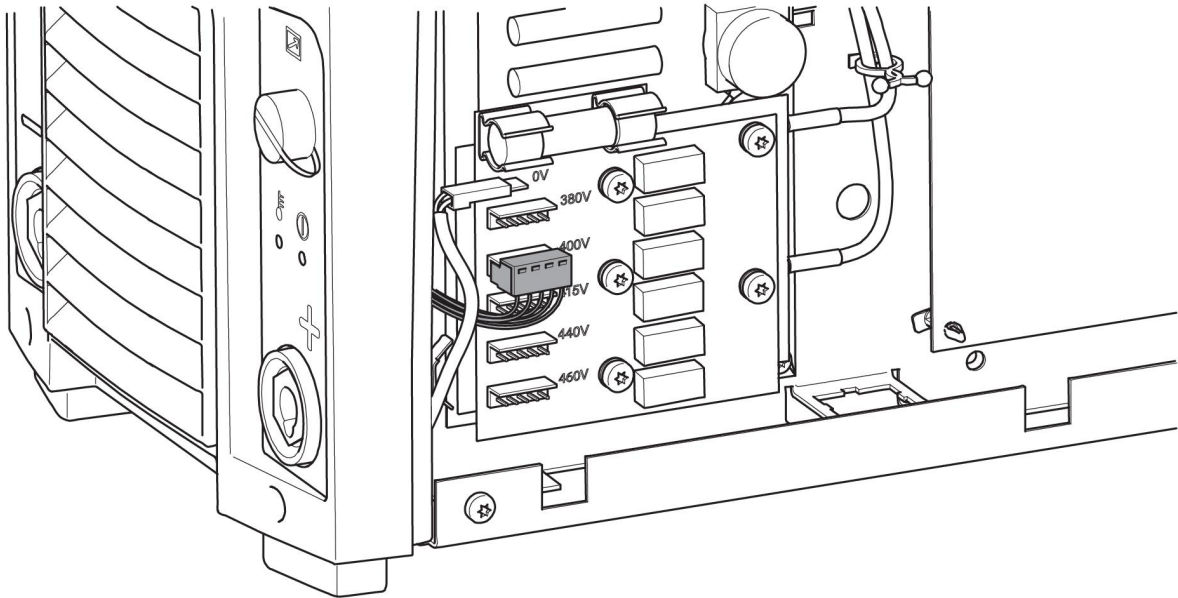
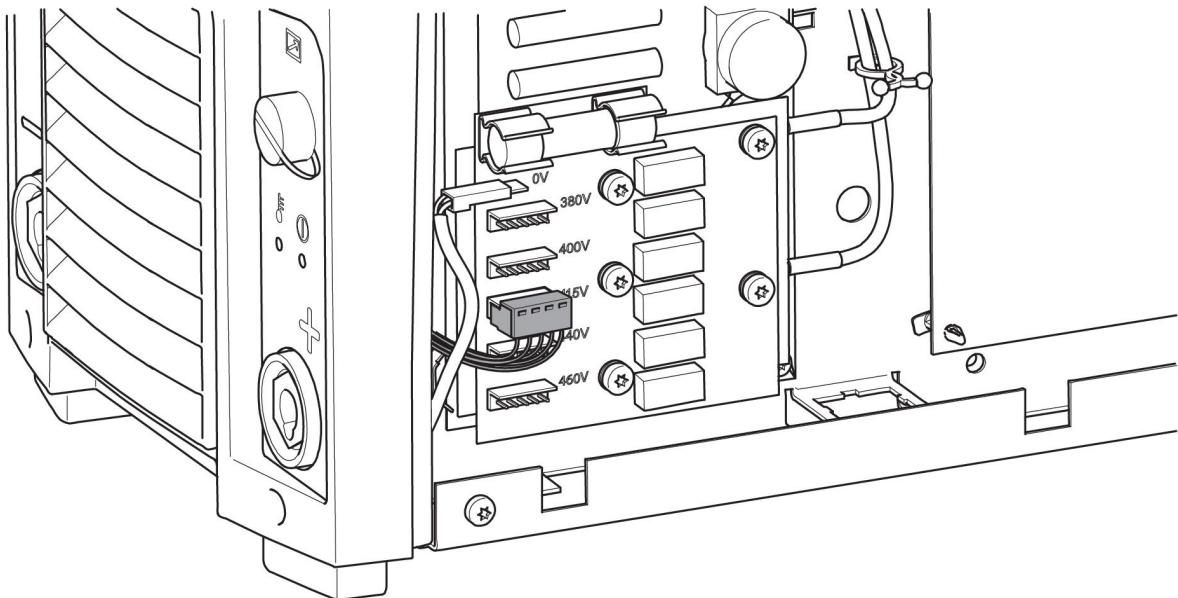
Connection instruction 0465 152 883**Connection instruction 0465 152 884****Power source ordering no.****Default input voltage setting**

0465 152 883

400 V

Delivered with mains cable and plug connected.

0465 152 884

415 V

Delivered with mains cable.

If another mains voltage is required, the cable on the printed circuit board has to be moved to the correct pin (see illustration above), and the mains cable and plug must be changed according to relevant national regulations. This operation has to be made by persons who have appropriate electrical knowledge. The power source must be disconnected from mains while performing this action.

5 OPERATION

General safety regulations for handling the equipment can be found in the "SAFETY" chapter of this manual. Read it through before you start using the equipment!



WARNING!

Secure the equipment - particularly if the ground is uneven or sloping.

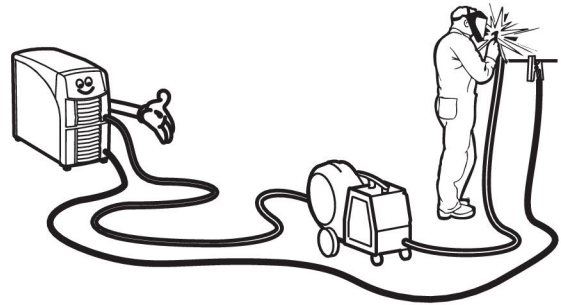
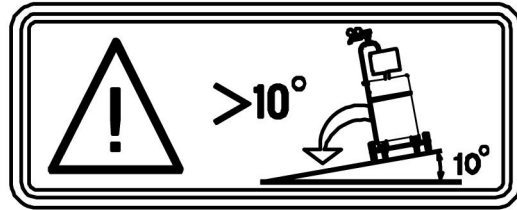

NOTE!

To achieve the best possible result at Mig short pulsing, the welding and return cables must not exceed 10 m (33 ft).

5.1 Connections and control devices

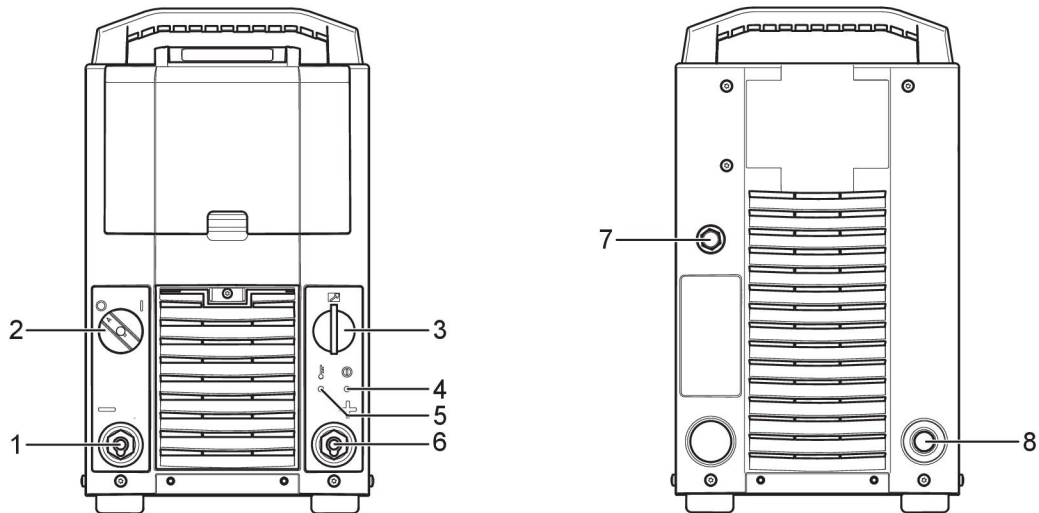

- | | |
|--|--|
| <ol style="list-style-type: none"> 1. Negative welding terminal: Return cable 2. Mains power supply switch, 0 / 1 3. Connection for wire feed unit or remote control unit 4. Indicating LED, power supply ON | <ol style="list-style-type: none"> 5. Indicating LED, thermal protection 6. Positive welding terminal: Welding cable 7. Fuse (10 A) for supply voltage (42 V) for feeder unit 8. Mains cable |
|--|--|

5.2 Symbols

	Remote control unit (2)		Overheating (3)
	Power supply ON (4)		

5.3 Connection of welding and return cable

The power source has two outputs, a positive terminal (+) and a negative terminal (-), for connecting welding and return cables.

Connect the return cable to the negative terminal on the power source. Secure the return cable's contact clamp to the work piece and ensure that there is good contact between the work piece and the output for the return cable on the power source.

Recommended maximum current values for connection set cables

I_{max}	Cable area	Cable length
450 A (60% duty cycle)	70 mm ²	2 - 35 m (6.6 ft - 114.8 ft)
350 A (100% duty cycle)		
550 A (60% duty cycle)	95 mm ²	2 - 35 m (6.6 ft - 114.8 ft)
430 A (100% duty cycle)		

Duty cycle

The duty cycle refers to the time as a percentage of a ten-minute period that you can weld or cut at a certain load without overloading. The duty cycle is valid for 40°C (104°F).

5.4 Turning the power source on/off

Turn the power source on by turning switch (2) to the "1" position. Turn the power source off by turning the switch (2) to the "0" position. Regardless the mains supply is interrupted abnormally or the power source is switched off in the normal manner, the welding data will be stored, so it will be available next time the unit is turned on.

5.5 Fan control

The power source has a time circuit, which keeps the fans running for 6.5 minutes after welding has stopped, after that the unit switches to energy-saving mode. The fans start again when welding begins. The fans run at reduced speed for welding currents up to 150 A, and at full speed for higher currents.

**CAUTION!**

The fans may start at any time to protect the power source from overheating.

5.6 Thermal protection

The welding power source has thermal protection circuit that operates if the internal temperature becomes too high. When this occurs the welding current is blocked and a fault code is displayed on the control panel. The thermal protection resets automatically when the temperature has fallen within normal operation temperature.

5.7 VRD (Voltage Reducing Device)

The VRD function ensures that the open-circuit voltage does not exceed 35 V when welding is not being carried out. VRD LED is lit when the VRD function is activated. The VRD function must be activated by a qualified service technician, by means of ESAT (ESAB Software Administration Tool, a kit for technical service including a software to manage settings, update of software etc.).

The VRD function is blocked when the system senses that welding has started.

5.8 Remote control unit

For more information about the operation of the remote control unit, see the instruction manual for the control panel.

5.9 Arc voltage feedback

To achieve a good welding result, the arc voltage feedback is a crucial factor. In MIG/MAG welding, the power source is prepared to sense the arc voltage in the wire feeder. Prerequisite for this functionality is that an ESAB wire feeder and an ESAB interconnection cable is used! This method of measuring the arc voltage, compensates for the voltage drop in the welding cable to the wire feeder. With an ESAB torch supporting "TrueArcVoltage", the voltage drop all the way to the contact tip is compensated.



WARNING!

The external arc voltage inputs (the red and black banana sockets) at the back end of the WeldCloud™ top box should **not** be used, unless the equipment has been configured for this setup by authorised ESAB service personnel.



NOTE!

To compensate the voltage drop in the return cable, the power source can be configured (by authorised ESAB service personnel) to use an external arc voltage sense wire from the workpiece.

6 MAINTENANCE

**CAUTION!**

Only persons with the appropriate electrical knowledge (authorised personnel) may remove the cover of the product or carry out service, maintenance or repair work on the welding equipment.

**CAUTION!**

The product is covered by manufacturer's warranty. Any attempt to carry out repair work by non-authorized service centers will invalidate the warranty.

**NOTE!**

Regular maintenance is important for safe and reliable operation.

For information about the cooling unit see the instruction manual for the cooling unit.

6.1 Inspection and cleaning

Check regularly that the power source is free from dirt.

The power source should be regularly blown clean using dry compressed air at reduced pressure. More frequently in dirty environments.

Otherwise the air inlet/outlet may become blocked and cause overheating. To avoid this, the air filter should be regularly cleaned. The filter is built of a large and a small mesh. Make sure that the large mesh is mounted to the upmost part of the power source and the small mesh to the innermost part of the power source.

Replacing and cleaning the dust filter:

1. Release the dust filter according to the figure.
2. Blow the filter clean with compressed air (reduced pressure).
3. Ensure that the filter with the finest mesh is placed towards the grill.
4. Reinstall the filter.

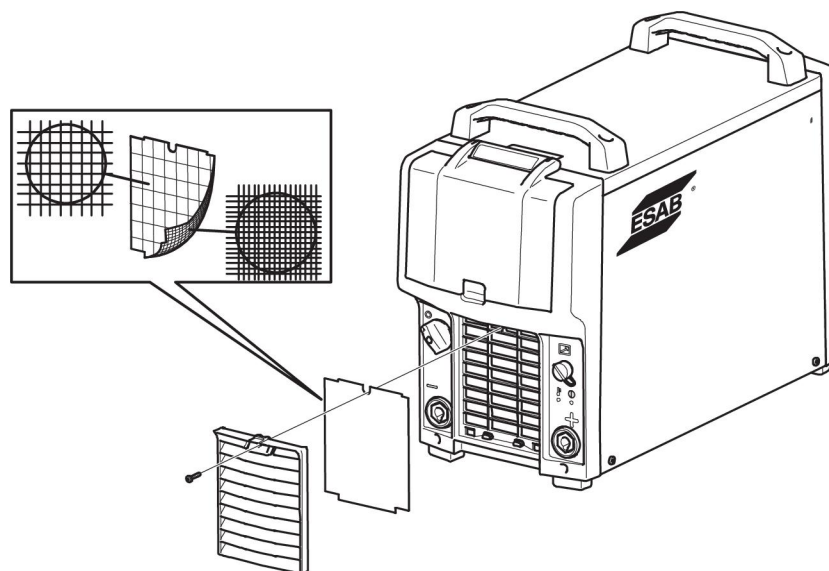

7 TROUBLESHOOTING

Try these recommended checks and inspections before sending for an authorised service technician.

Type of fault	Actions
No arc.	<ul style="list-style-type: none"> • Check that the mains power supply switch is turned on. • Check that the mains, welding current and return cables are correctly connected. • Check that the correct current value is set. • Check the mains power supply fuses.
Welding current is interrupted during welding	<ul style="list-style-type: none"> • Check whether the thermal protection trip has operated (indicated by the orange LED on the front (5)) • Check the main power supply fuses if the LED indicating power supply (4) is not lit. • Check that the return cable is correctly fastened.
The thermal protection trips frequently	<ul style="list-style-type: none"> • Check to see whether the air filters are clogged. • Make sure that you are not exceeding the rated data for the power source (i.e. that the unit is not being overloaded). • Check that the ambient temperature is not above the one for the rated duty cycle 40°C/104°F.
Poor welding performance.	<ul style="list-style-type: none"> • Check that the welding current and return cables are correctly connected. • Check that the correct current value is set. • Check that the correct welding wires are being used. • Check the mains power supply fuses.
Nothing happens when the trigger on the welding torch is pushed.	<ul style="list-style-type: none"> • Check the fuse on the rear part of the power source. • Check if the welding and return cables are damaged. • Check that the wire feeder works correctly. See the wire feeder instruction manual.

8 ORDERING SPARE PARTS



CAUTION!

Repair and electrical work should be performed by an authorised ESAB service technician. Use only ESAB original spare and wear parts.

Mig 4004i Pulse is designed and tested in accordance with the international and European standards **IEC-/EN 60974-1** and **IEC-/EN 60974-10**. It is the obligation of the service unit which has carried out the service or repair work to make sure that the product still conforms to the mentioned standards.

Spare parts and wear parts can be ordered through your nearest ESAB dealer, see [esab.com](https://www.esab.com). When ordering, please state product type, serial number, designation and spare part number in accordance with the spare parts list. This facilitates dispatch and ensures correct delivery.

DIAGRAM

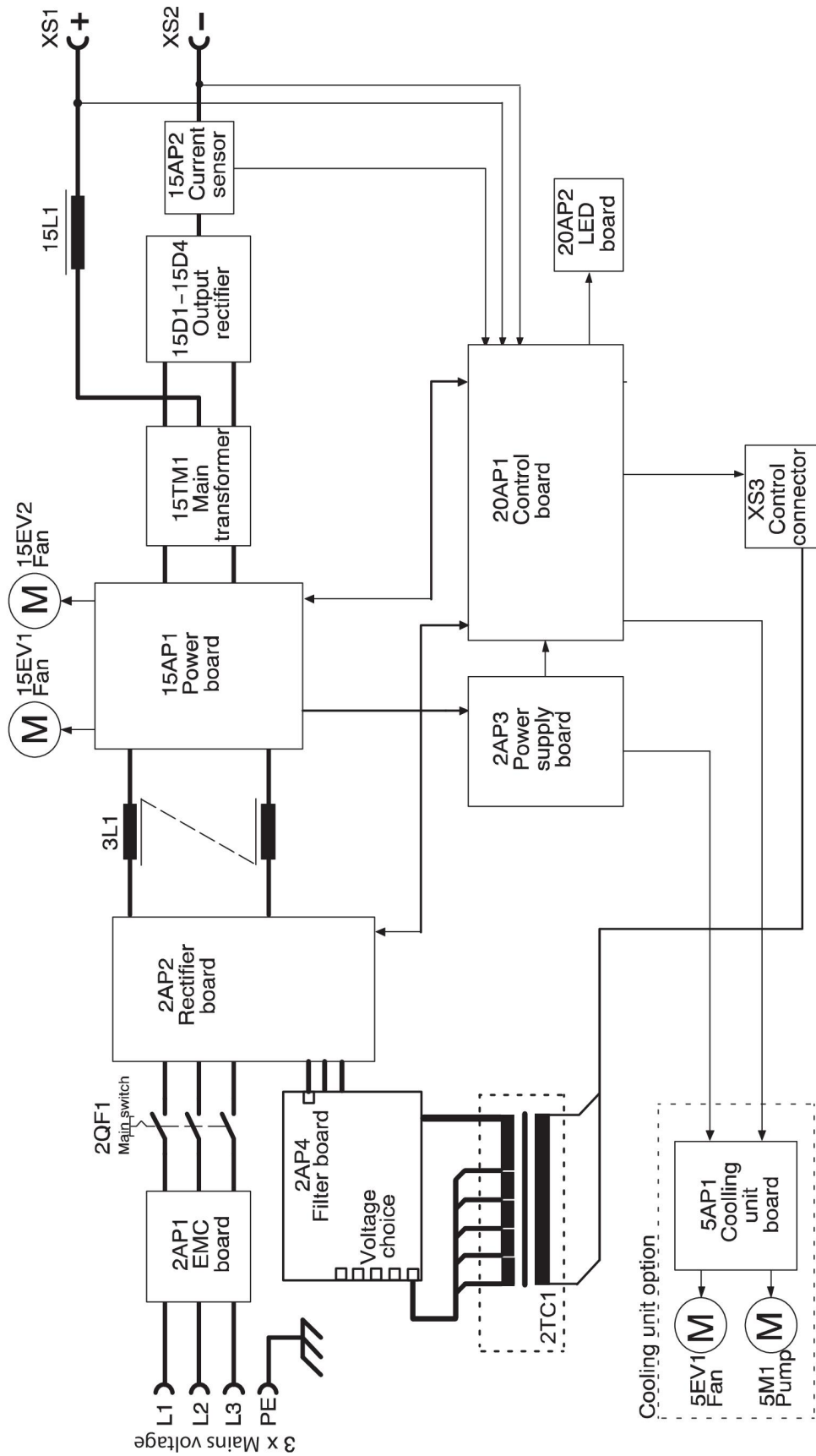

ORDERING NUMBERS

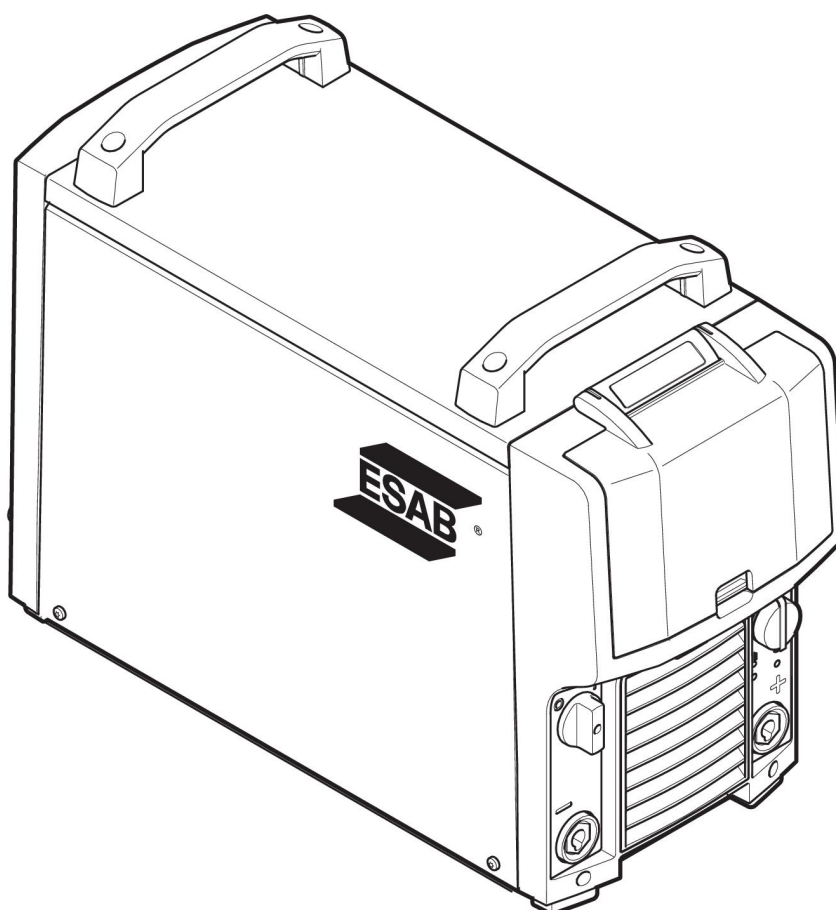

Ordering number	Denomination	Type	Note
0465 152 883	Welding power source	Aristo® Mig 4004i Pulse	380-460 V. CE
0465 152 884	Welding power source	Aristo® Mig 4004i Pulse	380-460 V. CE, AU
0463 396 001	Spare parts list	Mig 4004i Pulse, Mig 4004i Pulse WeldCloud™	

Technical documentation is available on the Internet at: www.esab.com

WEAR PARTS

Item	Ordering no.	Denomination
1	0462 197 001	Dust filter

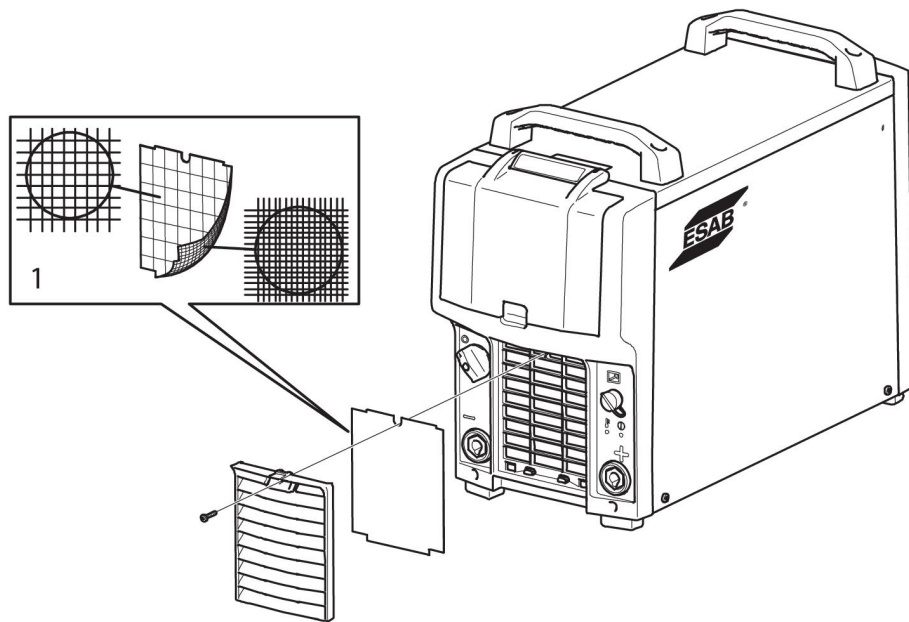

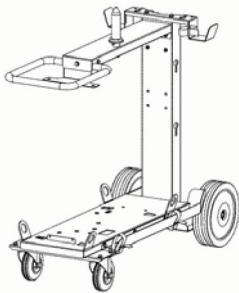
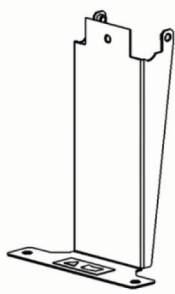
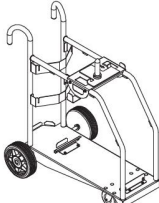
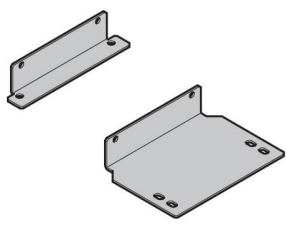
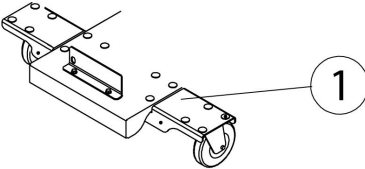
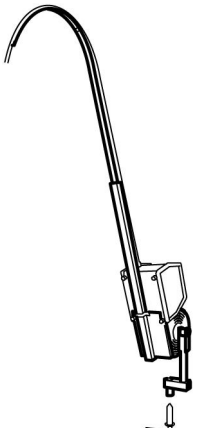

ACCESSORIES

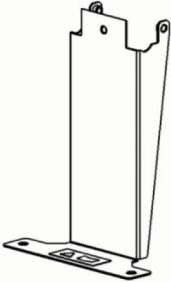
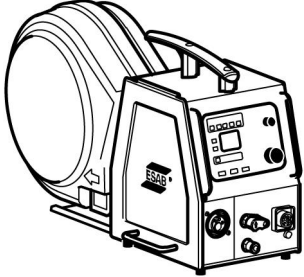
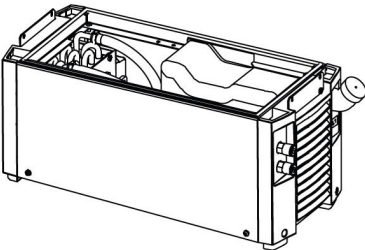
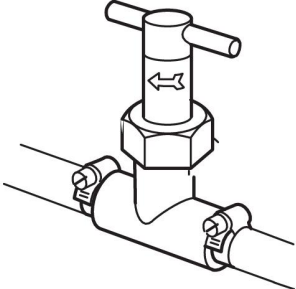

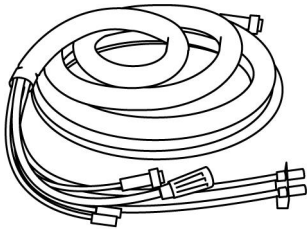

Trolleys		
0462 151 880	Trolley 11, 4-wheel	
0463 125 880	Trolley bracket for Trolley 11 Use together with trolley 0462 151 880. Option when no cooling unit is assembled.	
0460 565 880	Trolley For use together with counter balance device.	
0461 310 880	Trolley adapter kit For fitting of power source Mig 4004i Pulse to trolley 0460 565 880.	
0460 946 880	Stabilizer kit for counter balance (1) Use together with trolley 0460 565 880	
0458 705 880 0458 705 882	Counter balance device (includes mast and counter balance) for 300 mm (11 in.) bobbin for 440 mm (17 in.) bobbin	

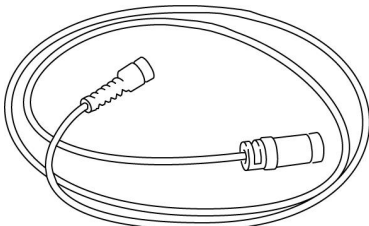
0463 125 880	<p>Trolley bracket</p> <p>Use together with trolley 0462 151 880.</p> <p>Option when no cooling unit is assembled</p>	
<p>Wire feeders</p>		
<p>0460 526 670</p> <p>0460 526 671</p> <p>0460 526 672</p> <p>0460 526 673</p> <p>0460 526 881</p> <p>0460 526 886</p> <p>0460 526 891</p> <p>0460 526 896</p> <p>0460 526 991</p> <p>0460 526 996</p> <p>0459 906 896</p> <p>0445 800 886</p> <p>0445 800 887</p>	<p>Feed 3004 MA25 Pulse Al</p> <p>Feed 3004w MA25 Pulse Al</p> <p>Feed 3004 MA25 Pulse Steel</p> <p>Feed 3004w MA25 Pulse Steel</p> <p>Feed 3004 U8₂</p> <p>Feed 3004 U6</p> <p>Feed 3004 U8₂, water-cooled</p> <p>Feed 3004 U6, water-cooled</p> <p>Feed 4804 U8₂, water-cooled</p> <p>Feed 4804 U6, water-cooled</p> <p>Yardfeed 2000, water-cooled</p> <p>Aristo® Robust Feed U0</p> <p>Aristo® Robust Feed U6</p>	
<p>Wire feeder accessories</p>		
<p>Accessories for wire feeders can be found in the wire feeder instruction manual.</p>		
<p>Cooler</p>		
0462 300 880	<p>Water cooling unit, COOL1</p>	
0456 855 881	<p>Flow guard, COOL1</p>	

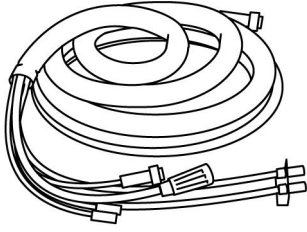
Connection set, 70 mm² 10 pole cable plug - 10 pole cable socket		
0459 528 780	1.7 m (5.6 ft)	
0459 528 781	5 m (16.0 ft)	
0459 528 782	10 m (32.8 ft)	
0459 528 783	15 m (49.2 ft)	
0459 528 784	25 m (82.0 ft)	
0459 528 785	35 m (114.8 ft)	

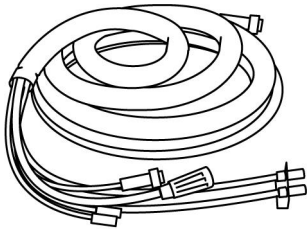
Control panels		
0460 820 880	Aristo®U8₂, complete including holder	
0460 820 881	Aristo®U8₂, plus complete including holder	
0460 877 891	Control cable extension U8₂, 7.5 m (24.6 ft)	

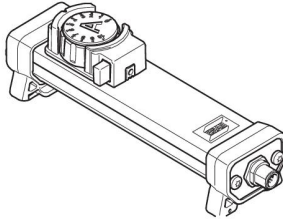
Connection set, 70 mm² 10 pole cable plug - 10 pole cable socket		
0349 312 450	1.7 m (5.6 ft)	
0349 312 451	5 m (16.0 ft)	
0349 312 452	10 m (32.8 ft)	
0349 312 453	15 m (49.2 ft)	
0349 312 454	25 m (82.0 ft)	
0349 312 455	35 m (114.8 ft)	

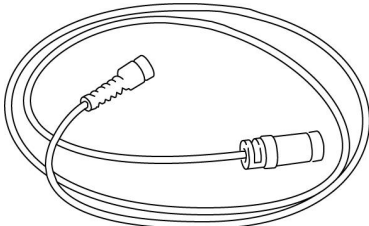
Connection set water, 70 mm² 10 pole cable plug - 10 pole cable socket		
0459 528 790	1.7 m (5.6 ft)	
0459 528 791	5 m (16.0 ft)	
0459 528 792	10 m (32.8 ft)	
0459 528 793	15 m (49.2 ft)	
0459 528 794	25 m (82.0 ft)	
0459 528 795	35 m (114.8 ft)	
Remote controls		
0459 491 880	Remote control unit MTA1 CAN MIG/MAG: wire feed speed and voltage MMA: current and arc force TIG: current, pulse and background current	
0459 491 883	Remote control unit AT1 CAN MMA and TIG: current	
0459 491 884	Remote control unit AT1 CF CAN MMA and TIG: rough and fine setting of current	
Remote control cable 10 pole - 4 pole		
0459 960 880	5 m (16.0 ft)	
0459 960 881	10 m (32.8 ft)	
0459 960 882	25 m (82.0 ft)	
0459 960 883	0.25 m (114.8 ft)	

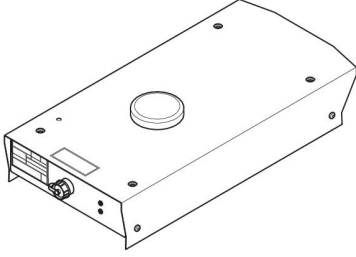
For Mig 4004i Pulse:		
0445 302 881	Retrofit Mig 4004i WeldCloud™	

Information on PSF welding torches can be found in separate brochures.

For more information about the accessories contact the nearest ESAB agency.



A WORLD OF PRODUCTS AND SOLUTIONS.



For contact information visit esab.com

ESAB AB, Lindholmsallén 9, Box 8004, 402 77 Gothenburg, Sweden, Phone +46 (0) 31 50 90 00

<http://manuals.esab.com>

