

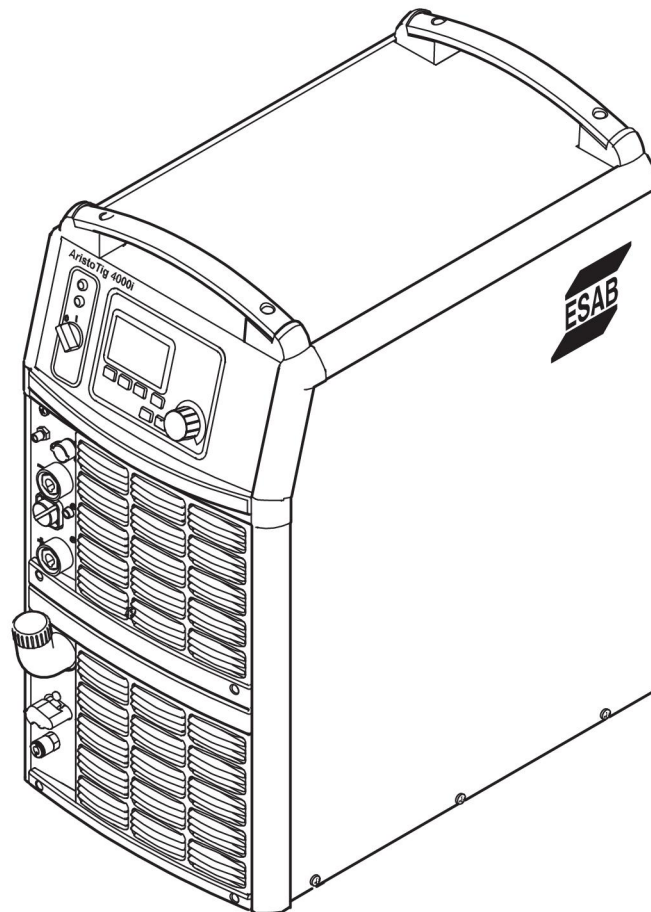

Aristo®

Tig 4000i / Tig 4000iw



Instruction manual



EU DECLARATION OF CONFORMITY

According to:

The Low Voltage Directive 2014/35/EU;
The RoHS Directive 2011/65/EU;

The EMC Directive 2014/30/EU;
The Ecodesign Directive 2009/125/EC

Type of equipment

Arc welding power source

Type designation

Tig 4000iw
Mig U4000iw

with serial number from 950 xxx xxxx (2009 w50)
with serial number from 950 xxx xxxx (2009 w50)

Brand name or trademark

ESAB

Manufacturer or his authorised representative established within the EEA

ESAB AB
Lindholmsallén 9, Box 8004, SE-402 77 Göteborg, Sweden
Phone: +46 31 50 90 00, www.esab.com

The following EN standards and regulations in force within the EEA has been used in the design:

EN IEC 60974-1:2018/A1:2019	Arc welding equipment - Part 1: Welding power sources
EN IEC 60974-2: 2019	Arc welding equipment - Part 2: Liquid cooling systems
EN IEC 60974-3:2019	Arc welding equipment - Part 3: Arc striking and stabilizing devices
EN 60974-10:2014/A1:2015, EU no. 2019/1784	Arc welding equipment - Part 10: Electromagnetic compatibility (EMC) Ecodesign requirements for welding equipment pursuant to Directive 2009/125/EC

Additional Information:

Restrictive use, Class A equipment, intended for use in locations other than residential.
IEC EN draft standard 26/708/CDV have been used to establish EU no. 2019/1784 data.
Tig 4000iw and Mig U4000iw are part of the ESAB Aristo product family.

By signing this document, the undersigned declares as manufacturer, or the manufacturer's authorised representative established within the EEA, that the equipment in question complies with the safety and environmental requirements stated above.

Place/Date

Göteborg
2020-12-17

Signature

Pedro Muniz
Standard Equipment Director

CE mark in 2020

1	SAFETY	4
1.1	Meaning of symbols	4
1.2	Safety precautions	4
2	INTRODUCTION	7
2.1	Equipment	7
2.2	The control panel.....	7
3	TECHNICAL DATA	8
4	INSTALLATION	10
4.1	Lifting instructions	10
4.2	Positioning of the power source.....	10
4.3	Mains power supply	11
5	OPERATION	12
5.1	Connections and control devices	12
5.2	Turning on the power source	12
5.3	Fan control	13
5.4	Overheating protection	13
5.5	Cooling unit.....	13
5.6	Remote control unit.....	13
6	MAINTENANCE	15
6.1	Daily	15
6.2	If necessary	15
6.3	Every year	16
7	TROUBLESHOOTING	17
8	ORDERING SPARE PARTS	18
	DIAGRAM	19
	ORDERING NUMBERS	22
	SPARE PARTS LIST	23
	ACCESSORIES	24

1 SAFETY

1.1 Meaning of symbols

As used throughout this manual: Means Attention! Be Alert!

**DANGER!**

Means immediate hazards which, if not avoided, will result in immediate, serious personal injury or loss of life.

**WARNING!**

Means potential hazards which could result in personal injury or loss of life.

**CAUTION!**

Means hazards which could result in minor personal injury.

**WARNING!**

Before use, read and understand the instruction manual and follow all labels, employer's safety practices and Safety Data Sheets (SDSs).



1.2 Safety precautions

Users of ESAB equipment have the ultimate responsibility for ensuring that anyone who works on or near the equipment observes all the relevant safety precautions. Safety precautions must meet the requirements that apply to this type of equipment. The following recommendations should be observed in addition to the standard regulations that apply to the workplace.

All work must be carried out by trained personnel well-acquainted with the operation of the equipment. Incorrect operation of the equipment may lead to hazardous situations which can result in injury to the operator and damage to the equipment.

1. Anyone who uses the equipment must be familiar with:
 - its operation
 - location of emergency stops
 - its function
 - relevant safety precautions
 - welding and cutting or other applicable operation of the equipment
2. The operator must ensure that:
 - no unauthorised person is stationed within the working area of the equipment when it is started up
 - no-one is unprotected when the arc is struck or work is started with the equipment
3. The workplace must:
 - be suitable for the purpose
 - be free from drafts

4. Personal safety equipment:
 - Always wear recommended personal safety equipment, such as safety glasses, flame-proof clothing, safety gloves
 - Do not wear loose-fitting items, such as scarves, bracelets, rings, etc., which could become trapped or cause burns
5. General precautions:
 - Make sure the return cable is connected securely
 - Work on high voltage equipment **may only be carried out by a qualified electrician**
 - Appropriate fire extinguishing equipment must be clearly marked and close at hand
 - Lubrication and maintenance must **not** be carried out on the equipment during operation

**WARNING!**

Arc welding and cutting can be injurious to yourself and others. Take precautions when welding and cutting.

**ELECTRIC SHOCK - Can kill**

- Install and ground the unit in accordance with instruction manual.
- Do not touch live electrical parts or electrodes with bare skin, wet gloves or wet clothing.
- Insulate yourself from work and ground.
- Ensure your working position is safe

**ELECTRIC AND MAGNETIC FIELDS - Can be dangerous to health**

- Welders having pacemakers should consult their physician before welding. EMF may interfere with some pacemakers.
- Exposure to EMF may have other health effects which are unknown.
- Welders should use the following procedures to minimize exposure to EMF:
 - Route the electrode and work cables together on the same side of your body. Secure them with tape when possible. Do not place your body between the torch and work cables. Never coil the torch or work cable around your body. Keep welding power source and cables as far away from your body as possible.
 - Connect the work cable to the workpiece as close as possible to the area being welded.

**FUMES AND GASES - Can be dangerous to health**

- Keep your head out of the fumes.
- Use ventilation, extraction at the arc, or both, to take fumes and gases away from your breathing zone and the general area.

**ARC RAYS - Can injure eyes and burn skin**

- Protect your eyes and body. Use the correct welding screen and filter lens and wear protective clothing.
- Protect bystanders with suitable screens or curtains.

**NOISE - Excessive noise can damage hearing**

Protect your ears. Use earmuffs or other hearing protection.

MOVING PARTS - Can cause injuries



- Keep all doors, panels and covers closed and securely in place. Have only qualified people remove covers for maintenance and troubleshooting as necessary. Reinstall panels or covers and close doors when service is finished and before starting engine.



- Stop engine before installing or connecting unit.
- Keep hands, hair, loose clothing and tools away from moving parts.

FIRE HAZARD



- Sparks (spatter) can cause fire. Make sure that there are no inflammable materials nearby.
- Do not use on closed containers.

MALFUNCTION - Call for expert assistance in the event of malfunction.

PROTECT YOURSELF AND OTHERS!



CAUTION!

This product is solely intended for arc welding.



WARNING!

Do not use the power source for thawing frozen pipes.



CAUTION!

Class A equipment is not intended for use in residential locations where the electrical power is provided by the public low-voltage supply system. There may be potential difficulties in ensuring electromagnetic compatibility of class A equipment in those locations, due to conducted as well as radiated disturbances.

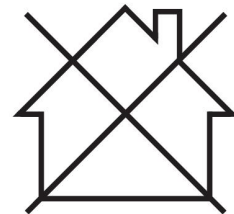

NOTE!

Dispose of electronic equipment at the recycling facility!

In observance of European Directive 2012/19/EC on Waste Electrical and Electronic Equipment and its implementation in accordance with national law, electrical and/or electronic equipment that has reached the end of its life must be disposed of at a recycling facility.

As the person responsible for the equipment, it is your responsibility to obtain information on approved collection stations.

For further information contact the nearest ESAB dealer.



ESAB has an assortment of welding accessories and personal protection equipment for purchase. For ordering information contact your local ESAB dealer or visit us on our website.

2 INTRODUCTION

The **Tig 4000i/Tig 4000iw** is a TIG welding power source, which can also be used for MMA welding.

ESAB accessories for the product can be found in the "ACCESSORIES" chapter of this manual.

2.1 Equipment

The Tig 4000i/Tig 4000iw is delivered with 5m return cable, instruction manual for power source and one instruction manual for the control panel.

Instruction manuals in other languages can be downloaded from the Internet: www.esab.com

2.2 The control panel

The power source is supplied with one of the following control panels:

- **TA4 panel**



With a knob for adjusting the current. Other parameters are controlled by pushbuttons, with symbols in the display panel.

- **TA6 panel**



With a knob for adjusting the current. Other parameters are controlled by pushbuttons, with text in the display panel.

See the separate instruction manuals for detailed descriptions of the control panels.

3 TECHNICAL DATA

Tig 4000i/Tig 4000iw	
Mains voltage	400 V \pm 10 %, 3 ~ 50 Hz
Mains supply	S _{sc min} 6.1 MVA
Primary current	
I _{max} TIG	22 A
I _{max} MMA	28 A
No-load power in energy-saving mode 6.5 min. after welding	39 W
Voltage/current range	
TIG	10 – 26 V / 4 – 400 A
MMA	20.6 – 36.0 V / 16 – 400 A
Permissible load at TIG	
35% duty cycle	400 A / 26 V
60% duty cycle	320 A / 23 V
100% duty cycle	250 A / 20 V
Permissible load at MMA	
35% duty cycle	400 A / 36 V
60% duty cycle	320 A / 33 V
100% duty cycle	250 A / 30 V
Power factor at maximum current	0.90
Efficiency at maximum current	81.2 %
Open-circuit voltage U₀ max	
without VRD function ¹⁾	78 – 90 V
U _{0L} "Live TIG" , VRD function deactivated ²⁾	60 V
MMA, VRD function deactivated ²⁾	60 V
VRD function activated ²⁾	< 26 V
Operating temperature range	-10 to +40 °C (+14 to +104 °F)
Transportation temperature	-20 to +55 °C (-4 to +131 °F)
Dimensions l × w × h	625 × 394 × 776 (24.6 × 15.5 × 30.5 in.)
Continual sound pressure at no-load	< 70 db (A)
Weight	84 kg (185 lbs)
Insulation class	H
Enclosure class	IP23
Application class	S

1) Valid for power sources without VRD specification on the rating plate.

2) Valid for power sources with VRD specification on the rating plate. The VRD function is explained in the instructions for the control panel, if the panel has that function.

Duty cycle

The duty cycle refers to the time as a percentage of a ten-minute period that you can weld or cut at a certain load without overloading. The duty cycle is valid for 40 °C / 104 °F, or below.

Enclosure class

The **IP** code indicates the enclosure class, i.e. the degree of protection against penetration by solid objects or water.

Equipment marked **IP23** is intended for indoor and outdoor use.

Application class

The symbol **S** indicates that the power source is designed for use in areas with increased electrical hazard.

Mains supply, $S_{SC \min}$

Minimum short circuit power on the network in accordance with IEC 61000-3-12.

Cooling unit (Tig 4000iw)	
Cooling power	50 Hz – 1.65 kW at 25 °C (77 °F) ambient temperature and flow 1.0 l/min (0.26 gal/min)
	60 Hz – 1.55 kW at 25 °C (77 °F) ambient temperature and flow 1.0 l/min (0.26 gal/min)
Coolant	ESAB's ready mixed coolant
Liquid quantity	5.5 l (1.45 gal)
Maximum water flow	2.0 l/min (0.53 gal/min)
Maximum number of water-cooled welding torches that may be connected	One TIG torch and one MIG welding torch
Maximum pressure	50 Hz – 0.376 MPa (3.76 Bar)
	60 Hz – 0.474 MPa (4.74 Bar)

4 INSTALLATION

The installation must be carried out by a professional.





NOTE!

Mains supply requirements

This equipment complies with IEC 61000-3-12 provided that the short-circuit power is greater than or equal to S_{scmin} at the interface point between the user's supply and the public system. It is the responsibility of the installer or user of the equipment to ensure, by consultation with the distribution network operator if necessary, that the equipment is connected only to a supply with a short-circuit power greater than or equal to S_{scmin} . Refer to the technical data in the TECHNICAL DATA chapter.

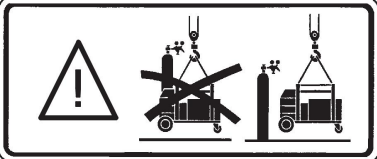
4.1 Lifting instructions

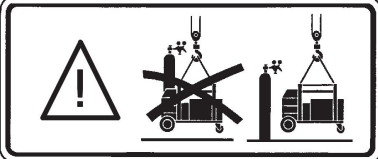
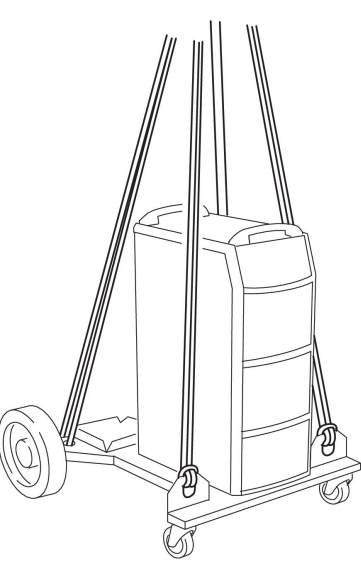
With power source	With trolley and power source	With trolley2 and power source
	<div data-bbox="608 875 986 1032" style="border: 1px solid black; padding: 5px; margin-bottom: 10px;">  </div> 	<div data-bbox="1011 875 1390 1032" style="border: 1px solid black; padding: 5px; margin-bottom: 10px;">  </div> 

4.2 Positioning of the power source

Position the welding power source in such a way that its cooling air inlets and outlets are not obstructed.

4.3 Mains power supply

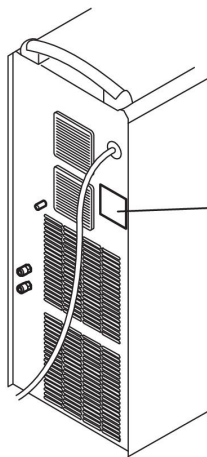

Check that the unit is connected to the correct mains power supply voltage, and that it is protected by the correct fuse sizes. A protective earth connection must be made, in accordance with regulations.

Rating plate with supply connection data.

Recommended fuse sizes and minimum cable areas

Tig 4000i/Tig 4000iw	50 Hz
Mains voltage	400 V
Mains cable area, mm²	4G4
Phase current, $I_{1\text{eff}}$	16 A
Fuse	
Anti-surge	20 A
Type C MCB	20 A



NOTE!

The mains cable areas and fuse sizes as shown above are in accordance with Swedish regulations. For other regions, supply cables must be suitable for the application and meet local and national regulations.

5 OPERATION

General safety regulations for handling the equipment can be found in the "SAFETY" chapter of this manual. Read it through before you start using the equipment!

5.1 Connections and control devices

- | | | | |
|---|--|----|---|
| 1 | Connection for cooling water from the TIG torch - RED | 9 | Main power supply switch, 0 / 1 / START torch - RED |
| 2 | Connection with water lock for cooling water to the TIG torch - BLUE | 10 | White indicating lamp - Power supply ON |
| 3 | Cooling water filler | 11 | Orange indicating lamp - Overheating |
| 4 | Connection for return cable (+) | 12 | Control panel (see the respective instructions) |
| 5 | Connection for remote control | 13 | Connection for gas hose |
| 6 | Connection for welding cable (-) | 14 | Connection for cooling water. Not used on this model. |
| 7 | Connection for start signal from the welding torch | 15 | Connection for cooling water. Not used on this model. |
| 8 | Connection for gas to the TIG torch | | |

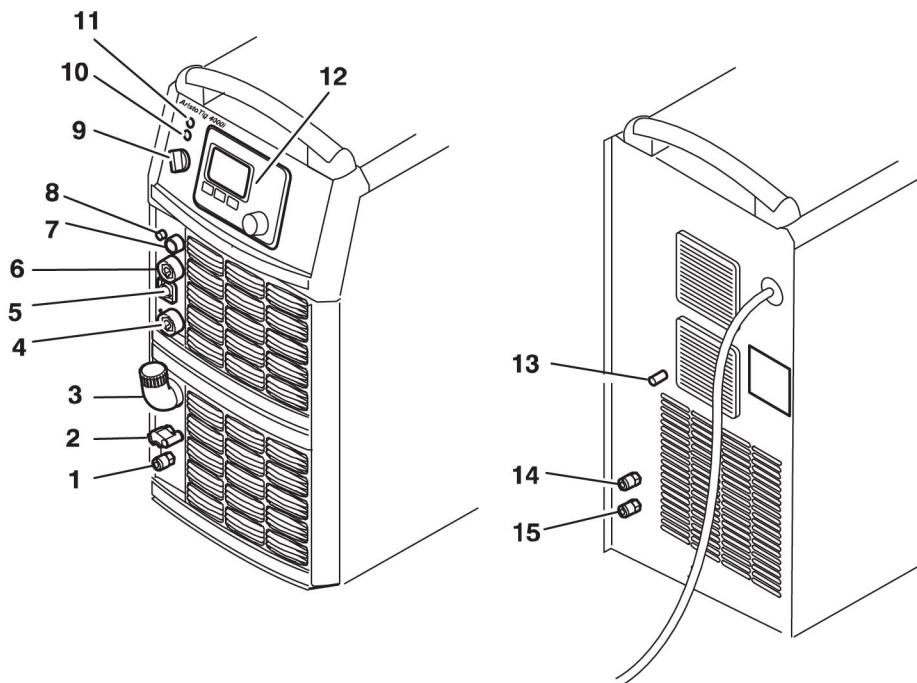

5.2 Turning on the power source

Turn on the mains power by turning switch (9) to the "START" position. Release the switch, and it will return to the "1" position.

If the mains power supply should be interrupted while welding is in progress, and then be restored, the power source will remain de-energised until the switch is again turned manually to the "START" position.

Turn the unit off by turning the switch to the "0" position

Whether in the event of a loss of power supply or of turning the power source off in the normal manner, welding data will be stored so that it is available next time the unit is started.

5.3 Fan control

The power source fans continue to run for 6.5 minutes after welding has stopped, and the unit switches to energy-saving mode. They start again when welding restarts.

The fans run at reduced speed for welding currents up to 144 A, and at full speed for higher currents.

5.4 Overheating protection

The power source has two thermal overload trips which operate if the internal temperature becomes too high, interrupting the welding current and lighting the orange indicating lamp on the front of the unit. They reset automatically when the temperature has fallen.

5.5 Cooling unit

Water lock

The cooling unit has a water lock that senses whether the cooling water hoses are connected.

The power source On/Off switch must be in the "0" position (Off) when connecting a water-cooled TIG torch.

If a water-cooled TIG torch is connected, the water pump starts automatically when the main On/Off switch is turned to "START" and/or when welding starts. After welding, the pump continues to run for 6.5 minutes, and then switches to the energy-saving mode.

Function when welding

To start welding, the welder presses the torch trigger switch. The power source energises the torch and starts wire feed and the cooling water pump.

To stop welding, the welder releases the torch trigger switch. The welding current is interrupted, but the cooling water pump continues to run for 6.5 minutes, after which the unit switches to energy-saving mode.

Water flow guard (optional)

The water flow guard interrupts the welding current in the event of loss of coolant, and displays an error message on the control panel. The water flow guard is an accessory.

5.6 Remote control unit

Aristo power sources with integral control panels should have program version 1.21 or higher, in order for the remote control to function correctly.

When the remote control unit is connected, the power source and wire feed unit are in remote control mode; the buttons and knobs are blocked. The functions can only be adjusted via the remote unit.

If the remote control unit is not to be used, the remote control unit must be disconnected from the power source / wire feed unit, as otherwise it will remain in remote control mode.

When carrying out TIG welding, the value for the pulse current can be changed with the remote control.

For more information about the operation of the remote control unit, see the relevant operating instructions for the control panel.

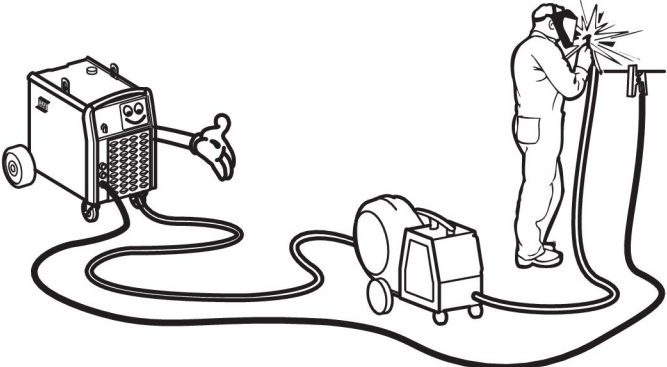
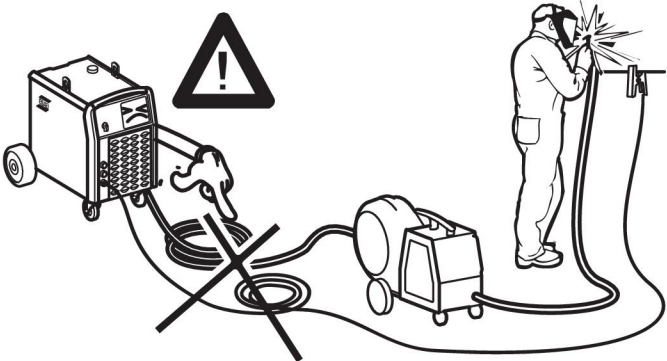

6 MAINTENANCE



NOTE!

Regular maintenance is important for safe and reliable operation.

Only those persons who have appropriate electrical knowledge (authorised personnel) may remove the safety plates to connect or carry out service, maintenance or repair work on welding equipment.



CAUTION!

All warranty undertakings from the supplier cease to apply if the customer attempts any work to rectify any faults in the product during the warranty period.

6.1 Daily

Carry out the following maintenance every day.

- Check that all cables and connections are fault free. Tighten if necessary and replace any defective parts.
- Check the water level and water flow, top up with coolant if necessary.

6.2 If necessary

- Regularly check that the power source is not clogged with dirt. Clogged or blocked air inlets and outlets result in overheating
- Clean the dust filter
 - Remove the fan grille with the dust filter (1).
 - Swing out the grille (2).
 - Release the dust filter (3).
 - Blow the filter clean with compressed air (reduced pressure).
 - Replace the filter with the finer mesh on the side against the grille (2) (out from the power source).
 - Replace the fan grille with the dust filter.

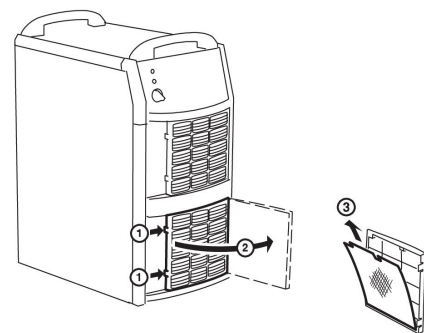

- Top up with coolant
ESAB's ready mixed coolant is recommended for use.
See "ACCESSORIES" chapter.
 - Top up with coolant until it covers half the inlet pipe.

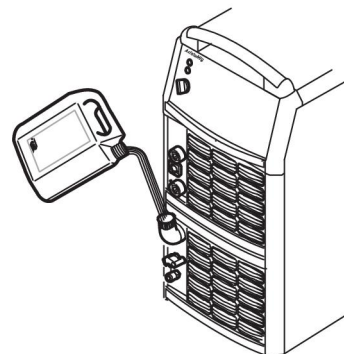

CAUTION!

The coolant must be handled as chemical waste.

6.3 Every year

Carry out the following maintenance at least once a year.

- Clean off any dirt and dust. Blow the power source clean with dry compressed air (reduced pressure).
- Change the coolant and clean the hoses and water reservoir with clean water.
- Check seals, cables and connections. Tighten if necessary and replace any defective parts.

7 TROUBLESHOOTING

Try these recommended checks and inspections before sending for an authorised service technician.

Type of fault	Action
No arc	<ul style="list-style-type: none"> • Check that the mains power supply switch is turned on. • Check that the welding current supply and return cables are correctly connected. • Check that the correct current value is set.
Welding current is interrupted during welding	<ul style="list-style-type: none"> • Check whether the thermal overload trips have operated (indicated by the orange lamp on the front panel). • Check the main power supply fuses.
The thermal overload trips operate frequently.	<ul style="list-style-type: none"> • Check to see whether the air filters are clogged. • Make sure that you are not exceeding the rated data for the power source (i.e. that the unit is not being overloaded).
Poor welding performance.	<ul style="list-style-type: none"> • Check that the welding current supply and return cables are correctly connected. • Check that the correct current value is set. • Check that the correct electrodes are being used. • Check the main power supply fuses.

8 ORDERING SPARE PARTS



CAUTION!

Repair and electrical work should be performed by an authorised ESAB service technician. Use only ESAB original spare and wear parts.

Tig 4000i/Tig 4000iw is designed and tested in accordance with the international and European standards **IEC-/EN 60974-1, /-2, /-3** and **IEC-/EN 60974-10**. It is the obligation of the service unit which has carried out the service or repair work to make sure that the product still conforms to the mentioned standards.

Spare parts and wear parts can be ordered through your nearest ESAB dealer, see [esab.com](https://www.esab.com). When ordering, please state product type, serial number, designation and spare part number in accordance with the spare parts list. This facilitates dispatch and ensures correct delivery.

DIAGRAM

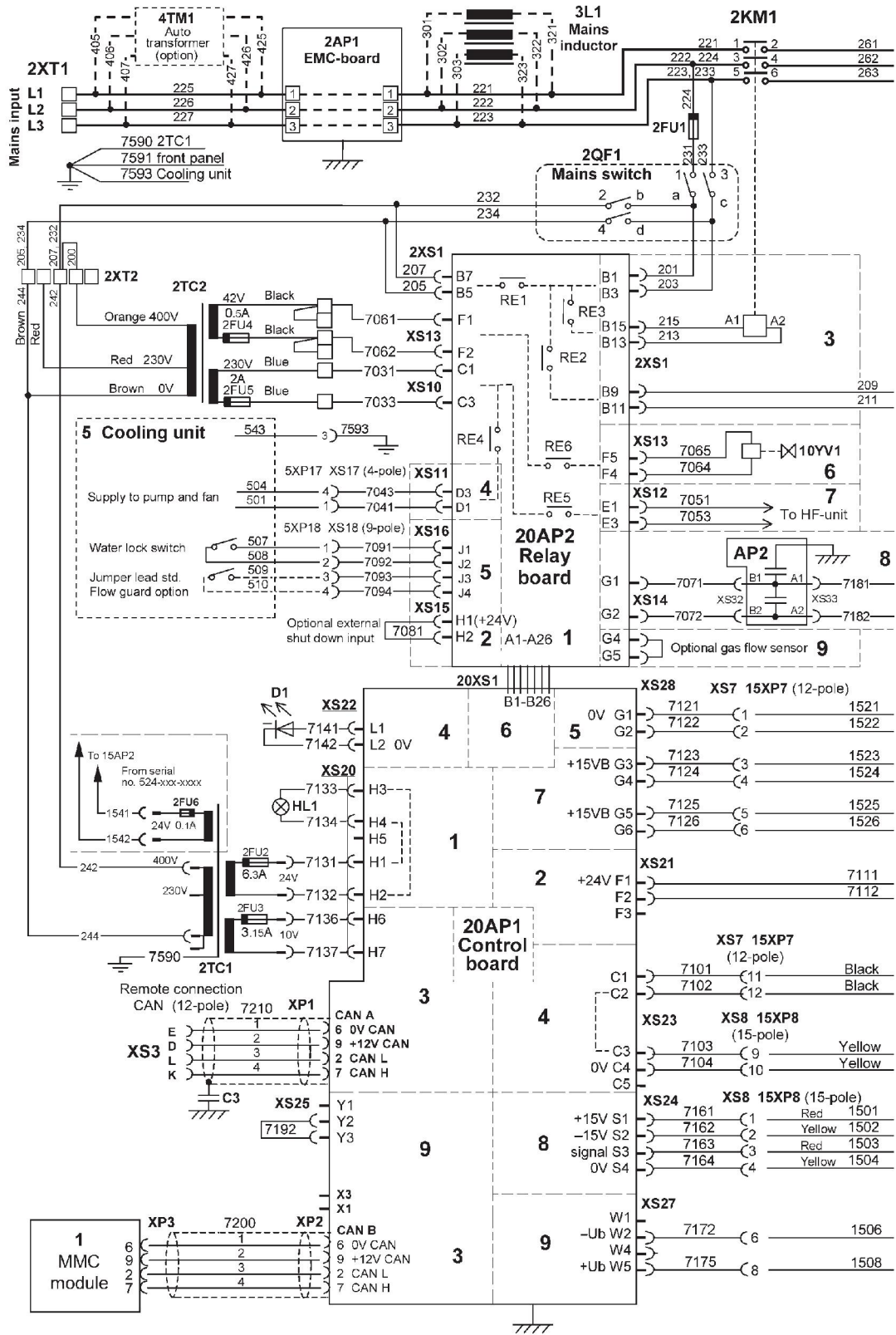

Cooling unit

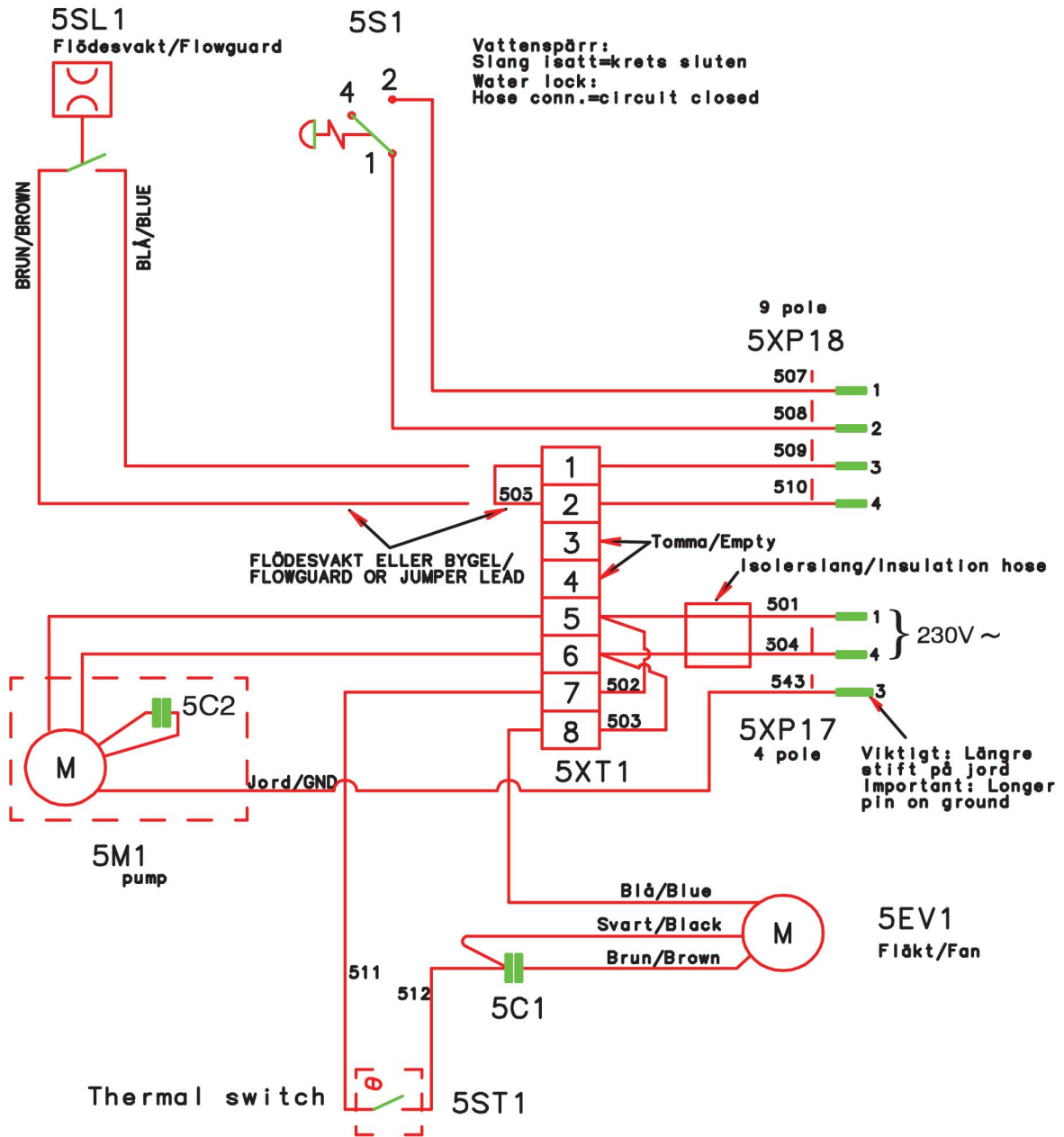

ORDERING NUMBERS

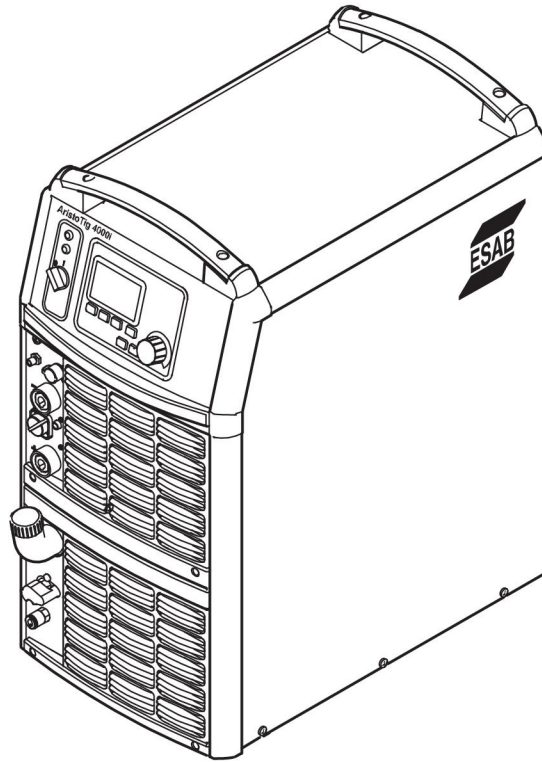

Ordering no.	Denomination	Type	Notes
0458 630 881	Welding power source	Aristo®Tig 4000iw TA4 400V	with cooling unit
0458 630 885	Welding power source	Aristo®Tig 4000iw TA6 400V	with cooling unit
0458 640 990	Spare parts list	Aristo®Tig 4000iw	
0458 819 xxx	Instruction manual	Aristo® TA4	
0458 855 xxx	Instruction manual	Aristo® TA6	

Instruction manuals and the spare parts list are available on the Internet at: www.esab.com

SPARE PARTS LIST

Item	Ordering no.	Denomination
1	0458 398 001	Filter
2	0458 383 991	Front grill

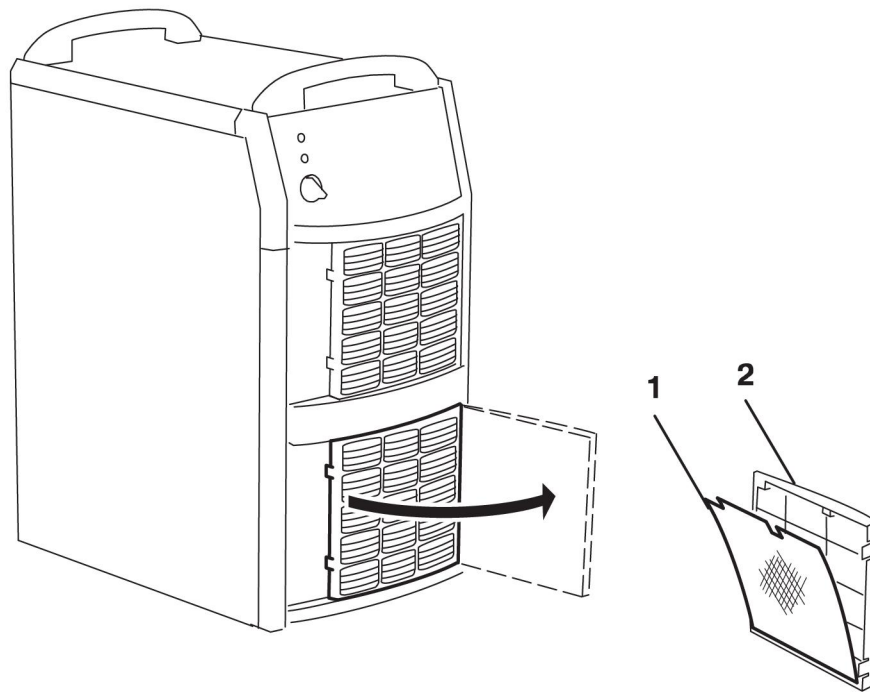

ACCESSORIES

0458 530 881	Trolley	
0459 145 880	Autotransformer TUA2	
0459 491 910	Remote control adapter RA12 12 pole For analogue remote controls to CAN based equipment.	
0459 491 880	Remote control unit MTA1 CAN MIG/MAG: wire feed speed and voltage MMA: current and arc force TIG: current, pulse and background current	
0459 491 882	Remote control unit M1 10Prog CAN Choice of one of 10 programs MIG/MAG: voltage deviation TIG and MMA: current deviation	
0459 491 883	Remote control unit AT1 CAN MMA and TIG: current	
0459 491 884	Remote control unit AT1 CF CAN MMA and TIG: rough and fine setting of current.	

ACCESSORIES

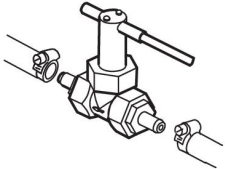
0460 315 880	<p>Remote control unit T1 Foot CAN For CAN based TIG equipment</p>	
<p>0459 554 880 0459 554 881 0459 554 882 0459 554 883 0459 554 884</p>	<p>Remote cable CAN 4 pole - 12 pole 5 m 10 m 15 m 25 m 0.25 m</p>	
0700 006 895	<p>Return cable 5 m 70 mm²</p>	
0456 855 880	<p>Water flow guard 0.7 l/min</p>	
0465 720 002	<p>ESAB ready mixed coolant (10 l / 2.64 gal) Use of any other cooling liquid than the prescribed one might damage the equipment. In case of such damage, all warranty undertakings from ESAB cease to apply.</p>	



A WORLD OF PRODUCTS AND SOLUTIONS.



For contact information visit esab.com

ESAB AB, Lindholmsallén 9, Box 8004, 402 77 Gothenburg, Sweden, Phone +46 (0) 31 50 90 00

<http://manuals.esab.com>

