

WHEEL CART KIT

P/N 34324

The Wheel Cart is an accessory that permits rolling a Mig 4HD, Mig 2E, DuraDrive 4-30 or DuraDrive 4-48HD Wire Feeder or a PCM-500i or PCM-875 Plasma Power Source around the job site with ease.

The kit includes the following parts:

- 1 - Base, 34138
- 2 - Swivel Wheel, 950396
- 2 - Stationary Wheel, 950472
- 1 - Strap 34146
- 2 - Clip, 36905
- 2 - Screw, 1/4"-20 x 0.50"
- 16 - Nut, 1/4"-20
- 18 - Lockwasher, 1/4"
- 4 - Screw, #10-32 x .38LG
- 4 - Lockwasher #10

Assemble as follows:

1. Assemble stationary casters on one end of cart base and the swivel casters on the other using 16 supplied lockwashers and nuts. Tighten each nut firmly.
2. If using the cart for the Mig 4HD or 2E Wire Feeder, position the wire feeder on the cart and then secure to cart with the supplied strap (34146) and two screws and lockwashers as illustrated. Tighten all screws firmly.

Mig 4HD and 2E

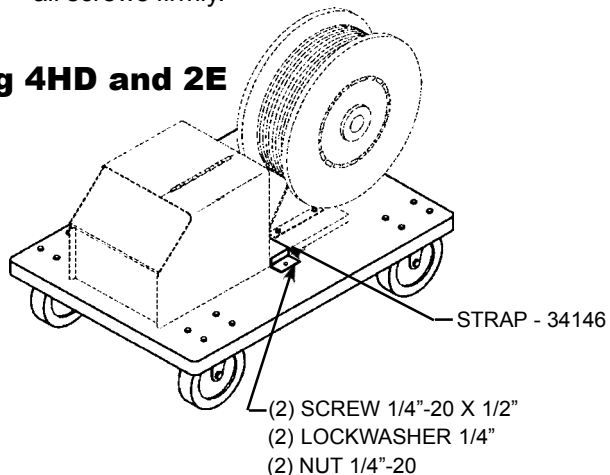

3. If using the cart for PCM-500i or 875, position the unit on the cart as shown. Remove the bottom middle panel mounting screw and assemble the supplied right angle clip (36905) with the same panel mounting screw to each side of the unit. Secure the unit to the base using two supplied screws, lockwashers and nuts. Make sure all screws are tightened firmly,

Instructions for the DuraDrive 4-30 or DuraDrive 4-48 Wire Feeder are found on the back of this publication.

PCM-500i and 875

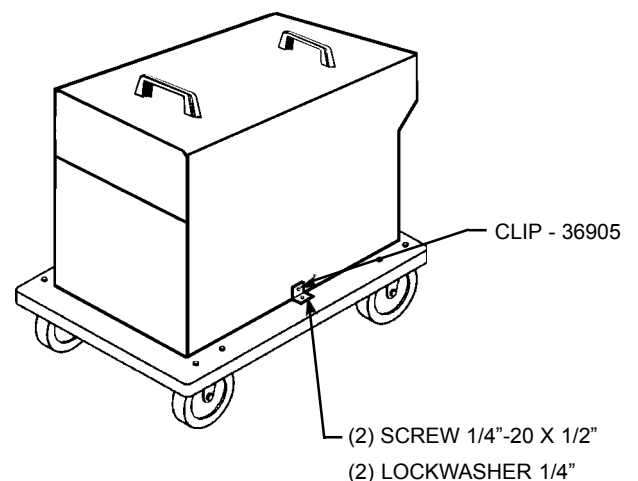

**Be sure this information reaches the operator.
You can get extra copies through your supplier.**

- If using the cart for the DuraDrive 4-30 or DuraDrive 4-48 Wire Feeder, position the Wire Feeder on the cart, secure the two supplied right angle clips (36905) at the front and rear of the feeder using the screws and lockwashers supplied. Secure the clips to the cart using supplied screws and lockwashers as shown below. Make sure all screws are tightened firmly.



Clip - 36905

DuraDrive 4-48HD and 4-30

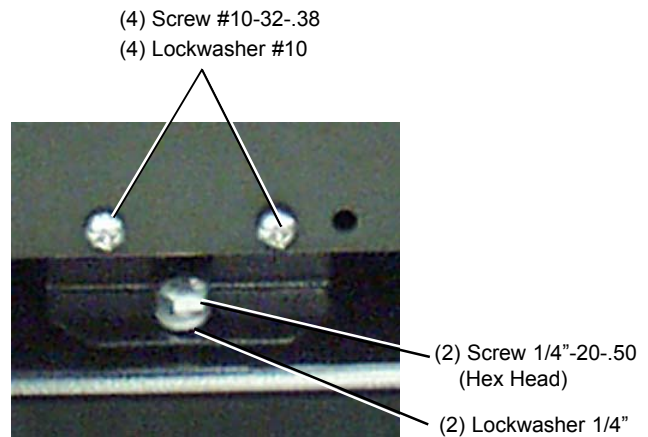

Note that 36905 clip fits under and behind the base of the wire feeder.

