

# ARCAIR®

AN ESAB® BRAND

SLICE® TORCH  
SLICE® PACKAGE  
SLICE® STRIKER

## SLICE® EXOTHERMIC CUTTING EQUIPMENT

SAFETY AND  
OPERATING  
INSTRUCTIONS

English  
French  
Spanish  
Italian

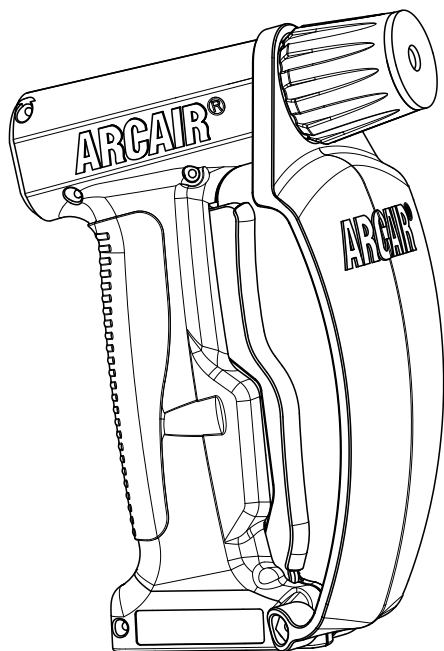

Art# A-13635



Revision: AB

Issue Date: 26-06-2018

Manual No.: 89250840



## **WE APPRECIATE YOUR BUSINESS!**

Congratulations on your new Arcair® product. We are proud to have you as our customer and will strive to provide you with the best service and support in the industry. This product is backed by our extensive warranty and world-wide service network. To locate your nearest distributor or service agency visit us on the web at [www.esab.com/arcair](http://www.esab.com/arcair).

This Manual has been designed to instruct you on the correct installation and use of your Arcair product. Your satisfaction with this product and its safe operation is our ultimate concern. Therefore, please take the time to read the entire manual, especially the Safety Precautions. They will help you to avoid potential hazards that may exist when working with this product.

## **YOU ARE IN GOOD COMPANY!**

The Brand of Choice for Contractors and Fabricators Worldwide.

Arcair is a Global Brand of cutting Products for ESAB. We manufacture and supply to major welding industry sectors worldwide including; Manufacturing, Construction, Mining, Automotive, Aerospace, Engineering, Rural and DIY/Hobbyist.

We distinguish ourselves from our competition through market-leading, dependable products that have stood the test of time. We pride ourselves on technical innovation, competitive prices, excellent delivery, superior customer service and technical support, together with excellence in sales and marketing expertise.

Above all, we are committed to develop technologically advanced products to achieve a safer working environment within the welding industry.



**WARNING**

Read and understand this entire Manual and your employer's safety practices before installing, operating, or servicing the equipment. While the information contained in this Manual represents the Manufacturer's best judgment, the Manufacturer assumes no liability for its use.

SLICE® Exothermic Cutting Equipment  
Safety and Operating Instructions  
Manual Number: 89250840

Published by:  
ESAB Group Inc.  
2800 Airport Rd.  
Denton, TX. 76208  
(940) 566-2000  
www.esab.com/arcair

U.S. Customer Care: (800) 426-1888  
International Customer Care: (940) 381-1212

Copyright © 2018 ESAB. All rights reserved.

Reproduction of this work, in whole or in part, without written permission of the publisher is prohibited.

The publisher does not assume and hereby disclaims any liability to any party for any loss or damage caused by any error or omission in this Manual, whether such error results from negligence, accident, or any other cause.

For Printing Material Specification in the Americas refer to document 47X1920  
For Printing Material Specification in Europe refer to document 47X1953  
Publication Date: 08-03-2018  
Revision Date: 26-06-2018

Record the following information for Warranty purposes:

Where Purchased: \_\_\_\_\_

Purchase Date: \_\_\_\_\_

**Be sure this information reaches the operator.  
You can get extra copies through your supplier.**

## **CAUTION**

**These INSTRUCTIONS are for experienced operators. If you are not fully familiar with the principles of operation and safe practices for arc welding and cutting equipment, we urge you to read our booklet, "Precautions and Safe Practices for Arc Welding, Cutting, and Gouging," Form 52-529. Do NOT permit untrained persons to install, operate, or maintain this equipment. Do NOT attempt to install or operate this equipment until you have read and fully understand these instructions. If you do not fully understand these instructions, contact your supplier for further information. Be sure to read the Safety Precautions before installing or operating this equipment.**

### **USER RESPONSIBILITY**

This equipment will perform in conformity with the description thereof contained in this manual and accompanying labels and/or inserts when installed, operated, maintained and repaired in accordance with the instructions provided. This equipment must be checked periodically. Malfunctioning or poorly maintained equipment should not be used. Parts that are broken, missing, worn, distorted or contaminated should be replaced immediately. Should such repair or replacement become necessary, the manufacturer recommends that a telephone or written request for service advice be made to the Authorized Distributor from whom it was purchased.

This equipment or any of its parts should not be altered without the prior written approval of the manufacturer. The user of this equipment shall have the sole responsibility for any malfunction which results from improper use, faulty maintenance, damage, improper repair or alteration by anyone other than the manufacturer or a service facility designated by the manufacturer.

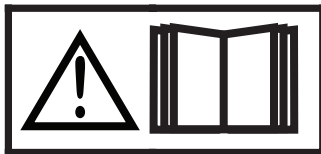

**READ AND UNDERSTAND THE INSTRUCTION MANUAL BEFORE INSTALLING OR  
OPERATING.  
PROTECT YOURSELF AND OTHERS!**

**ASSUREZ-VOUS QUE CE DOCUMENT D'INFORMATION EST DISTRIBUÉ À L'OPÉRATEUR.  
DES COPIES SUPPLÉMENTAIRES SONT DISPONIBLES CHEZ VOTRE FOURNISSEUR.**

## **MISE EN GARDE**

**Les INSTRUCTIONS suivantes sont destinées aux opérateurs qualifiés seulement. Si vous n'avez pas une connaissance approfondie des principes de fonctionnement et des règles de sécurité applicables au soudage à l'arc et à l'équipement de coupage, nous vous suggérons de lire notre brochure « Précautions et pratiques de sécurité pour le soudage à l'arc, le coupage et le gougeage », Formulaire 52-529. Ne permettez PAS aux personnes non qualifiées d'installer, d'utiliser ou d'effectuer des opérations de maintenance sur cet équipement cet équipement. Ne tentez PAS d'installer ou d'utiliser cet équipement avant d'avoir lu et bien compris ces instructions. Si vous ne comprenez pas bien les instructions, renseignez-vous auprès de votre fournisseur. Assurez-vous de lire les Règles de Sécurité avant d'installer ou d'utiliser cet équipement.**

### **RESPONSABILITÉS DE L'UTILISATEUR**

Cet équipement fonctionnera conformément à la description contenue dans ce manuel, les étiquettes d'accompagnement et/ou les feuillets d'information à condition d'être installé, utilisé, entretenu et réparé selon les instructions fournies. L'équipement doit être contrôlé de manière périodique. Ne jamais utiliser un équipement qui ne fonctionne correctement bien ou n'est pas bien entretenu. Les pièces qui sont brisées, usées, déformées ou contaminées doivent être remplacées immédiatement. Dans le cas où une réparation ou un remplacement est nécessaire, le fabricant recommande de faire une demande de conseil de service écrite ou par téléphone auprès du distributeur agréé où l'équipement a été acheté.

Cet équipement ou ses pièces ne doivent pas être modifiés sans permission préalable écrite du fabricant. L'utilisateur de l'équipement sera le seul responsable de toute défaillance résultant de toute utilisation, maintenance, réparation incorrectes, de dommages ou encore de modification apportées par une personne autre que le fabricant ou un centre de service désigné par ce dernier.

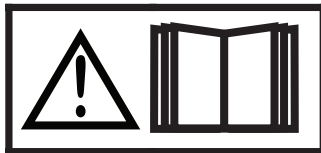

**ASSUREZ-VOUS DE LIRE ET DE COMPRENDRE LE MANUEL D'UTILISATION AVANT  
D'INSTALLER OU D'UTILISER L'UNITÉ.  
PROTÉGEZ-VOUS ET LES AUTRES!**



AN ESAB® BRAND

## DECLARATION OF CONFORMITY

According to

The Low Voltage Directive 2014/35/EU, entering into force 20 April 2016

The EMC Directive 2014/30/EU, entering into force 20 April 2016

The RoHS Directive 2011/65/EU, entering into force 2 January 2013

### Type of equipment

EXOTHERMIC CUTTING SYSTEM

### Type designation etc.

SLICE Exothermic Torch Cutting System

### Brand name or trade mark

Arcair SLICE

### Manufacturer or his authorised representative

#### Name, address, telephone No:

ESAB Group Inc.

2800 Airport Rd

Denton TX 76207

Phone: +01 800 426 1888, FAX +01 603 298 7402

### The following harmonised standard in force within the EEA has been used in the design:

IEC/EN 60974-11:2010 Arc Welding Equipment Part II: Electrode Holders

IEC/EN 60974-10:2014 + AMD 1:2015 Published 2015-06-19 Arc Welding Equipment - Part 10: Electromagnetic compatibility (EMC) requirements

*Additional Information: Restrictive use, Class A equipment, intended for use in location other than residential.*

**By signing this document, the undersigned declares as manufacturer, or the manufacturer's authorised representative, that the equipment in question complies with the safety requirements stated above.**

**Date**

15 September, 2016

**Signature**

Flavio Santos

**Position**

General Manager  
Accessories and Adjacencies

CE 2018

# Table of Contents

<b>SECTION 1: INTRODUCTION</b> .....	<b>1</b>
1.01 How to Use this Manual .....	1
1.02 Receipt of Equipment.....	1
1.03 Description .....	1
<b>SECTION 2: SAFETY PRECAUTIONS</b> .....	<b>2</b>
<b>SECTION 3: PROCESS FUNDAMENTALS</b> .....	<b>5</b>
<b>SECTION 4: EQUIPMENT</b> .....	<b>6</b>
4.01 SLICE Torch .....	6
4.02 SLICE Striker .....	6
4.03 SLICE Packs .....	6
4.04 Cutting Rods.....	7
4.05 SLICE Components .....	8
4.06 Charging the Ignition Source.....	9
<b>SECTION 5: CUTTING DATA</b> .....	<b>10</b>
5.01 Material Cutting Rates .....	10
5.02 Cutting Electrode Types .....	11
5.03 SLICE Cutting Torches.....	11
<b>SECTION 6: OPERATION</b> .....	<b>12</b>
6.01 Cutting without Power .....	12
6.02 Cutting with Power .....	13
6.03 Hole Piercing .....	14
6.04 Copper and Copper Alloys.....	15
<b>SECTION 7: IMPORTANT PROCESS VARIABLES</b> .....	<b>16</b>
7.01 Oxygen Pressure.....	16
7.02 Amperage.....	17
7.03 Travel Speed.....	17
7.04 Electrode-To-Work Angle .....	17
<b>SECTION 8: APPLICATIONS</b> .....	<b>18</b>
<b>SECTION 9: TROUBLESHOOTING</b> .....	<b>19</b>
9.01 General troubleshooting.....	19
9.02 Ignition source led display guide.....	20
<b>SECTION 10: PARTS LISTING</b> .....	<b>22</b>
<b>SECTION 11: STATEMENT OF WARRANTY</b> .....	<b>25</b>

This Page Intentionally Blank

# SECTION 1: INTRODUCTION

## 1.01 How to Use this Manual

To ensure safe operation, read the entire manual, including the chapter on safety instructions and warnings.

Throughout this manual, the words **WARNING**, **CAUTION**, and **NOTE** may appear. Pay particular attention to the information provided under these headings. These special annotations are easily recognized as follows:

**NOTE!**

An operation, procedure, or background information which requires additional emphasis or is helpful in efficient operation of the system.

**CAUTION**

A procedure which, if not properly followed, may cause damage to the equipment.

**WARNING**

A procedure which, if not properly followed, may cause injury to the operator or others in the operating area.

**WARNING**

Gives information regarding possible electrical shock injury. Warnings will be enclosed in a box such as this.

## 1.02 Receipt of Equipment

When you receive the equipment, check it against the invoice to make sure it is complete and inspect the equipment for possible damage due to shipping. If there is any damage, notify the carrier immediately to file a claim. Furnish complete information concerning damage claims or shipping errors to the location in your area, listed on the back cover of this manual. Include a full description of the parts in error.

If you want additional or replacement copies of this manual, please contact Arcair at the address and phone number in your area listed on the inside back cover of this manual. Include the Manual number (Page i).

## 1.03 Description

Arcair® SLICE® systems can cut, burn or pierce almost any metallic, non-metallic or composite material. The SLICE exothermic torch cuts right through hard-to-cut materials such as mild, stainless and alloy steels, cast iron, aluminum, magnesium and other non-ferrous metals, slag and refractory materials, and concrete or brick.

## **SECTION 2: SAFETY PRECAUTIONS**



**WARNING**

SERIOUS INJURY OR DEATH may result if welding and cutting equipment is not properly installed, used, and maintained. Misuse of this equipment and other unsafe practices can be hazardous. The operator, supervisor, and helper must read and understand the following safety warnings and instructions before installing or using any welding or cutting equipment, and be aware of the dangers of the welding or cutting process. Training and proper supervision are important for a safe work place. Keep these instructions for future use. Additional recommended safety and operating information is referenced in each section.



**WARNING**

This product contains chemicals, including lead, or otherwise produces chemicals known to the State of California to cause cancer, birth defects and other reproductive harm. Wash hands after handling.

### **ELECTRIC SHOCK CAN CAUSE INJURY OR DEATH**



The purchaser is responsible for the safe installation, operation, and use of all products purchased, including compliance with all applicable ISO standards and local codes in the country of use. Do not service or repair equipment with power on. Do not operate equipment with protective insulators or covers removed. Service or repair to equipment must be done by qualified and/or trained personnel only.

Do not contact electrically live parts. Always wear dry welding gloves that are in good condition. Aluminized, protective clothing can become part of the electrical path. Keep oxygen cylinders, chains, wires, ropes, cranes, and hoists away from any part of the electrical path. All ground connections must be checked periodically to determine if they are mechanically strong, and electrically adequate for the required current. When engaged in AC welding/cutting under wet conditions or where perspiration is a factor, the use of automatic controls for reducing the no load voltage is recommended to reduce shock hazards. Accidental contact must be prevented when using open circuit voltage exceeding 80 volts AC, or 100 volts DC by adequate insulation or other means. When welding is to be suspended for any length of time, such as during lunch or overnight, all electrode holders and electrodes should be removed from the electrode holder and the power supply should be turned off to prevent accidental contact. Keep MIG Guns, electrode holders, TIG torches, Plasma torches, and electrodes away from moisture and water. See safety and operating references 1, 2, and 8.

### **SMOKE, FUMES, AND GASES CAN BE DANGEROUS TO YOUR HEALTH**



Ventilation must be adequate to remove smoke, fumes, and gases during operation to protect operators and others in the area. Vapors of chlorinated solvents can form the toxic gas "Phosgene" when exposed to ultraviolet radiation from an electric arc. All solvents, degreasers, and potential sources of these vapors must be removed from the operating area. Use air-supplied respirators if ventilation is not adequate to remove all fumes and gases. Oxygen supports, and vigorously accelerates fire and should **never** be used for ventilation. **See safety and operating references 1, 2, 3, and 4.**

### ARC RAYS, HOT SLAG, AND SPARKS CAN INJURE EYES AND BURN SKIN

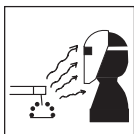

Welding and cutting processes produce extreme localized heat and strong ultraviolet rays. **Never** attempt to weld/cut without a federally compliant welding helmet with the proper lens. A number 12 to 14 shade filter lens provides the best protection against arc radiation. When in a confined area, prevent the reflected arc rays from entering around the helmet. Approved shielding curtains and appropriate goggles should be used to provide protection to others in the surrounding area. Skin should be protected from arc rays, heat, and molten metal. Always wear protective gloves and clothing. All pockets should be closed and cuffs sewn shut. Leather aprons, sleeves, leggings, etc. should be worn for out-of-position welding and cutting, or for heavy operations using large electrodes. Hightop work shoes provide adequate protection from foot burns. For added protection, use leather spats. Flammable hair preparations should not be used when welding/cutting. Wear ear plugs to protect ears from sparks. Where work permits, the operator should be enclosed in an individual booth painted with a low reflective material such as zinc oxide. **See safety and operating references 1, 2, and 3.**

### WELDING SPARKS CAN CAUSE FIRES AND EXPLOSIONS



Combustibles reached by the arc, flame, flying sparks, hot slag, and heated materials can cause fire and explosions. Remove combustibles from the work area and/or provide a fire watch. Avoid oily or greasy clothing as a spark may ignite them. Have a fire extinguisher nearby, and know how to use it. If welding/cutting is to be done on a metal wall, partition, ceiling, or roof, precautions must be taken to prevent ignition of nearby combustibles on the other side. Do not weld/cut containers that have held combustibles. All hollow spaces, cavities, and containers should be vented prior to welding/cutting to permit the escape of air or gases. Purging with inert gas is recommended. **Never** use oxygen in a welding torch. Use only inert gases or inert gas mixes as required by the process. Use of combustible compressed gases can cause explosions resulting in personal injury or death. Arcing against any compressed gas cylinder can cause cylinder damage or explosion. **See safety and operating references 1, 2, 5, 7, and 8.**

### **SAFETY AND OPERATING REFERENCES**

1. Code of Federal Regulations (OSHA) Section 29, Part 1910.95, 132, 133, 134, 139, 251, 252, 253, 254 and 1000. U.S. Government Printing Office, Washington, DC 20402.
2. ANSI Z49.1-2012 "Safety in Welding, Cutting, and Allied Processes".
3. ANSI Z87.1-2015 "American National Standard for Occupational and Educational Personal Eye and Face Protection Devices".
4. ANSI/ASSE Z88.2-2015 "American National Standard Practices for Respiratory Protection". American National Standards Institute Inc., 1430 Broadway, New York, NY 10018.
5. AWS F4.1:2017. "Safe Practices for the Preparation of Containers and Piping for Welding, Cutting, and Allied Processes"
6. AWS C5.3:2000 (R2011) "Recommended Practices For Air Carbon Arc Gouging And Cutting". American Welding Society, 8669 NW 36 Street, PO Box 130, Miami, Florida 33166-6672
7. NFPA 51B:2014 "Standard for Fire Prevention During Welding, Cutting, and Other Hot Work" National Fire Protection Association (NFPA), 1 Batterymarch Park, Quincy, Massachusetts, USA 02169-7471
8. NFPA-70:2017 "National Electrical Code". National Fire Protection Association (NFPA), 1 Batterymarch Park, Quincy, Massachusetts, USA 02169-7471
9. CAN/CSA-W117.2-12 (R2017) "Safety in Welding, Cutting and Allied Processes". Canadian Standards Association, 178 Rexdale Blvd., Rexdale, Ontario, Canada M9W 1R3.

---

## **SECTION 3: PROCESS FUNDAMENTALS**

---

The SLICE Exothermic Cutting process uses an exothermic chemical reaction that burns, melts or vaporizes most materials. The reaction begins with an electrical arc or alternate energy source that causes a steel cutting rod to burn. Oxygen flows through the center of the rod.

Because of the rod's design, the burning makes excess heat ("exo - thermic") which cuts the workpiece. Once started, the burn will continue as long as oxygen flows through the rod. The heat created melts the material being cut. The velocity of oxygen through the rod blows the molten material away, creating the kerf or cut line.

This arc ignition process led to invention of the oxy-arc torch and design of equipment for underwater construction and salvage.

The electrical arc that starts the burn can be from a welding power source that delivers at least 100 amps, a 12-volt lead acid or similar low-impedance battery. The cutting process can run without power, using the heat of the reaction only, or with power, cutting with an electrical arc from a welding power source providing more heat.

### **HISTORY**

The exothermic cutting rod is a small oxygen lance. A prime example of the combustion triangle is one side being fuel (the steel lance); the oxygen source (pure oxygen being forced through the lance); the heat of combustion (some external source of heat). However, when the lance pierces a slag puddle, the puddle becomes the source of heat until the lance is withdrawn, at which time burning stops.

In 1888, a published paper described passing oxygen through a steel tube and heating the tube to a bright red. Heat resulted. In 1901, Ernst Henner filed a German patent on an early oxygen lance made of two concentric tubes. In 1902, documentation shows that the oxygen lance replaced oil and gas torches for opening furnace taps in steel blast furnaces. The oxygen lance has since been used to cut rocks and concrete structures. An example is cutting up reinforced concrete structures such as bunker emplacements and tank traps built in Europe during World War II.

An ideal way to start the lance, workers found, was to use a welding power source on conductive material to strike an arc and start the burn. This process worked well in construction, even in mud and water.

Around 1940, the burning bar or exothermic lance was first marketed as a cutting tool. A flexible version made of an insulated cable was introduced around 1960. Not until the early 1980's were smaller burning bars designed for hand torch use, above and below water. A one-piece unit now allows for adequate rod surface exposure to an oxygen supply for exothermic cutting. Arcair, an ESAB brand, is a world leader in metal removal and cutting and sells this exothermic cutting equipment under the trade name Arcair SLICE.

## SECTION 4: EQUIPMENT

### 4.01 SLICE Torch

The SLICE Torch, a gun-shaped tool, provides a means of gripping the rod and supplying the oxygen and power to the cutting rod. The basic torch includes 10 ft. (3.05 m) of power cable and oxygen hose. The power cable can carry 200 amps in a power cutting operation. The oxygen hose includes a standard size oxygen fitting and is ready to be connected to the user's oxygen regulator. This standard torch has a flexible hand shield which is easily replaceable if damaged, plus the torch is molded from a super tough Thermo plastic.

An optional 6" (152 mm) collet extension and 6" (152 mm) diameter extension shield is available to help reduce torch wear or damage when piercing. Also available is a 3/8" (9.5 mm) adapter kit consisting of a collet chuck, Collet Nut, washer, and flashback arrestor needed to adapt the torch for using the 3/8" (9.5 mm) diameter cutting rods.

### 4.02 SLICE Striker

A SLICE Striker is available for cutting without power. The striker is an insulated piece of copper plate with a serrated surface. By scratching the rod against the copper plate an arc is initiated and the cutting process begins. Striker wear can be extended by using the smallest exposed portion of the copper plate and gradually increasing.

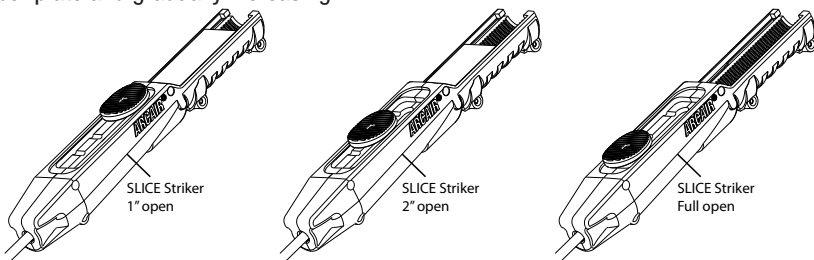

The SLICE striker comes standard with a 10 ft. (3.05 m) cable.

### 4.03 SLICE Packs

#### SLICE® Utility Pack

Includes a rugged carrying case. Power connections (12 volt battery only), tong style battery clamps makes power connection quick and easy. Industrial oxygen hose connected to the torch; industry standard Oxygen hose supplies the torch with oxygen and standard fittings used to connect to oxygen regulators.



#### SLICE® Battery Pack

Includes a rugged carrying case. Power connections twist-lock style connection; easy to connect to battery ignition source for both torch and striker and color coded connectors. Industrial oxygen hose connected to the torch; industry standard Oxygen hose supplies the torch with oxygen, standard fittings used to connect to oxygen regulators, and color coded connections.



**SLICE® Industrial Pack**

Versatility for industrial type applications. Industrial cart capable of carrying a 9" diameter oxygen cylinder. Packed with the basic items needed to do a cutting job; SLICE Torch Assembly - 10 ft leads, striker assembly, oxygen regulator, battery charger, and cutting rod holder. Industrial oxygen hose connected to the torch; industry standard Oxygen hose supplies the torch with oxygen and standard fittings used to connect to oxygen regulators.



**SLICE® Complete Pack**

Rugged aluminum carrying case; packed with the basic items needed to do a cutting job. Self-contained cutting system lends itself well to the emergency type cutting situations where seconds count. Complete unit weights 70 lbs (31.75 kg). Storage compartment with hinged door for parts storage during transportation. Power connections twist-lock style connection; easy to connect to battery ignition source assembly for both torch and striker and color coded connectors. Industrial oxygen hose connected to the torch; industry standard Oxygen hose supplies the torch with oxygen. Standard fittings used to connect to oxygen regulators.



**4.04 Cutting Rods**

SLICE Cutting Rods are made of carbon steel, by rolling a steel strip into a rod, and are coated or uncoated. The coating is made of arc stabilizers and a binder. Several advantages to using the coated rods with power include:

- More efficient cutting rates (more cut per inch of rod burnt and more cut per minute of burn time)
- Easier rod operation
- Protection from burning out on the side of the rod, especially when piercing

Rod Size	Uses
1/4" x 22" 6.4 mm x 558.8 mm	Standard size cutting rods used in a variety of jobs. Recommended for all straight-line cutting and most general-cutting applications. Coated or uncoated.
1/4" x 44" 6.4 mm x 1117.6 mm	Used when greater length is needed to reach the cutting area or when piercing holes in materials thicker than 18" (457,2 mm). Uncoated.
3/8" x 18" 9.5 mm x 457.2 mm	Used for heavy piercing with a large bore. Coated or uncoated.
3/8" x 36" 9.5 mm X 914.4 mm	Used when added length is needed to complete cutting. Uncoated.



**NOTE!**

All SLICE cutting torches come ready to use the 1/4" (6.4 mm) diameter rods. Use of the 3/8" (9.5 mm) diameter rods requires the 3/8" (9.5 mm) conversion kit, Part Number 94-463-032.

# 4.05 SLICE Components

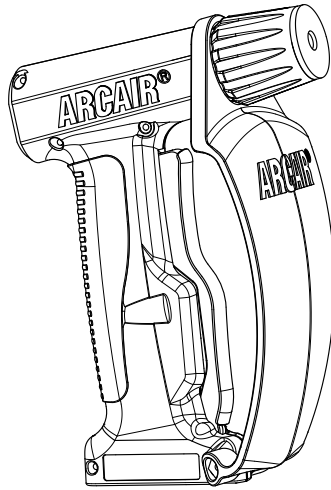

Art# A-13635

Figure 1: SLICE Torch

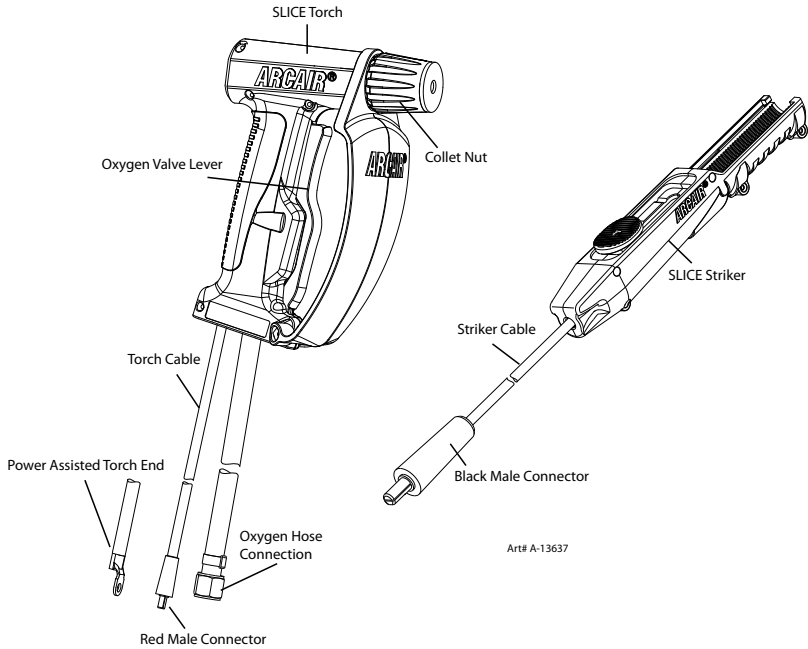

Art# A-13637

Figure 2: SLICE Torch and Striker

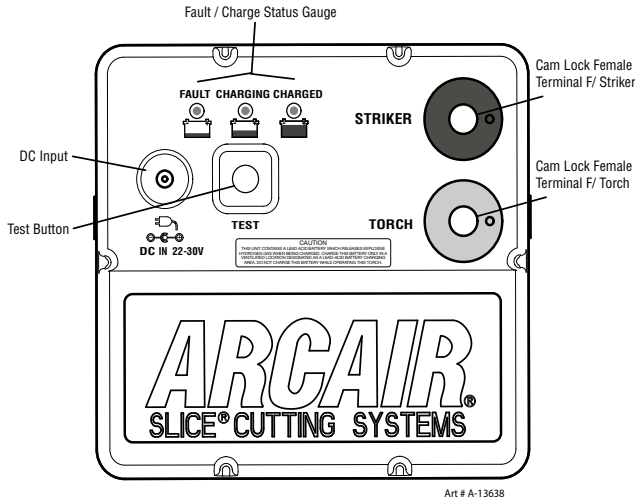

Figure 3: SLICE Battery Ignition Source

## 4.06 Charging the Ignition Source

There are 3 LEDs on the Ignition Source panel (FAULT, CHARGING, and CHARGED). Fully charged status will display all LEDs green. For explanation of LED readouts refer to Section 9.2 Ignition Source LED Display Guide. The AC/DC Power Adapter (p/n 96-076-043) is required to complete these steps.



### NOTE!

It is recommended that the unit be recharged after every use or whenever the Charge Status LEDs shows 50% or less.

Charging the Ignition Source:

1. Press the TEST button on the Ignition Source panel to check status. If the LEDs do not present all green LEDs then proceed with the steps below.
2. Insert the AC/DC Power Adapter Output connector into the DC Input socket on the Ignition Source panel and plug the Power Adapter input cord into a 120 V, 60Hz or 240 V 50Hz wall outlet.
3. Keep the unit plugged in until fully charged. Charging time can be between 2-5 hours. On the Ignition Source panel amber LEDs will display when fully charged.
4. Disconnect the AC/DC Power Adapter connector from the Ignition Source and push the Test button to confirm full charge status. All the LEDs will display green.

# SECTION 5: CUTTING DATA

The following chart helps determine the best settings for a specific use as a result of extensive laboratory testing of the SLICE Equipment to determine the best cutting rates. Actual cutting results obtained in the field vary due to conditions and experience of the user. Various usages of SLICE Equipment return various results. Adjust the settings for any use. Use the following chart as a guide.

Oxygen pressure of 80 psi (551.6 kPa) achieves the best cutting. Some operations may require higher or lower oxygen pressures - minimum 40 psi (275.8 kPa); maximum 100 psi (689.5 kPa). Amperage over 200 amps does not improve cutting speed.

Find the right metal and thickness. For composites or unlisted metals, locate the listed type that most resembles the material to be cut.



**NOTE!**

All these cutting values are based on 1/4" (6.4 mm) diameter flux-coated rods. Cutting rates with 1/4" (6.4 mm) bare rods are slightly less than the values listed in the chart.

## 5.01 Material Cutting Rates

Material Type	Material Thickness	Length of Cut per Inch Rod Used	Cutting Speed	
			in/min	cm/min
	<b>in(mm)</b>	<b>in(cm)</b>		
Carbon Steel	1/8 (3.2)	2.25 (5.7)	72	183
	1/4 (6.4)	1.5 (3.8)	52	132
	3/8 (9.5)	1.38 (3.5)	42	106
	1/2 (12.7)	1.25 (3.2)	35	89
	3/4 (19.1)	.75 (1.9)	22	56
Stainless	1/8 (3.2)	2.0 (5.1)	65	165
	1/4 (6.4)	1.13 (2.9)	36	91
Aluminum	1/4 (6.4)	1.75 (4.4)	58	147
	3/8 (9.5)	1.25 (3.2)	38	97
	3/4 (19.1)	.75 (1.9)	23	58

**SAMPLE SELECTIONS:**

**The approximate cut/inch rod x amount of cut per rod = cut per rod used**

**Data:** Cutting 3/8" (9.5 mm) aluminum with 1/4" (6.4 mm) fluxed rod

1.25" (3.2 cm) x 19" (48.3 cm) = 23.8" (60.5 cm). Approximate cut/min arc time = 38" (97 cm)

**Data:** Cutting 1/4" (6.4 mm) carbon steel with 1/4" fluxed rod

1.5" (3.8 cm) x 19" (48.3 cm) = 28.5" (72.4 cm). Approximate cut/min arc time = 52" (132 cm)

## 5.02 Cutting Electrode Types

Cutting rates in this chart were obtained using 80 PSI (551.6 kPa) oxygen pressure and 1/4" x 22" (6.4 mm x 559 mm) cutting rods. These rates are averaged values based on multiple cutting tests. Actual cutting rates may vary due to parameters used and operator expertise.

Part No.	Diameter in(mm)	Length in(mm)	Coated or Uncoated.	Package Quantity	Oxygen Flow Rate CFM(CMM)	Burn Time (sec)
42-049-002	1/4 (6.4)	22 (559)	Coated	25	7.5 (.21)	40-45
42-049-003	1/4 (6.4)	22 (559)	Coated	100	7.5 (.21)	40-45
43-049-002	1/4 (6.4)	22 (559)	Uncoated	25	7.5 (.21)	40-45
43-049-003	1/4 (6.4)	22 (559)	Uncoated	100	7.5 (.21)	40-45
43-049-005	1/4 (6.4)	44 (1117)	Uncoated	25	7.5 (.21)	80-90
42-049-005	3/8 (9.5)	18 (457)	Coated	50	12 (.34)	30-35
43-049-007	3/8 (9.5)	18 (457)	Uncoated	50	12 (.34)	30-35
43-049-009	3/8 (9.5)	36 (914)	Uncoated	25	12 (.34)	60-70

## 5.03 SLICE Cutting Torches

Part No.	Cable Size	Power Cable Length ft(m)	Oxygen Hose Length ft(m)	Cutting with Power	Cutting without Power
03-003-010	#1	10 (3.05)	10 (3.05)	Recommended	Can Be Used
03-003-011	#6			Limited Use Only	Recommended
03-003-012	#10			Not Recommended	Recommended

## SECTION 6: OPERATION

SLICE Exothermic Cutting uses heat from a chemical reaction between a consumable steel rod and oxygen flowing through the rod. Test data show that little or no oxygen remains. The oxygen not used in the reaction blows the molten material out of the cut area. This action creates the kerf that allows cut progression.

### 6.01 Cutting without Power

Cutting without power uses the heat reaction from the rod and the oxygen to cut. To initiate this type of cutting, ignite the rod from a spark supplied by a 12-volt battery or by a welding power source capable of delivering a 100-amp surge. Once this spark has ignited the rod, the electrical path is broken and the heat of the reaction melts the material and cuts it.

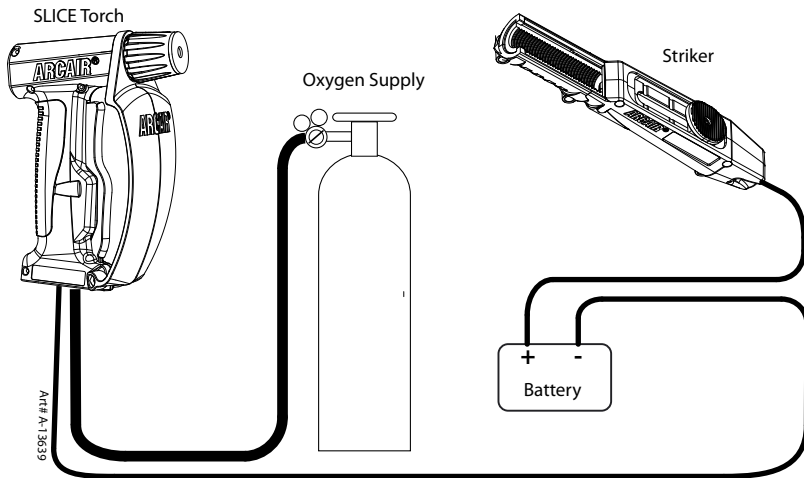

Figure 4: Cutting without Power

Cutting without power can be done in remote areas. Support equipment and bulky power sources are not needed.

1. Connect the torch to either terminal of a 12-volt battery or constant-current welding power source, then connect the striker or a strike plate to the other terminal. If using a welding power source, set output level for 100 amps.
2. Turn ON the oxygen supply and adjust the regulator to the proper working pressure. Insert the cutting rod into the collet and tighten the Collet Nut.
3. Tap the cutting rod on a hard, ungrounded surface to seat the rod in the torch.
4. Depress the torch oxygen valve lever and check for oxygen leaks around the Collet Nut.

**NOTE!**

If oxygen is leaking, repeat the procedure until no oxygen is leaking.

5. Put the torch in one hand and striker in the other. Depress the oxygen lever and touch the cutting rod to the striker.
6. Once the rod is ignited, remove the striker, then move the burning rod to the workpiece and begin cutting.

**NOTE!**

Hold the cutting rod at a  $45^\circ$  to  $80^\circ$  drag angle from the workpiece surface. The angle depends on the thickness and type of material being cut.

7. Make slight contact between the burning rod tip and the workpiece as the cut progresses. This placement requires two motions:
  - a. Inward towards the workpiece as the rod is consumed
  - b. In the direction of cut

Use a protective lens shade #5 since there is no electrical arc.

## 6.02 Cutting with Power

Cutting with power requires an electrical arc from a welding power supply and increases the heat created exothermically. Almost all constant-current welding power supplies can be used in powered exothermic cutting. Cutting with power is faster than cutting without power.

SLICE Torch

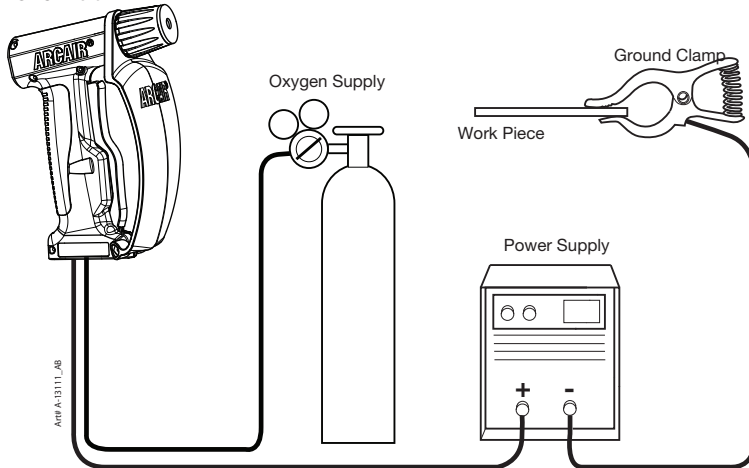

Figure 5: Cutting with Power



### CAUTION

Constant-voltage power supplies should not be used with exothermic cutting equipment. When the exothermic cutting rod contacts the workpiece, the power supply is dead shorted, causing maximum amperage output of the power supply. This surge can exceed the rated output of the machine and the recommended amperage for powered exothermic cutting.

1. Connect the torch to one terminal, then connect a welding ground clamp to the other terminal of a CC (Constant Current) welding power source.
2. Attach the ground clamp to the workpiece. Unlike other processes, this process uses either a welding power source set for DCEP (reverse polarity) or DCEN (straight polarity). AC (alternating current) power supplies can also be used without affecting cutting performance. **Do not** cut with power using a constant-potential power source.
3. Insert the cutting rod into the collet and tighten. Start the oxygen flow, touch the rod tip to the workpiece, and begin cutting. Hold the cutting rod at a 45° to 80° drag angle from the workpiece surface.
4. Depress the torch oxygen valve lever and check for oxygen leaks around the Collet Nut.
5. As the cut proceeds, make slight contact between the burning rod and the workpiece. This placement requires two motions:
  - a. Inward towards the workpiece as the rod is consumed
  - b. In the direction of cut

Use a protective lens shade #10 or higher to protect from arc flash.

## 6.03 Hole Piercing

Perform most piercing operations without power.

1. Remove the Collet Nut Assembly from the front of the torch and remove the brass collet, washer and spark arrestor from the torch.
2. Attach the Collet Extension Assembly to the front end of the torch and once tightened re-install the spark arrestor, washer and brass collet into the assembly.
3. Slide the Extension Shield over the Collet Extension Assembly until it bottoms out against the metal ring on the assembly.
4. Reinstall the Collet Nut Assembly onto the Collet Extension Assembly.
5. Insert the SLICE cutting rod into the torch and tighten the Collet Nut Assembly. Tap the SLICE rod against the work surface and tighten the Collet Nut again, this ensures the cutting rod is seated against the rubber washer.
6. Ignite the cutting rod as explained in the "Cutting without Power" section.
7. Move the burning rod to the pierce point and, with the rod angled away from the operator, begin piercing the hole.

8. Once the hole is under way, bring the cutting rod perpendicular to the surface of the workpiece. Keep the cutting rod deep enough in the hole to feel slight resistance from the non-molten material at the base of the hole. Use a slight circular motion while piercing the hole to keep the rod free of molten material coming out of the hole.
9. Move the rod in and out of the hole occasionally to maintain an open path for the molten material.

**CAUTION**

The molten material travels back up the rod while piercing. Wear proper clothing for protection from the molten spray. Hold the torch at arm's length to keep the operator as far away from the molten material as possible. An optional 6" (152.4 mm) collet extension and extension shield are available for the SLICE cutting torch to protect the operator and torch.

**NOTE!**

Piercing in the flat position is more difficult than piercing horizontally. Piercing flat progresses more slowly. For example, piercing a hole in a floor is more difficult and slower than piercing a hole in a wall.

## 6.04 Copper and Copper Alloys

**CUTTING** Because of the very rapid heat absorption of copper and its alloys, cut with power on these materials. Use a maximum of 300 amps since copper quickly absorbs the heat created from the exothermic reaction, reducing the effectiveness of the cutting process. Cutting with power releases more heat so it is possible to cut some copper pieces. The larger the size of the part the more difficult it is to cut. A sawing motion into the cut kerf speeds cutting. Brass, bronze and other alloys are slightly easier to cut, but these alloys should be cut using power, if possible.

**PIERCING** Use power when piercing copper and its alloys. This results in extremely fast rod consumption. The higher the copper content of the part, the harder the material is to cut.

# SECTION 7: IMPORTANT PROCESS VARIABLES

Exothermic cutting is easier than most cutting processes. Certain variables reduce the efficiency of this process, resulting in poor cutting. The most important variables are listed and discussed below.

## 7.01 Oxygen Pressure

Oxygen maintains the exothermic burn and removes the molten material from the cut. Eighty psi (551.6 kPa) yields the most efficient cutting rates (amount of cut per inch of rod burned) on materials up to 3" (76.2 mm) thick. Using pressures less than 80 psi (551.6 kPa) on such materials reduces cutting rates due to inadequate pressure to remove the molten material.

However, scarfing is most efficient using pressures under 80 psi (551.6 kPa). Lower pressures offer a more controllable scarfing action. With material thicker than 3" (76.2 mm), pressures over 80 psi (551.6 kPa) can be used to give the oxygen enough velocity to blow away molten material at the bottom of the cut. Using higher pressures on thicker materials causes a more forceful oxygen jet and faster rod consumption. A sawing motion at 80 psi (551.6 kPa) or a larger diameter rod may help cut these materials more efficiently.

When piercing, 80 psi (551.6 kPa) is the best pressure to use. To pierce, an operator should reduce the pressure slightly to control the distance the molten material travels. Once there is a hole, full pressure should be used.

The operator can vary pressure by using the torch's oxygen lever. When the thickness of the material - usually more than 12" (304.8 mm) - needs added pressure to blow the molten material out of a pierced hole, pressures above 80 psi (551.6 kPa) are used. This is the only exception.

The SLICE cutting process uses standard industrial-grade oxygen to support the exothermic reaction and to remove molten metal. All SLICE equipment uses standard oxygen fittings. SLICE torches are equipped with 10 ft. (3.05 m) of 1/4" (6.4 mm) I.D. oxygen hose. The usual operating pressure is 80 psi (551.6 kPa). Applications such as cutting material sections 3" (76.2 mm) and thicker might require higher operating pressures. Pressures as low as 40 psi (275.8 kPa) have been used to do jobs such as washing off rivet heads and scarfing out small cracks for repair.

The oxygen consumption rate for SLICE cutting rods at 80 psi (551.6 kPa) is 7 to 7.5 cfm (0.21 cmm) for the 1/4" (6.4 mm) diameter cutting rods and 12 to 13 cfm (0.34 to 0.37 cmm) for the 3/8" (95 mm) diameter cutting rods. This rate varies if a different operating pressure is used.

**WARNING**

**DO NOT** use compressed air for exothermic cutting. Compressed air does not contain enough oxygen to support the burn; therefore, impurities can damage or destroy the torch and components. The torch could burn from the inside or even explode from the buildup of dirt from the compressed air in the oxygen-supply tube and cause serious injury to the operator.

## **7.02 Amperage**

Electrical current increases the heat from the reaction in exothermic cutting, allowing faster cutting. 200 amps yields the most efficient cutting rates with power. When cutting with power and using less than 200 amps, the amount of cut per minute will be lower. Amperage above 200 amps consumes the rod faster, reducing the cut per inch of rod burned. Exothermic cutting equipment uses around 200 amps. Exceeding this amperage could cause equipment damage.

When cutting without power, current from the battery ignites the rod. To ignite the rod a surge of at least 100 amps is needed. If the battery has not been properly charged it will not have enough amperage to ignite the cutting rod.

## **7.03 Travel Speed**

The cutting rod burns constantly without an electrical arc. Therefore, cut as fast as possible without losing the cut kerf. If the travel speed is too fast, the material will not cut completely through and molten slag will be blown back from the workpiece.

## **7.04 Electrode-To-Work Angle**

The electrode-to-work angle is the most flexible process variable. However, use of an improper angle can cause reduced cutting efficiency. For most cutting jobs the ideal angle is between 45° and 80°. For thicker material, hold the rod closer to an 80° angle. The electrode-to-work angle is typically a drag angle - the rod is held so the tip of the burning rod is away from the direction of travel. Cutting sheet metal is one exception since it is usually faster and better controlled when the user keeps a 45° angle or slightly less, and pushes the rod in the direction of cut. Aluminum, regardless of its thickness, requires a 70° to 80° drag angle.

## SECTION 8: APPLICATIONS

Industry	Applications
Construction	Bridge repair. Cutting structural steel. Pierce and remove rivets and bolts without damaging surrounding material. Punch holes in concrete, crack rocks. Highway maintenance. Repair of highway guardrails. Cut reinforcing rods. Cut plaster or concrete insulated pipes. Repairs on heavy equipment. Removing old structural steel. Scrap clean up. Salvage work.
Plant Maintenance	Equipment/machinery repair. Remove headless bolts or frozen pins. Remove seized bearings. Plant renovation. Removing old piping systems. Punch lag holes to secure machinery. Repair machine bases. Remove old machinery. Cut up or repair storage tanks.
Heavy Equipment Maintenance	General maintenance (field or shop repairs). Repair buckets. Remove seized or worn pins. Cut worn or frayed control cables. Cut badly corroded material.
Foundry	Remove core sand trapped in holes of castings. Remove areas of imbedded sand. Cut gates, risers, fins from castings. Cut small multiple castings from runners. Cut through slag in furnace cleanup. Punch relief holes in molds. Cut up spilled materials for remelting. Cut up scrap castings. General plant maintenance.
Fire Service Rescue Departments	Rapid entry into buildings. Cut through steel doors, dead bolts, barred windows, overhead doors. Cut through debris (metal, concrete, plaster, rock) from building collapse. Rescue operations.
Police/Swat	Rapid entry into buildings. Cut through steel doors, dead bolts, barred windows, overhead doors. Rescue operations.
Railroad	Rail car repair and maintenance. Track maintenance/cut damaged sections of track. Repairs in remote yard locations. Remove old rail loading docks.
Mining	Equipment maintenance (field and shop repairs). Cut steel cables. Repair coal tipples. Belt repairs. Remove abandoned piping and railways. Piercing holes in rock to set blasting charges.
Metal Fabrication	Pierce starter holes in thick plates. Rough-cut pieces of material from large plates. Field construction.
Demolition	Cut through rebar. Pierce concrete. Remove rivets and frozen bolts. Cut steel imbedded in concrete. Equipment maintenance/repair. Cut corroded material.
Power Plants	General maintenance. Removal of piping. Cut out scrap feeder pans. Remove old grating covered with refractory. Remove old boilers. Remove or repair storage tanks.
Farming	General maintenance. Equipment/machinery repair. Repair stainless steel fertilizer tanks. Cut metal encrusted with rust and/or mud.
Scrap/Salvage Yards	Cut all types of scrap metal, including cast iron, stainless steel, and aluminum. Cut up scrap cars in remote areas of yard. Equipment maintenance. Cut badly corroded or crusted material.

## SECTION 9: TROUBLESHOOTING

### 9.01 General troubleshooting

Problem	Solution
Rod burns but with no cut progression.	<ol style="list-style-type: none"> <li>1. Too much gap between the burning rod tip and the workpiece. Must maintain slight pressure against workpiece.</li> <li>2. Travel speed too slow.</li> <li>3. Oxygen pressure too low.</li> </ol>
Molten material not being blown out of cut area.	<ol style="list-style-type: none"> <li>1. Insufficient oxygen pressure being used.</li> <li>2. Rubber washer behind collet chuck worn and needs to be replaced.</li> <li>3. Travel speed too fast.</li> </ol>
Battery will only start a few rods before charge is depleted.	<ol style="list-style-type: none"> <li>1. Battery was not given sufficient time to recharge.</li> <li>2. Battery needs to be replaced.</li> <li>3. Battery left exposed to subfreezing temperatures.</li> </ol>
Torch shield is being burnt off around Collet Nut.	<ol style="list-style-type: none"> <li>1. Rod is not properly seated in torch. Refer to Section 6 on operating techniques to properly seat rod.</li> <li>2. Collet extension not used when piercing holes.</li> </ol>
When piercing anything but copper and its alloys, the rod consumes extremely fast.	<ol style="list-style-type: none"> <li>1. Operator is piercing with power. All piercing operations except ones on copper and its alloys should be done without power.</li> </ol>
Arced collet chuck and/or rod is burned off just outside of collet chuck.	<ol style="list-style-type: none"> <li>1. Using a CC type welding power source.</li> </ol>

**9.02 IGNITION SOURCE LED DISPLAY GUIDE**

<b>Condition #</b>	<b>Charger Connected</b>	<b>Test Button</b>	<b>Left LED</b>	<b>Center LED</b>	<b>Right LED</b>	
1	No	Un-pressed	Off	Off	Off	
2	Yes	Un-pressed	Off	Off	Off	
3	Yes	Un-pressed	Off	Amber	Amber	
4	Yes	Un-pressed	Off	Amber	Off	
5	Yes	Un-pressed	Off	Off	Amber	
6	Yes	Un-pressed	Red	Off	Off	
7	Yes	Un-pressed	Red (Flash)	Off	Off	
8	No	Pressed	Off	Off	Off	
9	No	Pressed	Off	Green	Off	
10	No	Pressed	Green	Off	Off	
11	No	Pressed	Green	Green	Green	
12	Yes	Pressed	Off	Off	Off	
13	Yes	Pressed	Green	Off	Off	
14	Yes	Pressed	Off	Green	Off	
9	Yes	Pressed	Green	Green	Green	

Condition	Action
Standby	None
Wall power disconnected / Internal electronics fault	Verify electrical outlet is energized. Verify AC/DC Power Adapter Output connector is fully inserted into DC Input socket. Return unit for repair.
Analyzing battery (30 seconds)	Wait 30 seconds for charge status. New LED configuration will appear.
Charging battery	Wait up to 2-5 hours for a fully discharged battery.
Battery fully charged / Trickle mode	Disconnect charger and store or keep charger connected or use unit.
Thermal fuse tripped / Battery fault / Battery missing	Disconnect charger and wait 10 minutes for fuse to reset / Replace battery / Return unit for repair
Battery temperature high	Wait for unit to cool down / Move to cooler location
Battery <20% capacity	Unit not recommended for use / Connect charger
Battery 20% to 60% capacity	Unit needs charging / Can be operated / Connect charger
Battery 60% to 80% capacity	Connect charger / Unit ready for use
Battery >80% capacity	Unit ready for use
Battery <20% capacity	None
Battery 20% to 60% capacity	None
Battery 60% to 80% capacity	None
Battery >80% capacity	Disconnect Charger / Unit ready for use

# SECTION 10: PARTS LISTING

## SLICE STRIKER REPLACEMENT PARTS

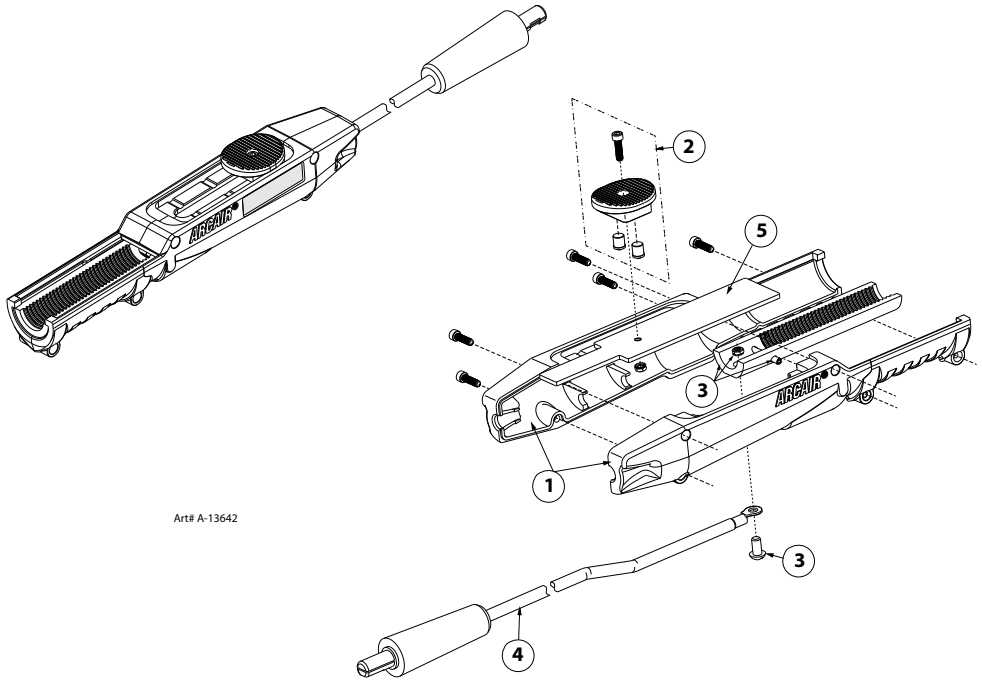

Art# A-13642

Item No.	Part No.	Description
1	94-370-198	Handle Halves - LH / RH
2	94-370-202	SLICE Striker Slider Knob
3	96-070-033	Striker Bar
4	96-130-320	Cable Assembly
5	96-070-034	Striker Shield

**BATTERY IGNITION SOURCE**

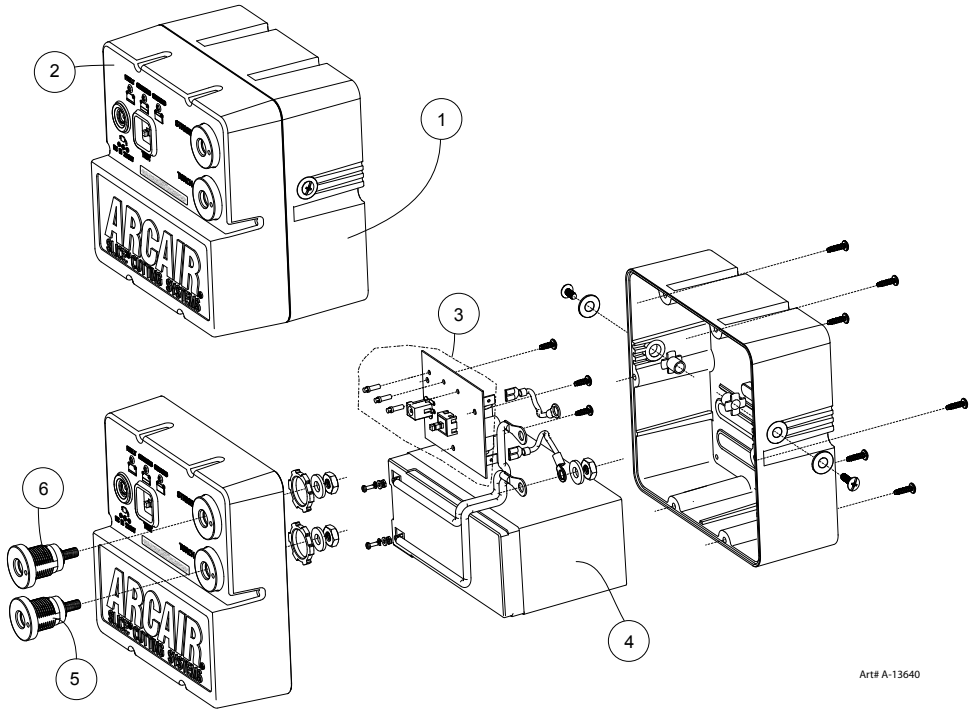

Art# A-13640

Item No.	Part No.	Description
1	94-134-038	Battery Pack Case Back Half
2	94-134-039	Battery Pack Case Front Half
3	96-162-758	Circuit Board Assembly
4	96-076-018	Battery Assembly
5	96-169-374	Red Female Panel Receptacle
6	96-169-375	Black Female Panel Receptacle

**SLICE TORCH REPLACEMENT PARTS**

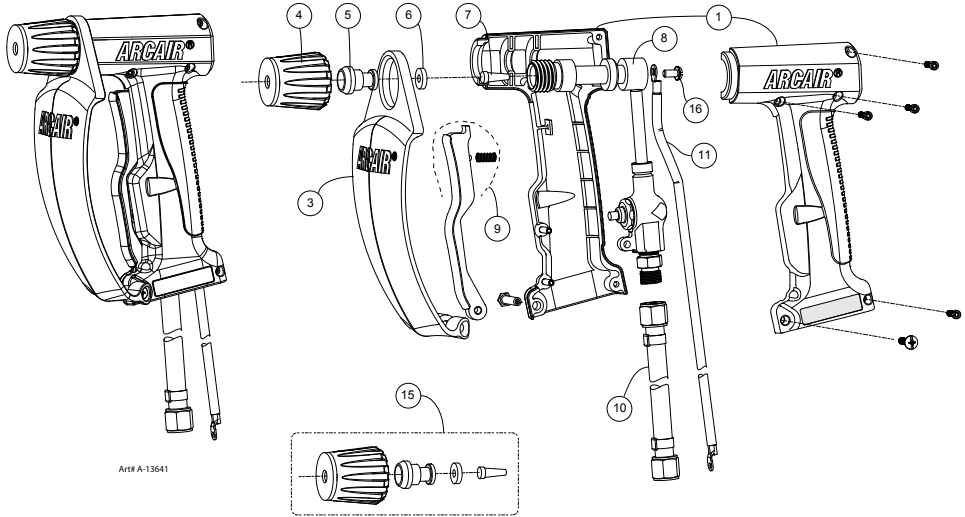

Item No.	Part No.	Description
1	94-370-197	SLICE Handle - RH & LH (w/screws)
3	94-777-112	Shield
4	94-168-022	1/4" Collet Nut Assembly
	95-168-024	3/8" Collet Nut Assembly
5	94-158-048	1/4" Collet Chuck
	94-158-045	3/8" Collet Chuck
6	94-940-109	Washer
7	94-305-009	Flashback Arrestor
8	94-378-338	Head/Body Assembly
9	94-476-086	Lever Assembly
10	94-396-193	Oxygen Hose - 10 ft. (3m)
11	96-130-279	Cable Assembly for SLICE Torch Part No. 03-003-010
	96-130-276	Cable Assembly (Utility & Industrial Pack)
	96-130-319	Cable Assembly (Battery & Complete Pack)

---

## **SECTION 11: STATEMENT OF WARRANTY**

---

**LIMITED WARRANTY:** Arcair, an ESAB brand, warrants that its products will be free of defects in workmanship or material. Should any failure to conform to this warranty appear within the time period applicable to the Arcair products as stated below, Arcair shall, upon notification thereof and substantiation that the product has been stored, installed, operated, and maintained in accordance with Arcair's specifications, instructions, recommendations and recognized standard industry practice, and not subject to misuse, repair, neglect, alteration, or accident, correct such defects by suitable repair or replacement, at Arcair's sole option, of any components or parts of the product determined by Arcair to be defective.

**THIS WARRANTY IS EXCLUSIVE AND IS IN LIEU OF ALL OTHER WARRANTIES, EXPRESS OR IMPLIED, INCLUDING ANY WARRANTY OF MERCHANTABILITY OR FITNESS FOR A PARTICULAR PURPOSE.**

**LIMITATION OF LIABILITY:** Arcair, an ESAB brand, shall not under any circumstances be liable for special or consequential damages, such as, but not limited to, damage or loss of purchased or replacement goods, or claims of customers of distributor (hereinafter the "Purchaser") for service interruption. The remedies of the Purchaser set forth herein are exclusive and the liability of Arcair with respect to any contract, or anything done in connection therewith such as the performance or breach thereof, or from the manufacture, sale, delivery, resale, or use of any goods covered by or furnished by Arcair whether arising out of contract, negligence, strict tort, or under any warranty, or otherwise, shall not, except as expressly provided herein, exceed the price of the goods upon which such liability is based.

**THIS WARRANTY BECOMES INVALID IF REPLACEMENT PARTS OR ACCESSORIES ARE USED WHICH MAY IMPAIR THE SAFETY OR PERFORMANCE OF ANY ARCAIR PRODUCT.**

**THIS WARRANTY IS INVALID IF THE PRODUCT IS SOLD BY NON-AUTHORIZED PERSONS.**

This warranty is effective for the time stated in the Warranty Schedule beginning on the date that the authorized distributor delivers the products to the Purchaser.

Warranty repairs or replacement claims under this limited warranty must be submitted by an authorized Arcair repair facility within thirty (30) days of the repair. No transportation costs of any kind will be paid under this warranty. Transportation charges to send products to an authorized warranty repair facility shall be the responsibility of the Purchaser. All returned goods shall be at the Purchaser's risk and expense. This warranty supersedes all previous Arcair warranties.

# ESAB subsidiaries and representative offices

## Europe

### AUSTRIA

ESAB Ges.m.b.H  
Vienna-Liesing  
Tel: +43 1 888 25 11  
Fax: +43 1 888 25 11 85

### BELGIUM

S.A. ESAB N.V.  
Heist-op-den-Berg  
Tel: +32 70 233 075  
Fax: +32 15 257 944

### BULGARIA

ESAB Kft Representative Office  
Sofia  
Tel/Fax: +359 2 974 42 88

### THE CZECH REPUBLIC

ESAB VAMBERK s.r.o.  
Vamberk  
Tel: +420 2 819 40 885  
Fax: +420 2 819 40 120

### DENMARK

Aktieselskabet ESAB  
Herlev  
Tel: +45 36 30 01 11  
Fax: +45 36 30 40 03

### FINLAND

ESAB Oy  
Helsinki  
Tel: +358 9 547 761  
Fax: +358 9 547 77 71

### FRANCE

ESAB France S.A.  
Cergy Pontoise  
Tel: +33 1 30 75 55 00  
Fax: +33 1 30 75 55 24

### GERMANY

ESAB Welding & Cutting  
GmbHZweigstelle  
Langerfeld  
Tel.: +49 2173 3945 0  
Fax.: +49 2173 3945 218

### GREAT BRITAIN

ESAB Group (UK) Ltd  
Waltham Cross  
Tel: +44 1992 76 85 15  
Fax: +44 1992 71 58 03  
ESAB Automation Ltd  
Andover  
Tel: +44 1264 33 22 33  
Fax: +44 1264 33 20 74

### HUNGARY

ESAB Kft  
Budapest  
Tel: +36 1 20 44 182  
Fax: +36 1 20 44 186

### ITALY

ESAB Saldatura S.p.A.  
Bareggio (Mi)  
Tel: +39 02 97 96 8.1  
Fax: +39 02 97 96 87 01

### THE NETHERLANDS

ESAB Nederland B.V.  
Amersfoort  
Tel: +31 33 422 35 55  
Fax: +31 33 422 35 44

## NORWAY

AS ESAB  
Larvik  
Tel: +47 33 12 10 00  
Fax: +47 33 11 52 03

## POLAND

ESAB Sp.zo.o.  
Katowice  
Tel: +48 32 351 11 00  
Fax: +48 32 351 11 20

## PORTUGAL

ESAB Lda  
Lisbon  
Tel: +351 8 310 960  
Fax: +351 1 859 1277

## ROMANIA

ESAB Romania Trading SRL  
Bucharest  
Tel: +40 316 900 600  
Fax: +40 316 900 601

## RUSSIA

LLC ESAB  
Moscow  
Tel: +7 (495) 663 20 08  
Fax: +7 (495) 663 20 09

## SLOVAKIA

ESAB Slovakia s.r.o.  
Bratislava  
Tel: +421 7 44 88 24 26  
Fax: +421 7 44 88 87 41

## SPAIN

ESAB Ibérica S.A.  
San Fernando de Henares  
Tel: +34 91 878 3600  
Fax: +34 91 802 3461

## SWEDEN

ESAB Sverige AB  
Gothenburg  
Tel: +46 31 50 95 00  
Fax: +46 31 50 92 22  
ESAB international AB  
Gothenburg  
Tel: +46 31 50 90 00  
Fax: +46 31 50 93 60

## SWITZERLAND

ESAB AG  
Baar  
Tel.: +41 44 741 25 25  
Fax.: +41 44 740 30 55

## UKRAINE

ESAB Ukraine LLC  
Kiev  
Tel: +38 (044) 501 23 24  
Fax: +38 (044) 575 21 88

## North and South America

### ARGENTINA

CONARCO  
Buenos Aires  
Tel: +54 11 4 753 4039  
Fax: +54 11 4 753 6313

### BRAZIL

ESAB S.A.  
Contagem-MG  
Tel: +55 31 2191 4333  
Fax: +55 31 2191 4440

### CANADA

ESAB Group Canada Inc.  
Mississauga, Ontario  
Tel: +1 905 670 02 20  
Fax: +1 905 670 48 79

### MEXICO

ESAB Mexico S.A.  
Monterrey  
Tel: +52 8 350 5559  
Fax: +52 8 350 7554

### USA

ESAB Welding & Cutting  
Products  
Florence, SC  
Tel: +1 843 669 44 11  
Fax: +1 843 664 57 48

## Asia/Pacific

### AUSTRALIA

ESAB South Pacific  
Archerfield BC QLD 4108  
Tel: +61 1300 372 228  
Fax: +61 7 3711 2328

### CHINA

Shanghai ESAB A/P  
Shanghai  
Tel: +86 21 2326 3000  
Fax: +86 21 6566 6622

### INDIA

ESAB India Ltd  
Calcutta  
Tel: +91 33 478 45 17  
Fax: +91 33 468 18 80

### INDONESIA

P.T. ESABindo Pratama  
Jakarta  
Tel: +62 21 460 0188  
Fax: +62 21 461 2929

### JAPAN

ESAB Japan  
Tokyo  
Tel: +81 45 670 7073  
Fax: +81 45 670 7001

### MALAYSIA

ESAB (Malaysia) Snd Bhd  
USJ  
Tel: +603 8023 7835  
Fax: +603 8023 0225

### SINGAPORE

ESAB Asia/Pacific Pte Ltd  
Singapore  
Tel: +65 6861 43 22  
Fax: +65 6861 31 95

## SOUTH KOREA

ESAB SeAH Corporation  
Kyungnam  
Tel: +82 55 269 8170  
Fax: +82 55 289 8864

## UNITED ARAB EMIRATES

ESAB Middle East FZE  
Dubai  
Tel: +971 4 887 21 11  
Fax: +971 4 887 22 63

## Africa

### EGYPT

ESAB Egypt  
Dokki-Cairo  
Tel: +20 2 390 96 69  
Fax: +20 2 393 32 13

### SOUTH AFRICA

ESAB Africa Welding & Cutting  
Ltd  
Durbanville 7570 - Cape Town  
Tel: +27 (0)21 975 8924

## Distributors

For addresses and phone numbers to our distributors in other countries, please visit our home page  
[www.esab.eu](http://www.esab.eu)



[www.esab.com](http://www.esab.com)

©2015 Welding and Cutting Products