

# PAK 300i PLASMA CUTTING SYSTEM

## Operating Manual

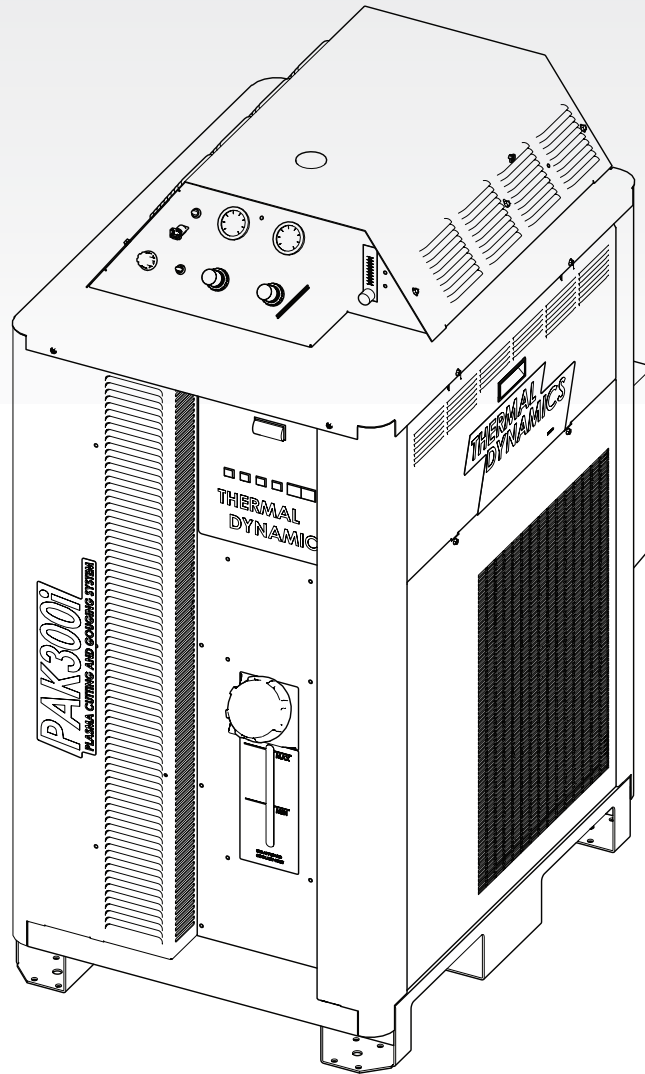

Art # H-0111

Revision: AC

Issue Date: 10, September 2024

Manual No.: 0-5714

## **WE APPRECIATE YOUR BUSINESS!**

Congratulations on your new Thermal Dynamics product. We are proud to have you as our customer and will strive to provide you with the best service and reliability in the industry. This product is backed by our extensive warranty and world-wide service network. To locate your nearest distributor or service agency call 1-800-752-7622, or visit us on the web at **www.thermal-dynamics.com**.

This Operating Manual has been designed to instruct you on the correct use and operation of your Thermal Dynamics product. Your satisfaction with this product and its safe operation is our ultimate concern. Therefore please take the time to read the entire manual, especially the Safety Precautions. They will help you to avoid potential hazards that may exist when working with this product.

## **YOU ARE IN GOOD COMPANY!**

**The Brand of Choice for Contractors and Fabricators Worldwide.**

Thermal Dynamics is a Global Brand of manual and automation Plasma Cutting Products.

We distinguish ourselves from our competition through market-leading, dependable products that have stood the test of time. We pride ourselves on technical innovation, competitive prices, excellent delivery, superior customer service and technical support, together with excellence in sales and marketing expertise.

Above all, we are committed to developing technologically advanced products to achieve a safer working environment within the welding industry



**WARNING**

Read and understand this entire Manual and your employer's safety practices before installing, operating, or servicing the equipment. While the information contained in this Manual represents the Manufacturer's best judgement, the Manufacturer assumes no liability for its use.

Plasma Cutting Power Supply, PAK 300i  
Operating Manual No. 0-5714

Published by:  
Thermal Dynamics Corporation.  
2800 Airport Rd.  
Denton, Texas 76207

[www.thermal-dynamics.com](http://www.thermal-dynamics.com)

© Copyright 2023 by  
Thermal Dynamics Corporation.

All rights reserved.

Reproduction of this work, in whole or in part, without written permission of the publisher is prohibited.

The publisher does not assume and hereby disclaims any liability to any party for any loss or damage caused by any error or omission in this Manual, whether such error results from negligence, accident, or any other cause.

For Printing Material Specification refer to document 47x1966.

Publication Date: 01, July 2024  
Revision Date: 10, September 2024

**Record the following information for Warranty purposes:**

Where Purchased: \_\_\_\_\_

Purchase Date: \_\_\_\_\_

Power Supply Serial #: \_\_\_\_\_

Torch Serial #: \_\_\_\_\_

**Be sure this information reaches the operator.  
You can get extra copies through your supplier.**

## **CAUTION**

**These INSTRUCTIONS are for experienced operators. If you are not fully familiar with the principles of operation and safe practices for arc welding and cutting equipment, we urge you to read our booklet, "Precautions and Safe Practices for Arc Welding, Cutting, and Gouging," Booklet 0-5407. Do NOT permit untrained persons to install, operate, or maintain this equipment. Do NOT attempt to install or operate this equipment until you have read and fully understand these instructions. If you do not fully understand these instructions, contact your supplier for further information. Be sure to read the Safety Precautions before installing or operating this equipment.**

### **USER RESPONSIBILITY**

This equipment will perform in conformity with the description thereof contained in this manual and accompanying labels and/or inserts when installed, operated, maintained and repaired in accordance with the instructions provided. This equipment must be checked periodically. Malfunctioning or poorly maintained equipment should not be used. Parts that are broken, missing, worn, distorted or contaminated should be replaced immediately. Should such repair or replacement become necessary, the manufacturer recommends that a telephone or written request for service advice be made to the Authorized Distributor from whom it was purchased.

This equipment or any of its parts should not be altered without the prior written approval of the manufacturer. The user of this equipment shall have the sole responsibility for any malfunction which results from improper use, faulty maintenance, damage, improper repair or alteration by anyone other than the manufacturer or a service facility designated by the manufacturer.

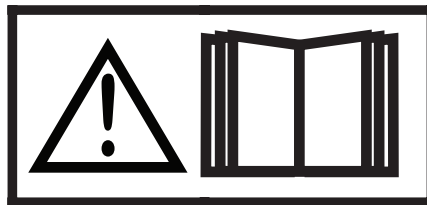

**READ AND UNDERSTAND THE INSTRUCTION MANUAL BEFORE INSTALLING OR OPERATING.  
PROTECT YOURSELF AND OTHERS!**

**ASSUREZ-VOUS QUE CETTE INFORMATION EST DISTRIBUÉE À L'OPÉRATEUR.  
VOUS POUVEZ OBTENIR DES COPIES SUPPLÉMENTAIRES CHEZ VOTRE FOURNISSEUR.**

## **MISE EN GARDE**

**Les INSTRUCTIONS suivantes sont destinées aux opérateurs qualifiés seulement. Si vous n'avez pas une connaissance approfondie des principes de fonctionnement et des règles de sécurité pour le soudage à l'arc et l'équipement de coupage, nous vous suggérons de lire notre brochure « Precautions and Safe Practices for Arc Welding, Cutting and Gouging, » Brochure 0-5407. Ne permettez PAS aux personnes non qualifiées d'installer, d'opérer ou de faire l'entretien de cet équipement. Ne tentez PAS d'installer ou d'opérer cet équipement avant de lire et de bien comprendre ces instructions. Si vous ne comprenez pas bien les instructions, communiquez avec votre fournisseur pour plus de renseignements. Assurez-vous de lire les Règles de Sécurité avant d'installer ou d'opérer cet équipement.**

## **RESPONSABILITÉS DE L'UTILISATEUR**

Cet équipement opérera conformément à la description contenue dans ce manuel, les étiquettes d'accompagnement et/ou les feuillets d'information si l'équipement est installé, opéré, entretenu et réparé selon les instructions fournies. Vous devez faire une vérification périodique de l'équipement. Ne jamais utiliser un équipement qui ne fonctionne pas bien ou n'est pas bien entretenu. Les pièces qui sont brisées, usées, déformées ou contaminées doivent être remplacées immédiatement. Dans le cas où une réparation ou un remplacement est nécessaire, il est recommandé par le fabricant de faire une demande de conseil de service écrite ou par téléphone chez le Distributeur Autorisé de votre équipement.

Cet équipement ou ses pièces ne doivent pas être modifiés sans permission préalable écrite par le fabricant. L'utilisateur de l'équipement sera le seul responsable de toute défaillance résultant d'une utilisation incorrecte, un entretien fautif, des dommages, une réparation incorrecte ou une modification par une personne autre que le fabricant ou un centre de service désigné par le fabricant.

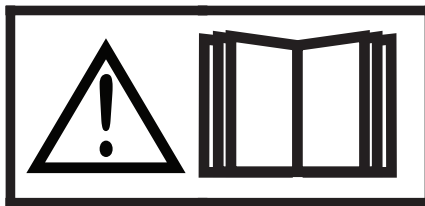

**ASSUREZ-VOUS DE LIRE ET DE COMPRENDRE LE MANUEL D'UTILISATION AVANT  
D'INSTALLER OU D'OPÉRER L'UNITÉ.**

**PROTÉGEZ-VOUS ET LES AUTRES!**

This Page Intentionally Blank



## DECLARATION OF CONFORMITY

According to

The Low Voltage Directive 2014/35/EU, entering into force 20 April 2016

The EMC Directive 2014/30/EU, entering into force 20 April 2016

The RoHS Directive 2011/65/EC, entering into force 2 January 2013

### Type of equipment

PLASMA CUTTING POWER SUPPLY

### Type designation etc.

PAK 300i, from serial number MX2425XXXXXX

### Brand name or trade mark

Thermal Dynamics

### Manufacturer or his authorised representative established within the EEA

#### Name, address, telephone No:

Thermal Dynamics  
2800 Airport Rd  
Denton TX 76207  
Phone: +01 800 426 1888, FAX +01 603 298 7402

### The following harmonised standard in force within the EEA has been used in the design:

*IEC/EN 60974-1:2017 / AMD1:2019 Arc Welding Equipment - Part 1: Welding power sources.  
IEC/EN 60974-10:2014 / AMD1:2015 Published 2015-06-19 Arc Welding Equipment - Part 10: Electromagnetic compatibility (EMC) requirements*

*Additional Information: Restrictive use, Class A equipment, intended for use in location other than residential.*

**By signing this document, the undersigned declares as manufacturer, or the manufacturer's authorised representative established within the EEA, that the equipment in question complies with the safety requirements stated above.**

**Date**

31 July 2024

**Signature**

John Boisvert

**Position**

Vice President  
Global Cutting  
Mechanized Cutting

CE 2024

This Page Intentionally Blank

## TABLE OF CONTENTS

<b>SECTION 1: SAFETY .....</b>	<b>11</b>
1.01 Safety Precautions - ENGLISH.....	11
1.02 Précautions de sécurité - FRENCH CANADIAN .....	16
<b>SECTION 2: SPECIFICATIONS .....</b>	<b>21</b>
2.01 General Description Of The System.....	21
2.02 Plasma Power Supply .....	21
2.03 Plasma Cutting Torch.....	21
2.04 System Component Layout.....	21
2.05 Power Supply Specifications & Electrical Requirements.....	22
2.06 Power Supply Dimensions.....	23
2.07 Power Supply Rear Panel Features.....	24
2.08 Gas Requirements.....	25
2.09 Gas Applications.....	25
2.10 PT-26P Torch Specifications .....	26
2.11 Maximum Manual PT-26P Speeds .....	28
<b>SECTION 3: INSTALLATION.....</b>	<b>31</b>
3.01 Installation Requirements.....	31
3.02 Cables and Leads Identification.....	32
3.03 Cables & Leads Identification.....	33
3.04 Position the Power Supply.....	34
3.05 Connect Input Power and Ground Cables .....	35
3.06 Connect Work Cable to Power Supply.....	36
3.07 Connect Gas and Coolant Supply Lines.....	37
3.08 Cables for Remote Control and Torch .....	38
3.09 Set Switches on the Command - Control Module.....	39
3.10 Connect Torch Leads to the Arc Starter .....	41
3.11 Fill Cooling System .....	43
<b>SECTION 4: OPERATION.....</b>	<b>45</b>
4.01 Power Supply Indicators.....	45
4.02 Control Console Features.....	46
4.03 System Operation .....	47
4.04 Gas Selection .....	49
4.05 Power Supply Status Codes.....	50
<b>SECTION 5: MAINTENANCE .....</b>	<b>57</b>
5.01 General Maintenance .....	57
5.02 Coolant Filter Cleaning Procedure.....	57
5.03 Coolant Replacement Procedure .....	58
5.04 Arc Starter Service .....	59
5.05 Arc Starter Spark Gap Adjustment.....	60
<b>SECTION 6: REPLACEMENT ASSEMBLIES &amp; PARTS .....</b>	<b>61</b>
6.01 Replacement Power Supply .....	61
6.02 Leads and Cables .....	61
6.03 Power Supply External Replacement Parts .....	63
6.04 Power Supply Replacement Parts - Lower Right Side.....	64
6.05 Power Supply Replacement Parts - Upper Right Side .....	65
6.06 Power Supply Replacement Parts - Left Side .....	66

## TABLE OF CONTENTS

6.07	Power Supply Replacement Parts RAS - GCM 1000 XT.....	67
6.08	Power Supply Replacement Parts - Rear Panel.....	68
6.09	Power Supply Replacement Parts - Front of GCM1000 XT.....	69
6.10	Recommended Gas Supply Hose.....	70
<b>APPENDIX 1: CNC CONTROL MODULE .....</b>		<b>71</b>
	Control PCB Connections.....	71
	Remote functions .....	72
	Remote Connections.....	73
<b>APPENDIX 2: CCM CPU PCB LAYOUT .....</b>		<b>74</b>
<b>APPENDIX 3: CCM I/O PCB LAYOUT .....</b>		<b>76</b>
<b>APPENDIX 4: PILOT PCB LAYOUT .....</b>		<b>78</b>
<b>APPENDIX 5: RELAY AND INTERFACE PCB LAYOUT .....</b>		<b>80</b>
<b>APPENDIX 6: DISPLAY PCB LAYOUT .....</b>		<b>82</b>
<b>APPENDIX 7: SYSTEM BIAS PCB LAYOUT .....</b>		<b>84</b>
<b>APPENDIX 8: MAIN INVERTER PCB LAYOUT .....</b>		<b>86</b>
<b>APPENDIX 9: CONTROL AND FAULT PCB LAYOUT .....</b>		<b>87</b>
<b>APPENDIX 10: CAP BIAS PCB LAYOUT.....</b>		<b>89</b>
<b>APPENDIX 11: SUPPRESSOR PCB LAYOUT.....</b>		<b>90</b>
<b>APPENDIX 12: COOLING DIAGRAM .....</b>		<b>91</b>
<b>APPENDIX 13: SYSTEM SCHEMATIC NON CE PG1 .....</b>		<b>93</b>
<b>APPENDIX 14: SYSTEM SCHEMATIC NON CE PG 2 .....</b>		<b>94</b>
<b>APPENDIX 15: SYSTEM SCHEMATIC CE PG 1 .....</b>		<b>96</b>
<b>APPENDIX 16: SYSTEM SCHEMATIC CE PG2 .....</b>		<b>98</b>
<b>APPENDIX 17: INVERTER SCHEMATIC.....</b>		<b>100</b>
<b>APPENDIX 18: GAS CONTROL &amp; ARC STARTER .....</b>		<b>102</b>
<b>APPENDIX 19: ADVANCED TROUBLESHOOTING .....</b>		<b>104</b>
<b>STATEMENT OF WARRANTY .....</b>		<b>139</b>

## SECTION 1: SAFETY

### 1.01 Safety Precautions - ENGLISH



**WARNING:** These Safety Precautions are for your protection. They summarize precautionary information from the references listed in Additional Safety Information section. Before performing any installation or operating procedures, be sure to read and follow the safety precautions listed below as well as all other manuals, material safety data sheets, labels, etc. Failure to observe Safety Precautions can result in injury or death.



**PROTECT YOURSELF AND OTHERS** -- Some welding, cutting, and gouging processes are noisy and require ear protection. The arc, like the sun, emits ultraviolet (UV) and other radiation and can injure skin and eyes. Hot metal can cause burns. Training in the proper use of the processes and equipment is essential to prevent accidents. Therefore:

Always wear safety glasses with side shields in any work area, even if welding helmets, face shields, and goggles are also required.

Use a face shield fitted with the correct filter and cover plates to protect your eyes, face, neck, and ears from sparks and rays of the arc when operating or observing operations. Warn bystanders not to watch the arc and not to expose themselves to the rays of the electric-arc or hot metal.

Wear flameproof gauntlet type gloves, heavy long-sleeve shirt, cuffless trousers, high-topped shoes, and a welding helmet or cap for hair protection, to protect against arc rays and hot sparks or hot metal. A flameproof apron may also be desirable as protection against radiated heat and sparks.

Hot sparks or metal can lodge in rolled up sleeves, trouser cuffs, or pockets. Sleeves and collars should be kept buttoned, and open pockets eliminated from the front of clothing.

Protect other personnel from arc rays and hot sparks with a suitable non-flammable partition or curtains.

Use goggles over safety glasses when chipping slag or grinding. Chipped slag may be hot and can fly far. Bystanders should also wear goggles over safety glasses.



**FIRES AND EXPLOSIONS** -- Heat from flames and arcs can start fires. Hot slag or sparks can also cause fires and explosions. Therefore:

Remove all combustible materials well away from the work area or cover the materials with a protective non-flammable covering. Combustible materials include wood, cloth, sawdust, liquid and gas fuels, solvents, paints and coatings, paper, etc.

Hot sparks or hot metal can fall through cracks or crevices in floors or wall openings and cause a hidden smoldering fire or fires on the floor below. Make certain that such openings are protected from hot sparks and metal."

Do not weld, cut or perform other hot work until the work piece has been completely cleaned so that there are no substances on the work piece which might produce flammable or toxic vapors. Do not do hot work on closed containers. They may explode.

Have fire extinguishing equipment handy for instant use, such as a garden hose, water pail, sand bucket, or portable fire extinguisher. Be sure you are trained in its use.

Do not use equipment beyond its ratings. For example, overloaded welding cable can overheat and create a fire hazard.

After completing operations, inspect the work area to make certain there are no hot sparks or hot metal which could cause a later fire. Use fire watchers when necessary.

For additional information, refer to NFPA Standard 51B, "Fire Prevention in Use of Cutting and Welding Processes", available from the National Fire Protection Association, Battery march Park, Quincy, MA 02269.



**NOISE** -- Noise can cause permanent hearing loss. Plasma arc processes can cause noise levels to exceed safe limits. You must protect your ears from loud noise to prevent permanent loss of hearing.

To protect your hearing from loud noise, wear protective ear plugs and/or ear muffs. Protect others in the workplace.

Noise levels should be measured to be sure the decibels (sound) do not exceed safe levels.

For information on how to test for noise, see "OSHA, SAFETY AND HEALTH STANDARDS, 29CFR 1910, obtainable from the Superintendent of Documents, U.S. Government Printing Office, Washington, D.C. 20402."



**ELECTRICAL SHOCK** -- Contact with live electrical parts and ground can cause severe injury or death. DO NOT use AC welding current in damp areas, if movement is confined, or if there is danger of falling.

Be sure the power source frame (chassis) is connected to the ground system of the input power.

Connect the work piece to a good electrical ground.

Connect the work cable to the work piece. A poor or missing connection can expose you or others to a fatal shock.

Use well-maintained equipment. Replace worn or damaged cables.

Keep everything dry, including clothing, work area, cables, torch/electrode holder, and power source.

Make sure that all parts of your body are insulated from work and from ground.

Do not stand directly on metal or the earth while working in tight quarters or a damp area; stand on dry boards or an insulating platform and wear rubber-soled shoes.

Put on dry, hole-free gloves before turning on the power.

Turn off the power before removing your gloves.

Refer to ANSI/ASC Standard Z49.1 (listed on next page) for specific grounding recommendations. Do not mistake the work lead for a ground cable.



**ELECTRIC AND MAGNETIC FIELDS** — May be dangerous. Electric current flowing through any conductor causes localized Electric and Magnetic Fields (EMF). Welding and cutting current creates EMF around welding cables and welding machines. Therefore:

Welders having pacemakers should consult their physician before welding. EMF may interfere with some pacemakers.

Exposure to EMF may have other health effects which are unknown.

Welders should use the following procedures to minimize exposure to EMF:

- A. Route the electrode and work cables together. Secure them with tape when possible.
- B. Never coil the torch or work cable around your body.
- C. Do not place your body between the torch and work cables. Route cables on the same side of your body.
- D. Connect the work cable to the work piece as close as possible to the area being welded.
- E. Keep welding power source and cables as far away from your body as possible.



**FUMES AND GASES** -- Fumes and gases, can cause discomfort or harm, particularly in confined spaces. Do not breathe fumes and gases. Shielding gases can cause asphyxiation.

Therefore:

Always provide adequate ventilation in the work area by natural or mechanical means. Do not weld, cut, or gouge on materials such as galvanized steel, stainless steel, copper, zinc, lead, beryllium, or cadmium unless positive mechanical ventilation is provided. Do not breathe fumes from these materials.

Do not operate near degreasing and spraying operations. The heat or arc rays can react with chlorinated hydrocarbon vapors to form phosgene, a highly toxic gas, and other irritant gases.

If you develop momentary eye, nose, or throat irritation while operating, this is an indication that ventilation is not adequate. Stop work and take necessary steps to improve ventilation in the work area. Do not continue to operate if physical discomfort persists.

Refer to ANSI/ASC Standard Z49.1 (see listing below) for specific ventilation recommendations.

**WARNING:** This product contains chemicals, including lead, known to the State of California to cause birth defects and other reproductive harm. Wash hands after handling.



**CYLINDER HANDLING** -- Cylinders, if mishandled, can rupture and violently release gas. Sudden rupture of cylinder, valve, or relief device can injure or kill. Therefore:

Use the proper gas for the process and use the proper pressure reducing regulator designed to operate from the compressed gas cylinder. Do not use adaptors. Maintain hoses and fittings in good condition. Follow manufacturer's operating instructions for mounting regulator to a compressed gas cylinder.

Always secure cylinders in an upright position by chain or strap to suitable hand trucks, undercarriages, benches, walls, post, or racks. Never secure cylinders to work tables or fixtures where they may become part of an electrical circuit.

When not in use, keep cylinder valves closed. Have valve protection cap in place if regulator is not connected. Secure and move cylinders by using suitable hand trucks. Avoid rough handling of cylinders.

Locate cylinders away from heat, sparks, and flames. Never strike an arc on a cylinder.

For additional information, refer to CGA Standard P-1, "Precautions for Safe Handling of Compressed Gases in Cylinders", which is available from Compressed Gas Association, 1235 Jefferson Davis Highway, Arlington, VA 22202.



**EQUIPMENT MAINTENANCE** -- Faulty or improperly maintained equipment can cause injury or death. Therefore:

Always have qualified personnel perform the installation, troubleshooting, and maintenance work. Do not perform any electrical work unless you are qualified to perform such work.

Before performing any maintenance work inside a power source, disconnect the power source from the incoming electrical power.

Maintain cables, grounding wire, connections, power cord, and power supply in safe working order. Do not operate any equipment in faulty condition.

Do not abuse any equipment or accessories. Keep equipment away from heat sources such as furnaces, wet conditions such as water puddles, oil or grease, corrosive atmospheres and inclement weather.

Keep all safety devices and cabinet covers in position and in good repair.

Use equipment only for its intended purpose. Do not modify it in any manner.



**ADDITIONAL SAFETY INFORMATION** -- For more information on safe practices for electric arc welding and cutting equipment, ask your supplier for a copy of "Precautions and Safe Practices for Arc Welding, Cutting and Gouging", Form 52-529.

The following publications, which are available from the American Welding Society, 550 N.W. LeJuene Road, Miami, FL 33126, are recommended to you:

ANSI/ASC Z49.1 - "Safety in Welding and Cutting".

AWS C5.1 - "Recommended Practices for Plasma Arc Welding".

AWS C5.2 - "Recommended Practices for Plasma Arc Cutting".

AWS C5.3 - "Recommended Practices for Air Carbon Arc Gouging and Cutting".

AWS C5.5 - "Recommended Practices for Gas Tungsten Arc Welding".

AWS C5.6 - "Recommended Practices for Gas Metal Arc Welding".

AWS SP - "Safe Practices" - Reprint, Welding Handbook.

ANSI/AWS F4.1, "Recommended Safe Practices for Welding and Cutting of Containers That Have Held Hazardous Substances."

CSA Standard - W117.2 = Safety in Welding, Cutting and Allied Processes.



Meaning of symbols - As used throughout this manual: Means Attention! Be Alert! Your safety is involved.

## DANGER

Means immediate hazards which, if not avoided, will result in immediate, serious personal injury or loss of life.

## CAUTION

Means potential hazards which could result in personal injury or loss of life.

## WARNING

Means hazards which could result in minor personal injury.

### Enclosure Class

The IP code indicates the enclosure class, i.e. the degree of protection against penetration by solid objects or water. Protection is provided against touch with a finger, penetration of solid objects greater than 12mm and against spraying water up to 60 degrees from vertical. Equipment marked IP21S may be stored, but is not intended to be used outside during precipitation unless sheltered.

## CAUTION

This product is solely intended for plasma cutting. Any other use may result in personal injury and / or equipment damage.

## CAUTION

If equipment is placed on a surface that slopes more than 15°, toppling over may occur. Personal injury and / or significant damage to equipment is possible.

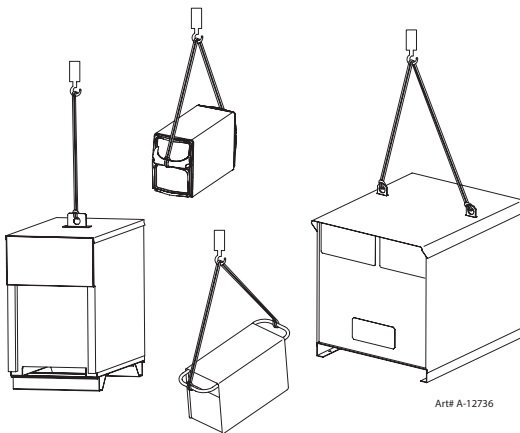
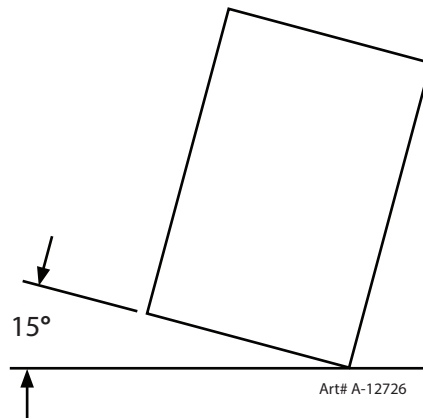

## CAUTION

To avoid personal injury and/or equipment damage, lift using method and attachment points shown here.

This Page Intentionally Blank

## 1.02 Précautions de sécurité - FRENCH CANADIAN



**AVERTISSEMENT :** Ces règles de sécurité ont pour but d'assurer votre protection. Ils récapitulent les informations de précaution provenant des références dans la section des Informations de sécurité supplémentaires. Avant de procéder à l'installation ou d'utiliser l'unité, assurez-vous de lire et de suivre les précautions de sécurité ci-dessous, dans les manuels, les fiches d'information sur la sécurité du matériel et sur les étiquettes, etc. Tout défaut d'observer ces précautions de sécurité peut entraîner des blessures graves ou mortelles.



**PROTÉGEZ-VOUS** -- Les processus de soudage, de coupage et de gougeage produisent un niveau de bruit élevé et exige l'emploi d'une protection auditive. L'arc, tout comme le soleil, émet des rayons ultraviolets en plus d'autre rayons qui peuvent causer des blessures à la peau et les yeux. Le métal incandescent peut causer des brûlures. Une formation reliée à l'usage des processus et de l'équipement est essentielle pour prévenir les accidents. Par conséquent:

Portez des lunettes protectrices munies d'écrans latéraux lorsque vous êtes dans l'aire de travail, même si vous devez porter un casque de soudeur, un écran facial ou des lunettes étanches.

Portez un écran facial muni de verres filtrants et de plaques protectrices appropriées afin de protéger vos yeux, votre visage, votre cou et vos oreilles des étincelles et des rayons de l'arc lors d'une opération ou lorsque vous observez une opération. Avertissez les personnes se trouvant à proximité de ne pas regarder l'arc et de ne pas s'exposer aux rayons de l'arc électrique ou le métal incandescent.

Portez des gants ignifugés à crispin, une chemise épaisse à manches longues, des pantalons sans rebord et des chaussures montantes afin de vous protéger des rayons de l'arc, des étincelles et du métal incandescent, en plus d'un casque de soudeur ou casquette pour protéger vos cheveux. Il est également recommandé de porter un tablier ininflammable afin de vous protéger des étincelles et de la chaleur par rayonnement.

Les étincelles et les projections de métal incandescent risquent de se loger dans les manches retroussées, les rebords de pantalons ou les poches. Il est recommandé de garder boutonnés le col et les manches et de porter des vêtements sans poches en avant.

Protégez toute personne se trouvant à proximité des étincelles et des rayons de l'arc à l'aide d'un rideau ou d'une cloison ininflammable.

Portez des lunettes étanches par dessus vos lunettes de sécurité lors des opérations d'écaillage ou de meulage du laitier. Les écailles de laitier incandescent peuvent être projetées à des distances considérables. Les personnes se trouvant à proximité doivent également porter des lunettes étanches par dessus leur lunettes de sécurité.



**INCENDIES ET EXPLOSIONS** -- La chaleur provenant des flammes ou de l'arc peut provoquer un incendie. Le laitier incandescent ou les étincelles peuvent également provoquer un incendie ou une explosion. Par conséquent :

Éloignez suffisamment tous les matériaux combustibles de l'aire de travail et recouvrez les matériaux avec un revêtement protecteur ininflammable. Les matériaux combustibles incluent le bois, les vêtements, la sciure, le gaz et les liquides combustibles, les solvants, les peintures et les revêtements, le papier, etc.

Les étincelles et les projections de métal incandescent peuvent tomber dans les fissures dans les planchers ou dans les ouvertures des murs et déclencher un incendie couvant à l'étage inférieur. Assurez-vous que ces ouvertures sont bien protégées des étincelles et du métal incandescent.

N'exécutez pas de soudure, de coupe ou autre travail à chaud avant d'avoir complètement nettoyé la surface de la pièce à traiter de façon à ce qu'il n'ait aucune substance présente qui pourrait produire des vapeurs inflammables ou toxiques. N'exécutez pas de travail à chaud sur des contenants fermés car ces derniers pourraient exploser.

Assurez-vous qu'un équipement d'extinction d'incendie est disponible et prêt à servir, tel qu'un tuyau d'arrosage, un seau d'eau, un seau de sable ou un extincteur portatif. Assurez-vous d'être bien instruit par rapport à l'usage de cet équipement.

Assurez-vous de ne pas excéder la capacité de l'équipement. Par exemple, un câble de soudage surchargé peut surchauffer et provoquer un incendie.

Une fois les opérations terminées, inspectez l'aire de travail pour assurer qu'aucune étincelle ou projection de métal incandescent ne risque de provoquer un incendie ultérieurement. Employez des guetteurs d'incendie au besoin.

Pour obtenir des informations supplémentaires, consultez le NFPA Standard 51B, "Fire Prevention in Use of Cutting and Welding Processes", disponible au National Fire Protection Association, Batterymarch Park, Quincy, MA 02269.



**BRUIT** -- Le bruit peut provoquer une perte permanente de l'ouïe. Les procédés de soudage à l'arc de plasma peuvent provoquer des niveaux sonores supérieurs aux limites normalement acceptables. Vous devez vous protéger les oreilles contre les bruits forts afin d'éviter une perte permanente de l'ouïe.

Pour protéger votre ouïe contre les bruits forts, portez des tampons protecteurs et/ou des protections auriculaires. Protégez également les autres personnes se trouvant sur le lieu de travail.

Il faut mesurer les niveaux sonores afin d'assurer que les décibels (le bruit) ne dépassent pas les niveaux sûrs.

Pour plus d'informations sur la manière de tester le bruit, voir «OSHA, SAFETY AND HEALTH STANDARDS, 29CFR 1910, disponible auprès du Superintendent of Documents, U.S. Government Printing Office, Washington, D.C. 20402».



**CHOC ÉLECTRIQUE** -- Le contact avec des pièces électriques ou les pièces de mise à la terre sous tension peut causer des blessures graves ou mortelles. NE PAS utiliser un courant de soudage c.a. dans un endroit humide, en espace restreint ou si un danger de chute se pose.

Assurez-vous que le châssis de la source d'alimentation est branché au système de mise à la terre de l'alimentation d'entrée.

Branchez la pièce à traiter à une bonne mise de terre électrique.

Branchez le câble de masse à la pièce à traiter et assurez une bonne connexion afin d'éviter le risque de choc électrique mortel.

Utilisez toujours un équipement correctement entretenu. Remplacez les câbles usés ou endommagés.

Veillez à garder votre environnement sec, incluant les vêtements, l'aire de travail, les câbles, le porteélectrode/torche et la source d'alimentation.

Assurez-vous que tout votre corps est bien isolé de la pièce à traiter et des pièces de la mise à la terre.

Si vous devez effectuer votre travail dans un espace restreint ou humide, ne tenez vous pas directement sur le métal ou sur la terre; tenez-vous sur des planches sèches ou une plate-forme isolée et portez des chaussures à semelles de caoutchouc.

Avant de mettre l'équipement sous tension, isolez vos mains avec des gants secs et sans trous.

Mettez l'équipement hors tension avant d'enlever vos gants.

Consultez ANSI/ASC Standard Z49.1 (listé à la page suivante) pour des recommandations spécifiques concernant les procédures de mise à la terre. Ne pas confondre le câble de masse avec le câble de mise à la terre.



**CHAMPS ÉLECTRIQUES ET MAGNÉTIQUES** — comportent un risque de danger. Le courant électrique qui passe dans n'importe quel conducteur produit des champs électriques et magnétiques localisés. Le soudage et le courant de coupage créent des champs électriques et magnétiques autour des câbles de soudage et l'équipement. Par conséquent :

Un soudeur ayant un stimulateur cardiaque doit consulter son médecin avant d'entreprendre une opération de soudage. Les champs électriques et magnétiques peuvent causer des ennuis pour certains stimulateurs cardiaques.

L'exposition à des champs électriques et magnétiques peut avoir des effets néfastes inconnus pour la santé.

Les soudeurs doivent suivre les procédures suivantes pour minimiser l'exposition aux champs électriques et magnétiques :

- A. Acheminez l'électrode et les câbles de masse ensemble. Fixez-les à l'aide d'une bande adhésive lorsque possible.
- B. Ne jamais enrouler la torche ou le câble de masse autour de votre corps.
- C. Ne jamais vous placer entre la torche et les câbles de masse. Acheminez tous les câbles sur le même côté de votre corps.
- D. Branchez le câble de masse à la pièce à traiter le plus près possible de la section à souder.

- E. Veillez à garder la source d'alimentation pour le soudage et les câbles à une distance appropriée de votre corps.



**LES VAPEURS ET LES GAZ** -- peuvent causer un malaise ou des dommages corporels, plus particulièrement dans les espaces restreints. Ne respirez pas les vapeurs et les gaz. Le gaz de protection risque de causer l'asphyxie.

Par conséquent :

Assurez en permanence une ventilation adéquate dans l'aire de travail en maintenant une ventilation naturelle ou à l'aide de moyens mécanique. N'effectuez jamais de travaux de soudage, de coupage ou de gougeage sur des matériaux tels que l'acier galvanisé, l'acier inoxydable, le cuivre, le zinc, le plomb, le beryllium ou le cadmium en l'absence de moyens mécaniques de ventilation efficaces. Ne respirez pas les vapeurs de ces matériaux.

N'effectuez jamais de travaux à proximité d'une opération de dégraissage ou de pulvérisation. Lorsque la chaleur ou le rayonnement de l'arc entre en contact avec les vapeurs d'hydrocarbure chloré, ceci peut déclencher la formation de phosgène ou d'autres gaz irritants, tous extrêmement toxiques.

Une irritation momentanée des yeux, du nez ou de la gorge au cours d'une opération indique que la ventilation n'est pas adéquate. Cessez votre travail afin de prendre les mesures nécessaires pour améliorer la ventilation dans l'aire de travail. Ne poursuivez pas l'opération si le malaise persiste.

Consultez ANSI/ASC Standard Z49.1 (à la page suivante) pour des recommandations spécifiques concernant la ventilation.

**AVERTISSEMENT** : Ce produit contient des produits chimiques, notamment du plomb, reconnu par l'État de la Californie pour causer des malformations congénitales et d'autres dommages touchant le système reproductif. **Se laver les mains après manipulation.**



**MANIPULATION DES CYLINDRES** -- La manipulation d'un cylindre, sans observer les précautions nécessaires, peut produire des fissures et un échappement dangereux des gaz. Une brisure soudaine du cylindre, de la soupape ou du dispositif de surpression peut causer des blessures graves ou mortelles. Par conséquent :

Utilisez toujours le gaz prévu pour une opération et le détendeur approprié conçu pour utilisation sur les cylindres de gaz comprimé. N'utilisez jamais d'adaptateur. Maintenez en bon état les tuyaux et les raccords. Observez les instructions d'opération du fabricant pour assembler le détendeur sur un cylindre de gaz comprimé.

Fixez les cylindres dans une position verticale, à l'aide d'une chaîne ou une sangle, sur un chariot manuel, un châssis de roulement, un banc, un mur, une colonne ou un support convenable. Ne fixez jamais un cylindre à un poste de travail ou toute autre dispositif faisant partie d'un circuit électrique.

Lorsque les cylindres ne servent pas, gardez les soupapes fermées. Si le détendeur n'est pas branché, assurez-vous que le bouchon de protection de la soupape est bien en place. Fixez et déplacez les cylindres à l'aide d'un chariot manuel approprié. Toujours manipuler les cylindres avec soin.

Placez les cylindres à une distance appropriée de toute source de chaleur, des étincelles et des flammes. Ne jamais amorcer l'arc sur un cylindre.

Pour de l'information supplémentaire, consultez CGA Standard P-1, "Precautions for Safe Handling of Compressed Gases in Cylinders", mis à votre disposition par le Compressed Gas Association, 1235 Jefferson Davis Highway, Arlington, VA 22202.



**ENTRETIEN DE L'ÉQUIPEMENT** -- Un équipement entretenu de façon défectueuse ou inadéquate peut causer des blessures graves ou mortelles. Par conséquent :

Efforcez-vous de toujours confier les tâches d'installation, de dépannage et d'entretien à un personnel qualifié. N'effectuez aucune réparation électrique à moins d'être qualifié à cet effet.

Avant de procéder à une tâche d'entretien à l'intérieur de la source d'alimentation, débranchez l'alimentation électrique.

Maintenez les câbles, les fils de mise à la terre, les branchements, le cordon d'alimentation et la source d'alimentation en bon état. N'utilisez jamais un équipement s'il présente une défectuosité quelconque.

N'utilisez pas l'équipement de façon abusive. Gardez l'équipement à l'écart de toute source de chaleur, notamment des fours, de l'humidité, des flaques d'eau, de l'huile ou de la graisse, des atmosphères corrosives et des intempéries.

Laissez en place tous les dispositifs de sécurité et tous les panneaux de la console et maintenez-les en bon état.

Utilisez l'équipement conformément à son usage prévu et n'effectuez aucune modification.



**INFORMATIONS SUPPLÉMENTAIRES RELATIVES À LA SÉCURITÉ** -- Pour obtenir de l'information supplémentaire sur les règles de sécurité à observer pour l'équipement de soudage à l'arc électrique et le coupage, demandez un exemplaire du livret "Precautions and Safe Practices for Arc Welding, Cutting and Gouging", Form 52-529.

Les publications suivantes sont également recommandées et mises à votre disposition par l'American Welding Society, 550 N.W. LeJuene Road, Miami, FL 33126 :

ANSI/ASC Z49.1 - "Safety in Welding and Cutting".

AWS C5.1 - "Recommended Practices for Plasma Arc Welding".

AWS C5.2 - "Recommended Practices for Plasma Arc Cutting".

AWS C5.3 - "Recommended Practices for Air Carbon Arc Gouging and Cutting".

AWS C5.5 - "Recommended Practices for Gas Tungsten Arc Welding".

AWS C5.6 - "Recommended Practices for Gas Metal Arc Welding".

AWS SP - "Safe Practices" - Reprint, Welding Handbook.

ANSI/AWS F4.1, "Recommended Safe Practices for Welding and Cutting of Containers That Have Held Hazardous Substances."

CSA Standard - W117.2 = Safety in Welding, Cutting and Allied Processes.



**SIGNIFICATION DES SYMBOLES** - Ce symbole, utilisé partout dans ce manuel, signifie "Attention"! Soyez vigilant! Votre sécurité est en jeu.

**DANGER**

Signifie un danger immédiat. La situation peut entraîner des blessures graves ou mortelles.

**MISE EN GARDE**

Signifie un danger potentiel qui peut entraîner des blessures graves ou mortelles.

**AVERTISSEMENT**

Signifie un danger qui peut entraîner des blessures corporelles mineures.

### Classe de protection de l'enveloppe

L'indice de protection (codification IP) indique la classe de protection de l'enveloppe, c'est-à-dire, le degré de protection contre les corps solides étrangers ou l'eau. L'enveloppe protège contre le toucher, la pénétration d'objets solides dont le diamètre dépasse 12 mm et contre l'eau pulvérisée à un angle de jusqu'à 60 degrés de la verticale. Les équipements portant la marque IP21S peuvent être entreposés à l'extérieur, mais ne sont pas conçus pour être utilisés à l'extérieur pendant une précipitation à moins d'être à l'abri.

**MISE EN GARDE**

Ce produit a été conçu pour la découpe au plasma seulement. Toute autre utilisation pourrait causer des blessures et/ou endommager l'appareil.

## MISE EN GARDE

L'équipement pourrait basculer s'il est placé sur une surface dont la pente dépasse 15°. Vous pourriez vous blesser ou endommager l'équipement de façon importante.

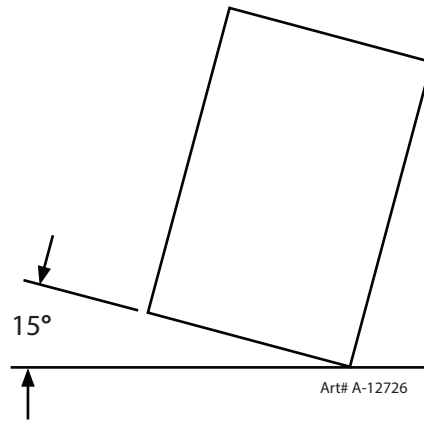
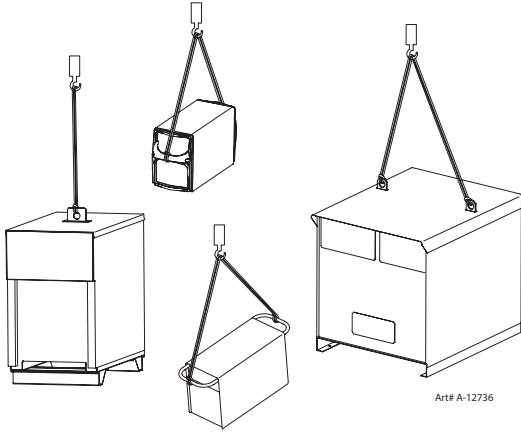

## MISE EN GARDE

Soulevez à l'aide de la méthode et des points d'attache illustrés afin d'éviter de vous blesser ou d'endommager l'équipement.

## SECTION 2: SPECIFICATIONS

### 2.01 General Description Of The System

A typical PAK 300i plasma cutting system includes:

- One Power Supply
- General Purpose Plasma Cutting Torch with Connecting Leads
- Torch Spare Parts Kit

The components are connected at installation.

### 2.02 Plasma Power Supply

The power supply provides the necessary current for cutting operations, and monitors system performance. The power supply also cools and circulates the liquid coolant for the torch and leads.

### 2.03 Plasma Cutting Torch

The torch delivers the controlled current to the work through the main arc, causing the metal to be cut.

### 2.04 System Component Layout

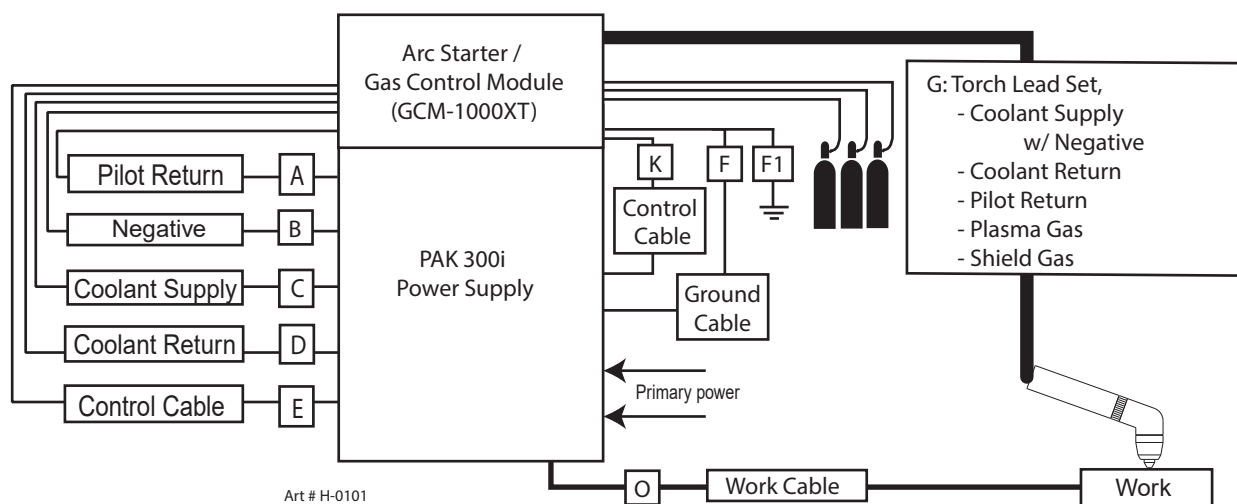

2.05 Power Supply Specifications & Electrical Requirements

SPECIFICATIONS

PAK 300i Specifications & Design Features		
300 Amp System	Max OCV (U0)	400-450 (line V dependent)
	Minimum Output Current	30 Amps
	Max Output Current	300 Amps
	Output Voltage/IEC	60 - 200 vdc/ 60-200 vdc
	Duty Cycle Rating	100% @ 300A, 200V, (60kW),
	Ambient Temperature for Duty Cycle Rating	104F° (40°C)
	Operating range	14°F to 122°F (-10°C to + 50°C)
	Power Factor	0.93 @ 300 A DC Output
	Cooling	Coolant and Forced Air (Class F)

PAK 300i Power Supply							
Input					Suggested Sizes (See Note)		
Voltage 3-ph (Volts)	Freq. (Hz)	Max Power (kVA)	Amps (Nominal output)	Amps (Max Rated)	Fuse (Amps) 3-Ph	Wire (AWG) 3-Ph	Wire (mm <sup>2</sup> ) 3-Ph
380	50/60	73	107	113	125	#3	35
400	50/60	75	102	110	125	#3	35
480	50/60	75	85	92	100	#4	25

*Amps (nominal output) is expected current at max listed thickness.  
Amps (Max rated) is current at 100% DC voltage (300A @ 200VDC).*

**NOTE!**  \* Suggested wire size based on United States NFPA 70 National Electrical Code 2011 edition published by the National Fire Prevention Association. Listings are from table 400.5(A)(2) for flexible cord of certain types rated for 75 deg C in ambient temperatures up to 30 deg C. Using wires of lower temperature rating or different insulation type may require larger wire size. Derate for higher ambient. These are suggestions only. Always refer to your local and national codes that apply to your region for final determination of correct wire type and size.

2.06 Power Supply Dimensions

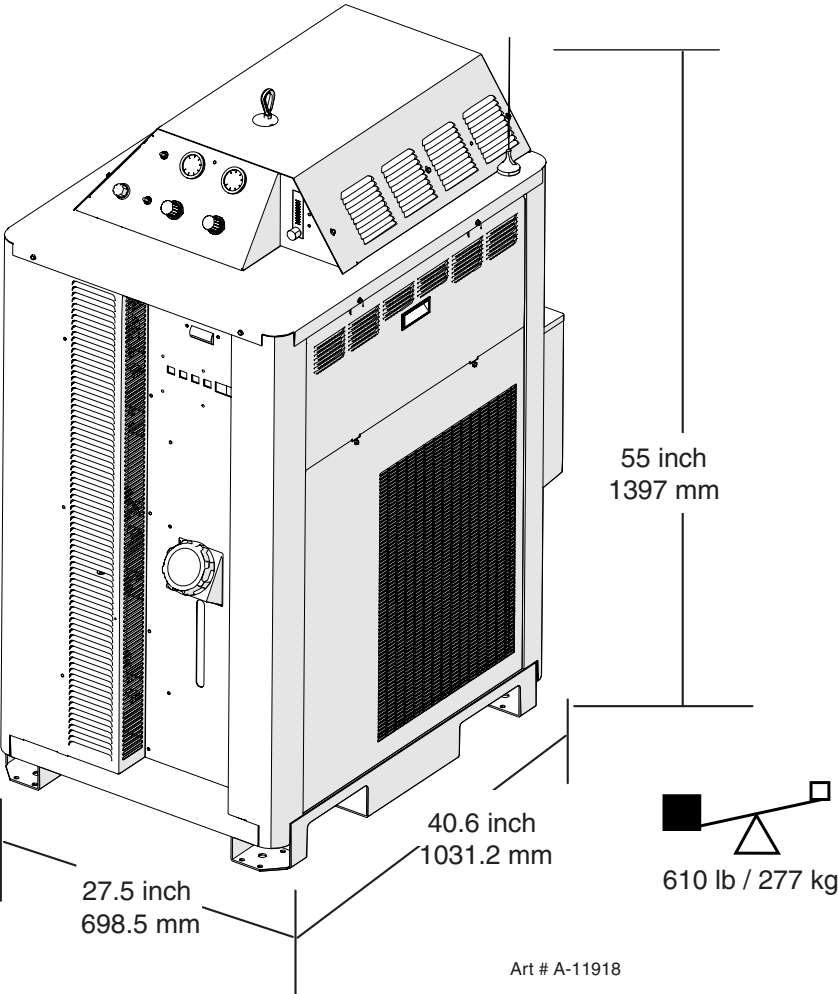

2.07 Power Supply Rear Panel Features

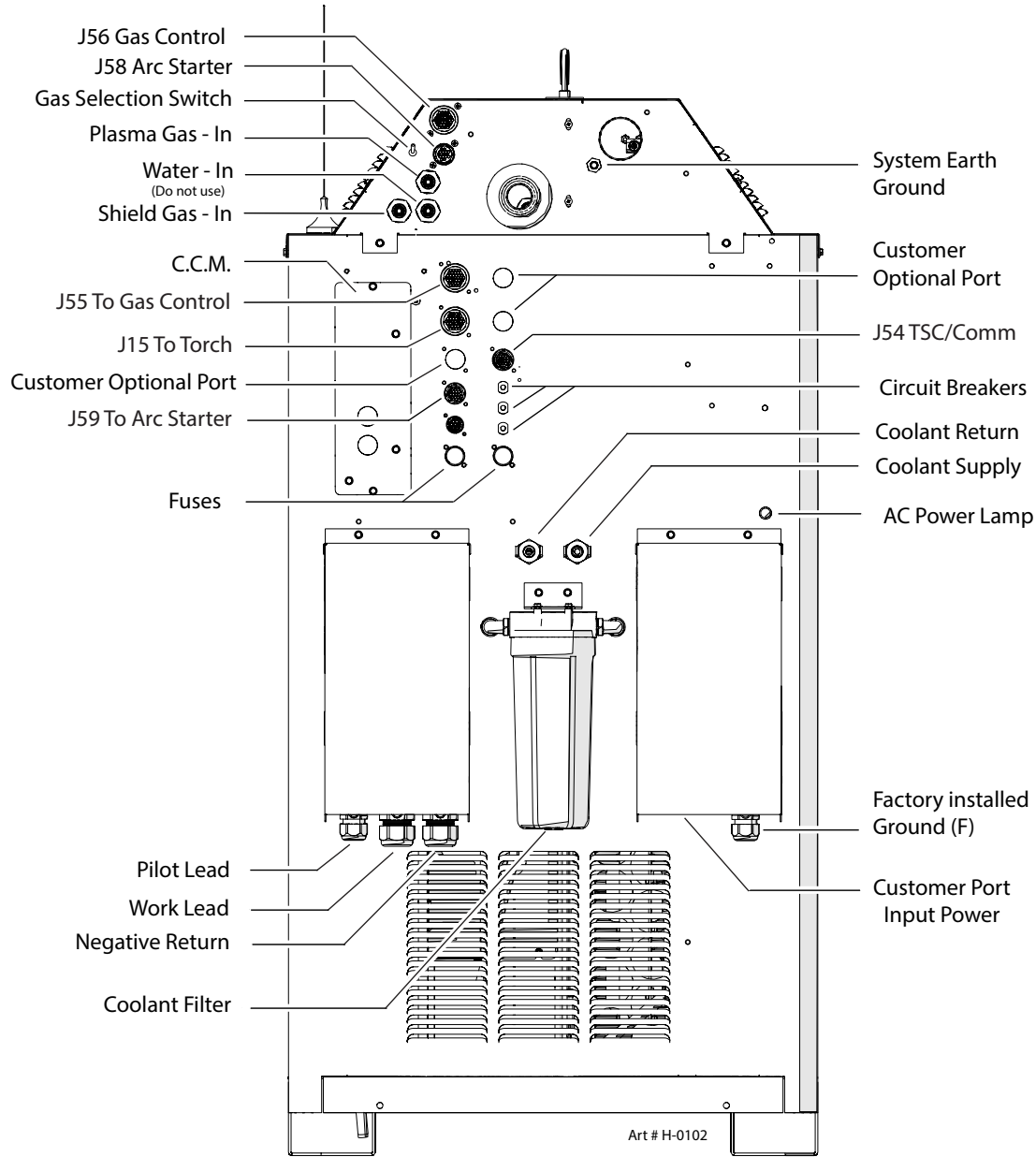

## 2.08 Gas Requirements

The customer will provide all gases and pressure regulators. Gases must be of high quality. Pressure regulators shall be equipped with stainless-steel diaphragms and installed as close as possible to the Gas Console.

PAK 300i Power Supply: Gas Pressures, Flows, and Quality Requirements			
Gas	Quality	Minimum Pressure	Flow
N <sub>2</sub> (Nitrogen)	99.5% Purity (Liquid recommended) <1000 ppm O <sub>2</sub> , <32 ppm H <sub>2</sub> O)	120 psi 8.3 bar / 827 kPa	300 scfh (141.6 lpm)
Compressed or Bottled Air	Clean, Dry, Free of Oil (see Note 1)	120 psi 8.3 bar / 827 kPa	450 scfh (212.4 lpm)
H35 (Argon-Hydrogen) H35 = 35% Hydrogen, 65% Argon	99.995% Purity (gas recommended)	120 psi 8.3 bar / 827 kPa	200 scfh (94.4 lpm)

Note 1: The air source must be adequately filtered to remove all oil or grease. Oil or grease contamination from compressed or bottled air can cause fires in conjunction with oxygen.

For filtering, a coalescing filter able to filter to 0.01 microns should be placed as close as possible to the gas inlets on the Gas Control Module.

## 2.09 Gas Applications

MATERIAL	MILD STEEL		STAINLESS STEEL		ALUMINUM	
	PLASMA	SHIELD	PLASMA	SHIELD	PLASMA	SHIELD
50A Cut	Air	Air	Air	Air	Air	Air
100A Cut	Air	Air	Air	Air	Air	Air
			N <sub>2</sub>	N <sub>2</sub>	N <sub>2</sub>	N <sub>2</sub>
			H35	N <sub>2</sub>	H35	N <sub>2</sub>
150A Cut	Air	Air	Air	Air	Air	Air
			N <sub>2</sub>	N <sub>2</sub>	N <sub>2</sub>	N <sub>2</sub>
			H35	N <sub>2</sub>	H35	N <sub>2</sub>
200A Cut	Air	Air	Air	Air	Air	Air
			N <sub>2</sub>	N <sub>2</sub>	N <sub>2</sub>	N <sub>2</sub>
			H35	N <sub>2</sub>	H35	N <sub>2</sub>
300A Cut	Air	Air	Air	Air	Air	Air
			N <sub>2</sub>	N <sub>2</sub>	N <sub>2</sub>	N <sub>2</sub>
			H35	N <sub>2</sub>	H35	N <sub>2</sub>

## 2.10 PT-26P Torch Specifications

### A. Torch Dimensions

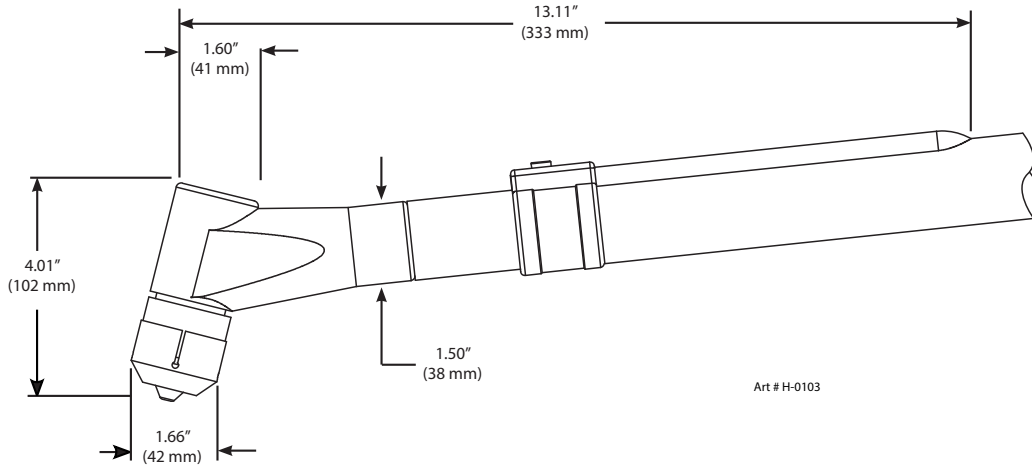

### B. Torch Leads Lengths

Torch Lead Assembly	
Lengths	
Feet	Meters
50	15.2

C. Torch Parts (Generic Parts Shown)

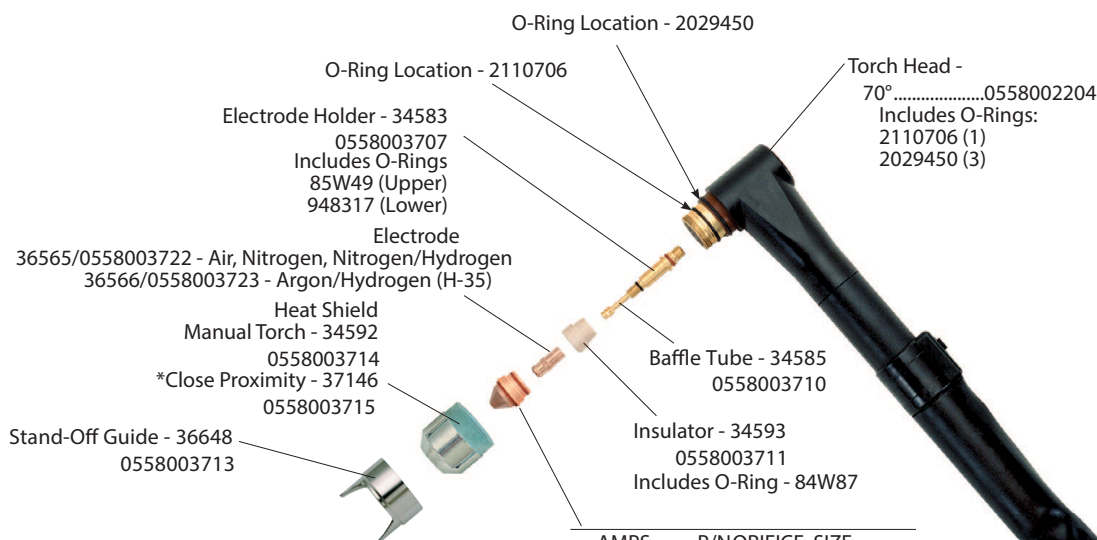

\* Close proximity Heat Shield. Optional for Manual Torch when cutting or gouging in close proximity of workpiece.

	AMPS	P/NORIFICE SIZE	
<b>Cutting Nozzle</b>			
**50	36567/0558003716	.052	
150	36568/0558003717	.078	
200	36569/0558003798	.089	
300	36570/0558003794	.104	
<b>Gouging Nozzle</b>			
200	36571/0558003718	.125	
300	36572/0558003795	.144	

All include O-Rings 2110578 (Upper)  
994092 (Lower)

Art # H-0108

SPECIFICATIONS

D. Parts - In - Place (PIP)

The torch is designed for use with a power supply which senses coolant return flow to confirm that torch parts are in place. If coolant return flow to the power supply is absent or insufficient the power supply will not provide power to the torch. Coolant leakage from the torch also indicates that torch parts are absent or installed improperly.

E. Type Cooling

Combination of gas stream through torch and liquid cooling.

2.11 Maximum Manual PT-26P Speeds

PT-26P Steel Cutting Data

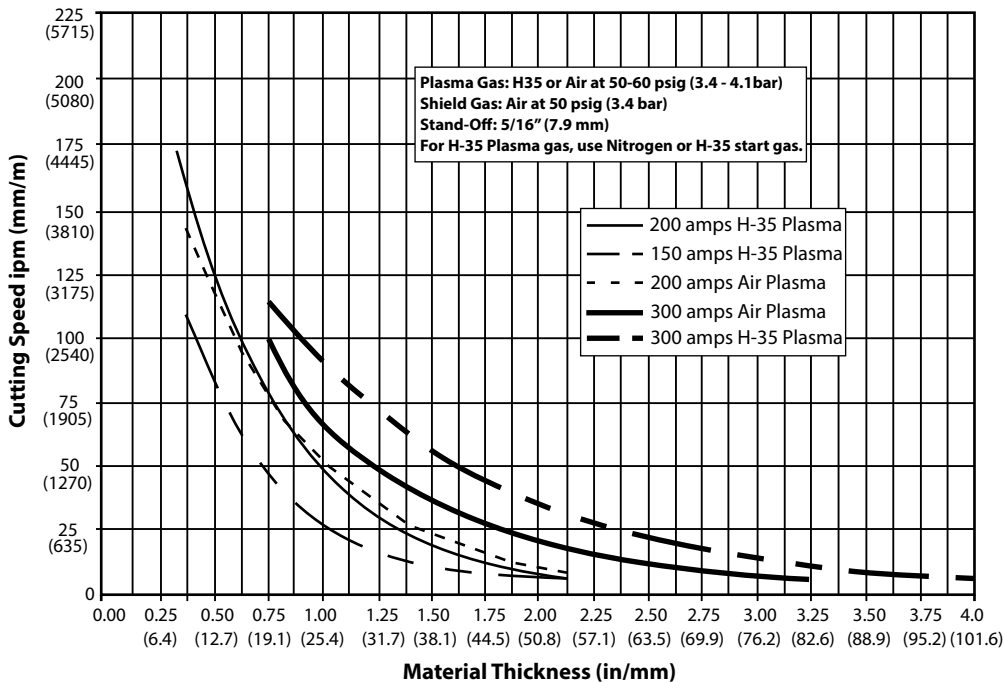
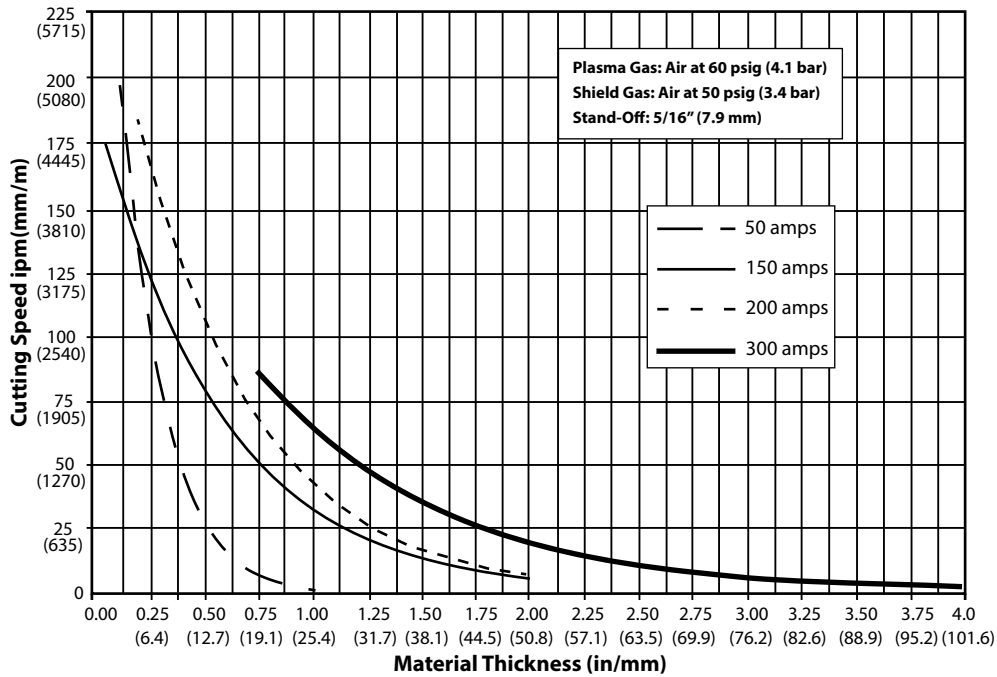

Art# H-0115

PT-26P Stainless Steel Cutting Data

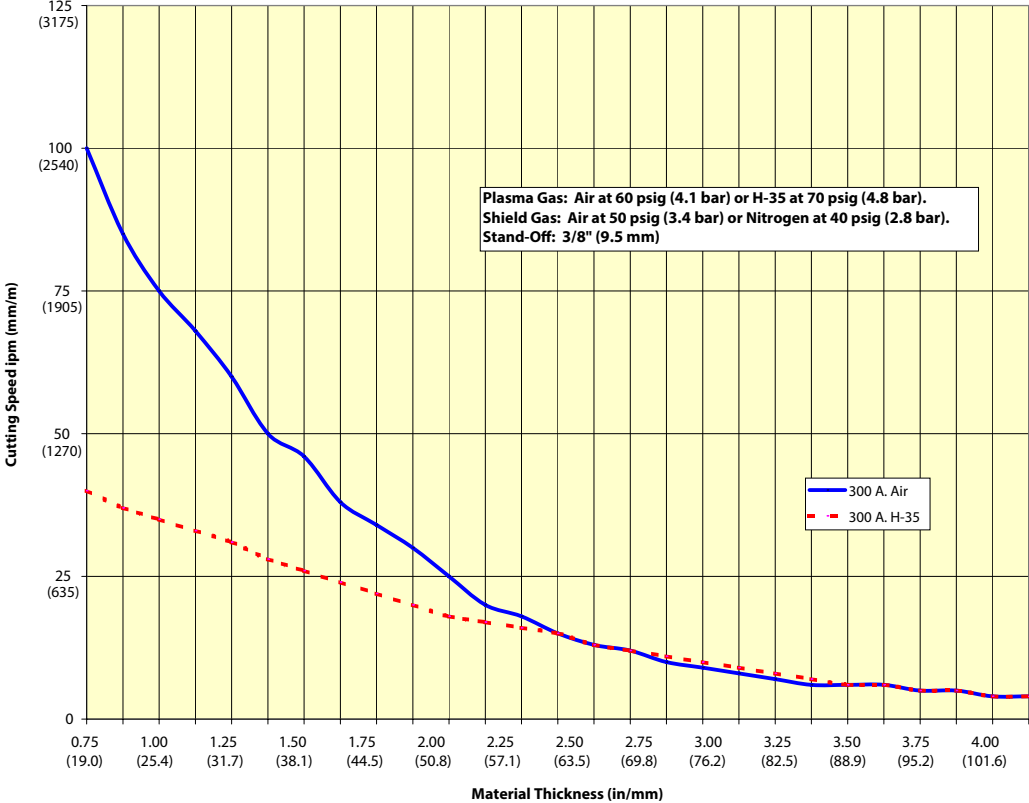
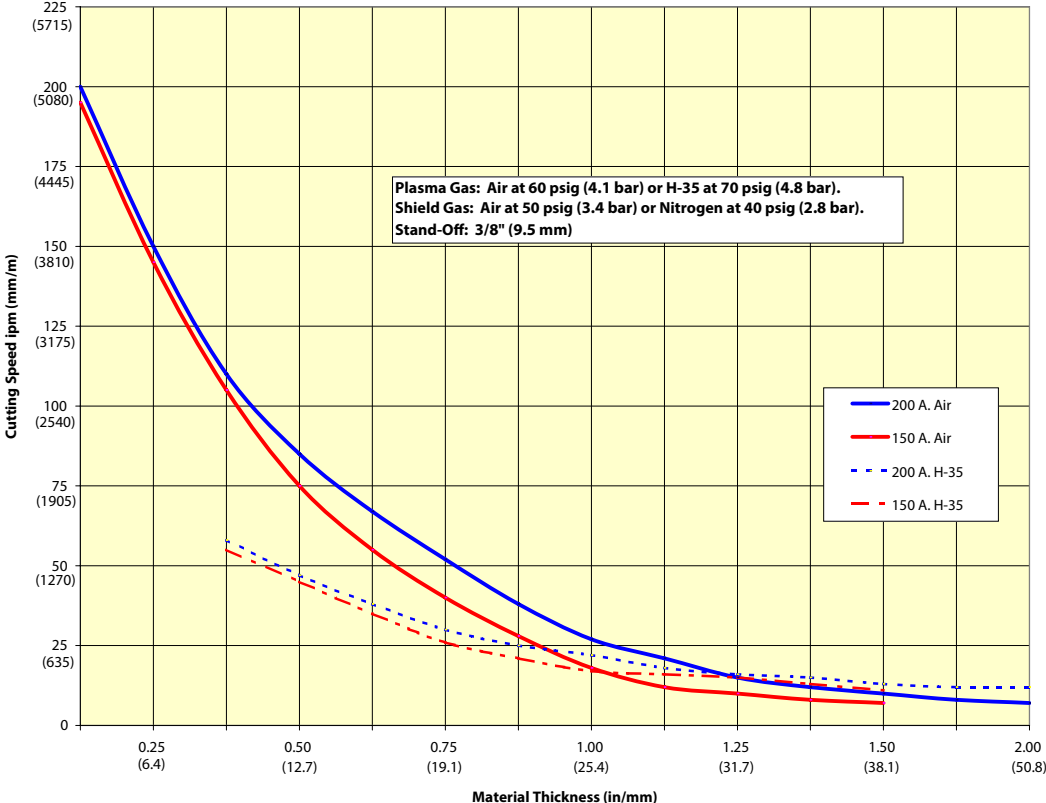

Art# H-0116

This Page Intentionally Blank

## SECTION 3: INSTALLATION

### 3.01 Installation Requirements

#### Electric Supply

The electrical supply network, the gas and water supply system must meet local safety standards. This conformity must be checked by qualified personnel.

PAK 300i Specifications & Design Features		
300 Amp System	Max OCV (U0)	400-450 (line V dependent)
	Minimum Output Current	30 Amps
	Max Output Current	300 Amps
	Output Voltage/IEC	60 - 200 vdc/ 60-200 vdc
	Duty Cycle Rating	100% @ 300A, 200V, (60kW),
	Ambient Temperature for Duty Cycle Rating	104F° (40°C)
	Operating range	14°F to 122°F (-10°C to + 50°C)
	Power Factor	0.93 @ 300 A DC Output
	Cooling	Coolant and Forced Air (Class F)

PAK 300i Power Supply							
Input					Suggested Sizes (See Note)		
Voltage 3-ph (Volts)	Freq. (Hz)	Max Power (kVA)	Amps (Nominal output)	Amps (Max Rated)	Fuse (Amps) 3-Ph	Wire (AWG) 3-Ph	Wire (mm <sup>2</sup> ) 3-Ph
380	50/60	73	107	113	125	#3	35
400	50/60	75	102	110	125	#3	35
480	50/60	75	85	92	100	#4	25

*Amps (nominal output) is expected current at max listed thickness.  
Amps (Max rated) is current at 100% DC voltage (300A @ 200VDC).*



#### NOTE!

\* Suggested wire size based on United States NFPA 70 National Electrical Code 2011 edition published by the National Fire Prevention Association. Listings are from table 400.5(A)(2) for flexible cord of certain types rated for 75 deg C in ambient temperatures up to 30 deg C. Using wires of lower temperature rating or different insulation type may require larger wire size. Derate for higher ambient. These are suggestions only. Always refer to your local and national codes that apply to your region for final determination of correct wire type and size.



#### CAUTION

Fuse and wire sizes are for reference only. The installation must conform to national and local codes for the type and method of wire being used.

## Gas Supply

The customer must supply all gas and pressure regulators. Gases must be of high quality. Pressure regulators must be double-stage and installed as close as possible to the gas console. Contaminated gas can cause one or more of the following problems:

- Reduced cutting speed
- Poor cut quality
- Poor cutting precision
- Reduced consumables life.
- Oil or grease contamination from compressed or bottled air can cause fires in conjunction with oxygen.

## Cooling System Requirements

Coolant must be added to the system on installation.

Thermal Dynamics recommends the use of its coolants 7-3581 (for low temperatures).

Coolant Capabilities		
Cat. Number and Mixture	Mixture	Protects To
7-3581 'Ultra-Cool™'	50 / 50	-27° F / -33° C
7-3582 'Extreme Cool™'	Concentrate*	-76° F / -60° C
* For mixing with D-I Cool™ 7-3583		

## 3.02 Cables and Leads Identification

Refer to section 3.05 and 3.06 for ground connections and ground cables.

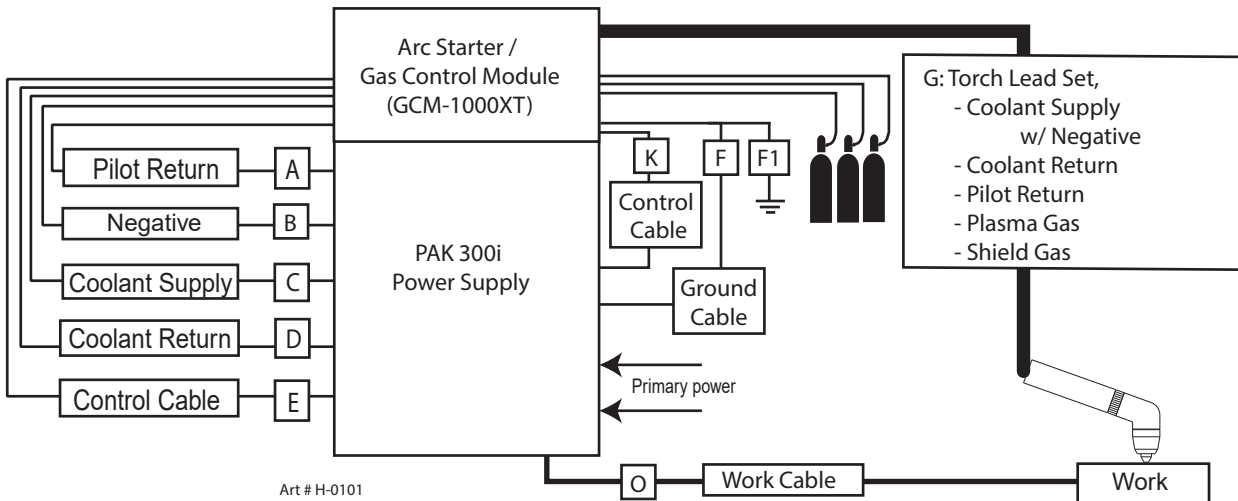

3.03 Cables & Leads Identification

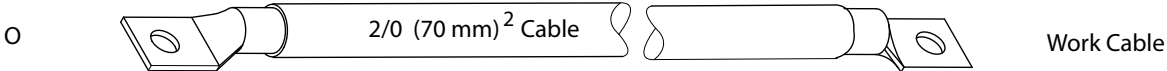
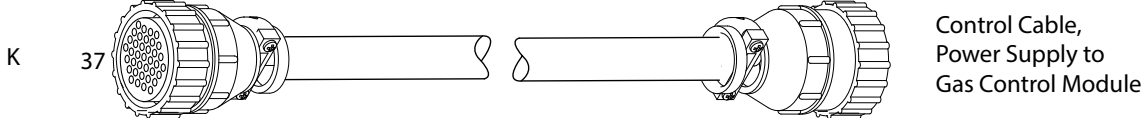
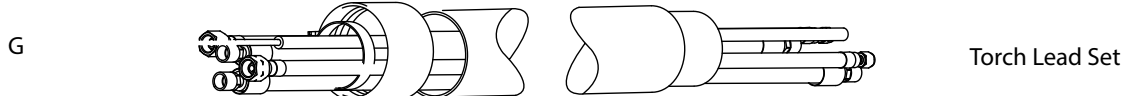
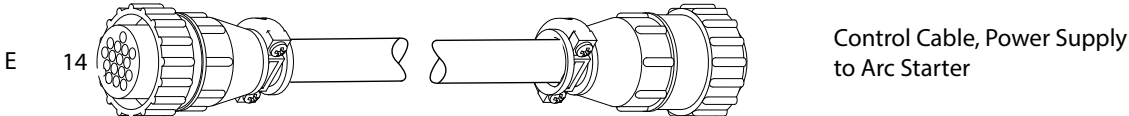

Art # H-0107

PT-26P Torch only for PAK 300i

INSTALLATION

### 3.04 Position the Power Supply



**WARNING**

Do not touch live electrical parts.  
Disconnect input power conductors from de-energized supply line before moving unit. **FALLING EQUIPMENT** can cause serious personal injury and equipment damage.  
Use the lifting eye when using straps to lift the power supply.

Use a forklift, crane, or hoist to lift the unit off the shipping pallet as shown. Keep the power supply steady and vertical. Do not lift it any further than necessary to clear the shipping pallet.

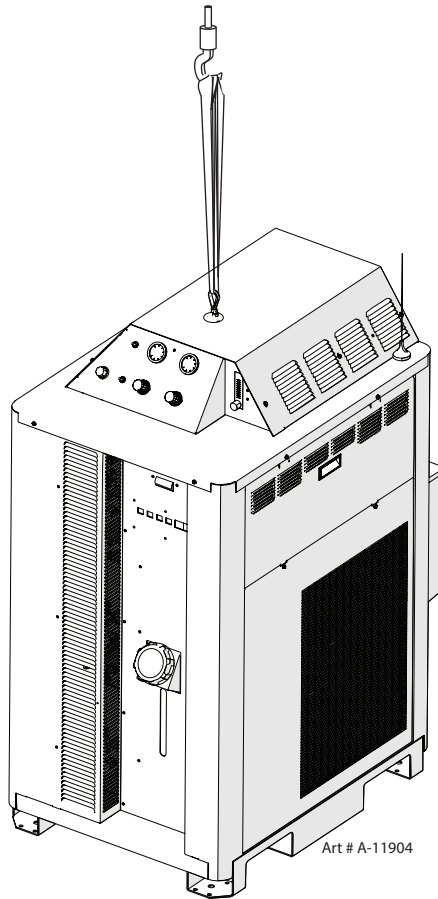

Set the power supply on a solid, level surface. The installer may fasten the power supply to the floor or a supporting fixture with hardware passing through the horizontal parts of the power supply feet.

### 3.05 Connect Input Power and Ground Cables

#### Connect Input Power and System Ground Cables

1. Remove the input power cover to the right of the coolant filter at the rear of the power supply. To do this remove the two screws then lift up and pull away.
2. Carefully cut back the outer sheath on the primary input power cable to expose the individual wires. Cut back the insulation on the individual wires. Route the cable upward through Input Power Port at the bottom of the panel. There are 2 extra plates included at the cable entrance. Discarding one or both allows changing the opening size for larger cable/strain relief.
3. Install stripped end of 3 phase wires into the terminal block L1, L2 and L3 and connect the individual cables as shown.
4. Connect the power cable ground wire to the ground terminal block.
5. Route a system ground cable (F1) to the stud on the rear of the gas control/arc starter Refer to the Ground Connections Section for full details and procedures on proper system grounding.

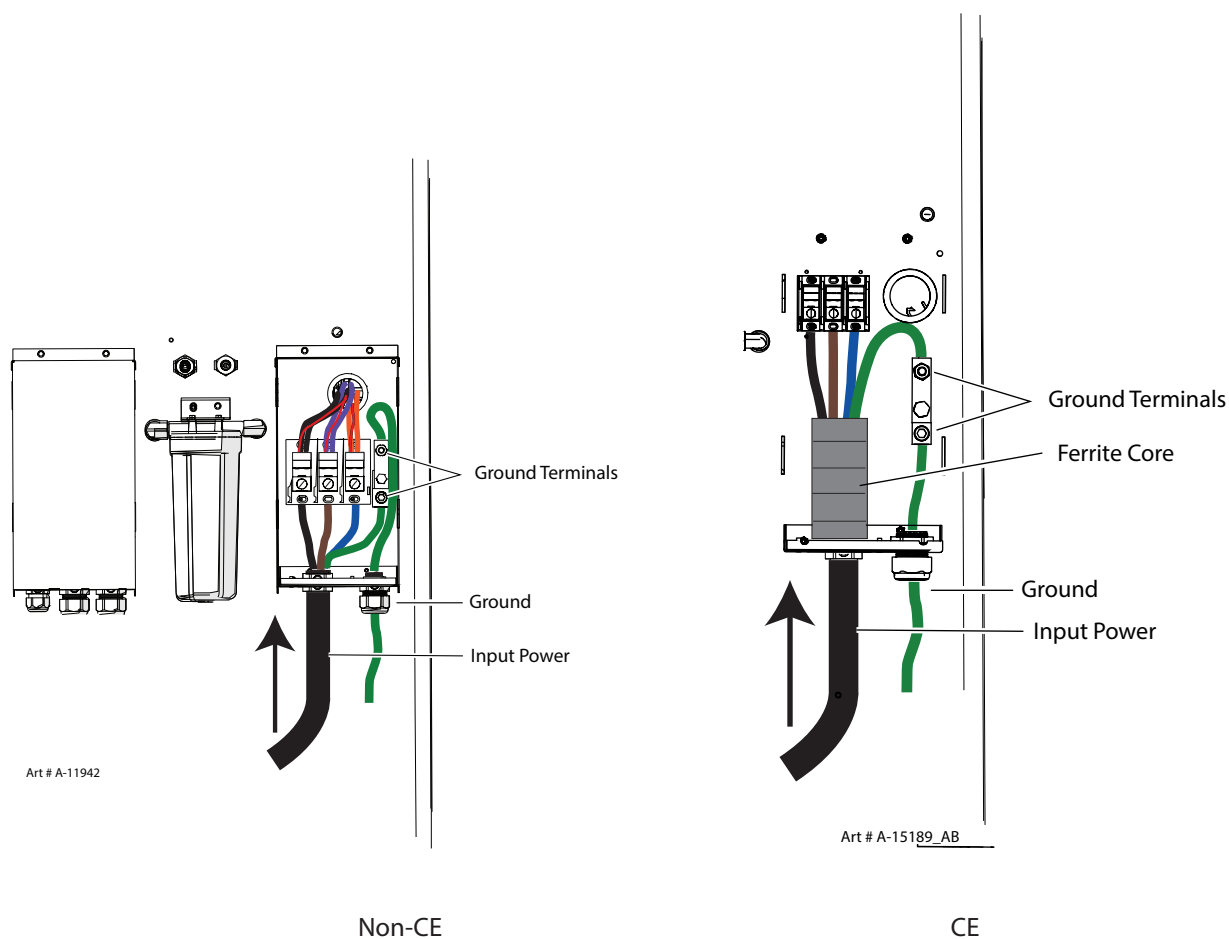

### 3.06 Connect Work Cable to Power Supply

1. Remove the output power cover to the left of the coolant filter at the rear of the power supply. To do this remove the two screws then lift up and pull away.
2. Route the end of the work cable upward through the leads strain relief at the bottom edge of the left rear panel. Pilot and Torch are factory installed.
3. Refer to the illustration. Connect the leads as shown. Tighten securely. Do not overtighten.

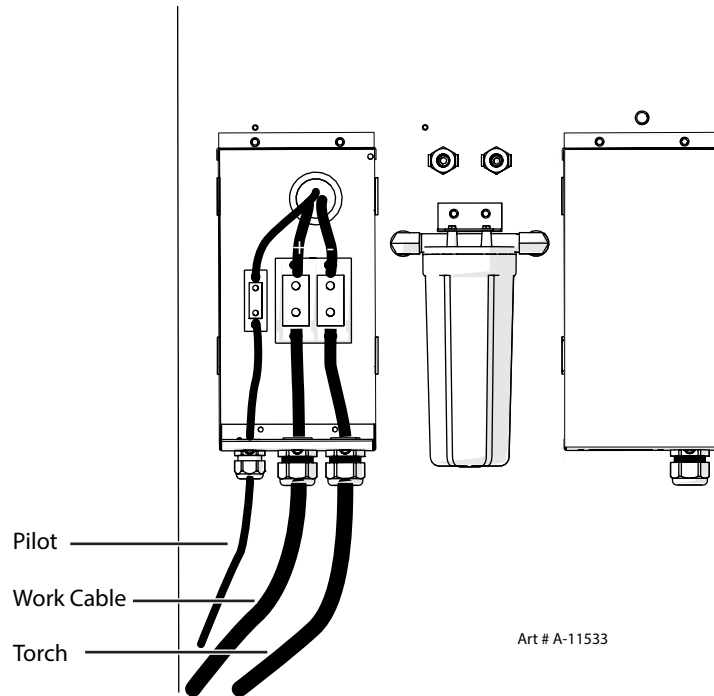

4. Reinstall the cover on the power supply. Secure with two screws removed earlier. Do not overtighten.

### 3.07 Connect Gas and Coolant Supply Lines

- 1. Connect the gas supply lines to the appropriate input ports as shown, upper left.

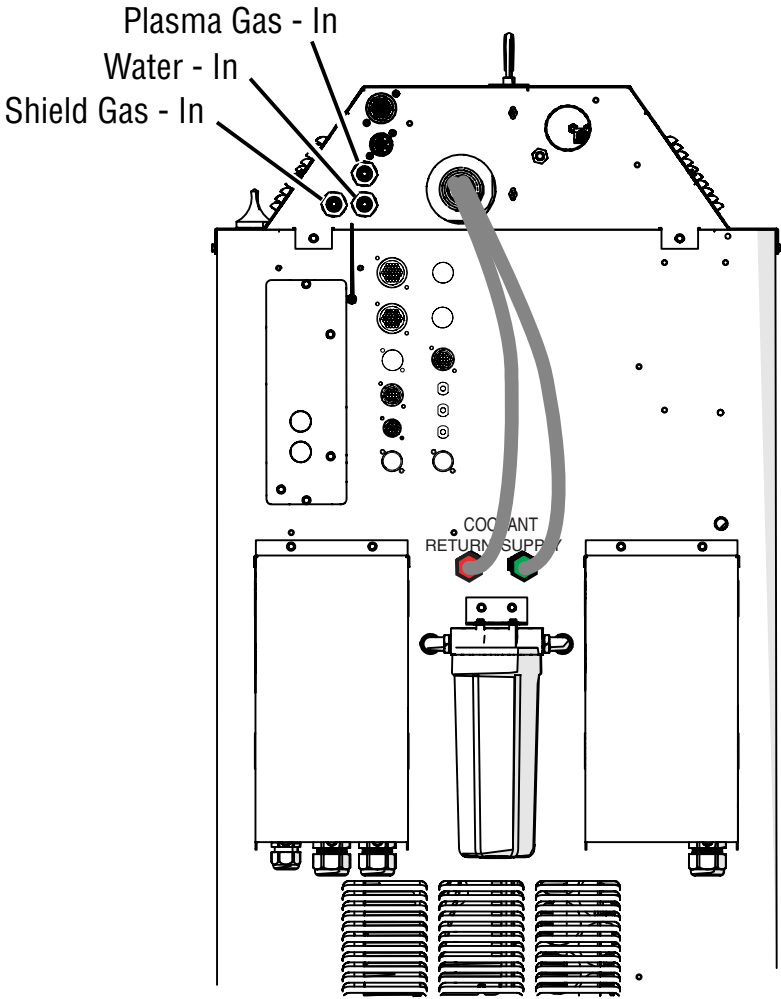

Art # A-11906

INSTALLATION

### 3.08 Cables for Remote Control and Torch

1. Connect one end of each cable to the power supply. Some cables shown are options and may not apply to your system.
2. Connect the other end of the CNC cable to the CNC device.



**NOTE!**

The CNC cable shield must be attached to ground at the CNC end.

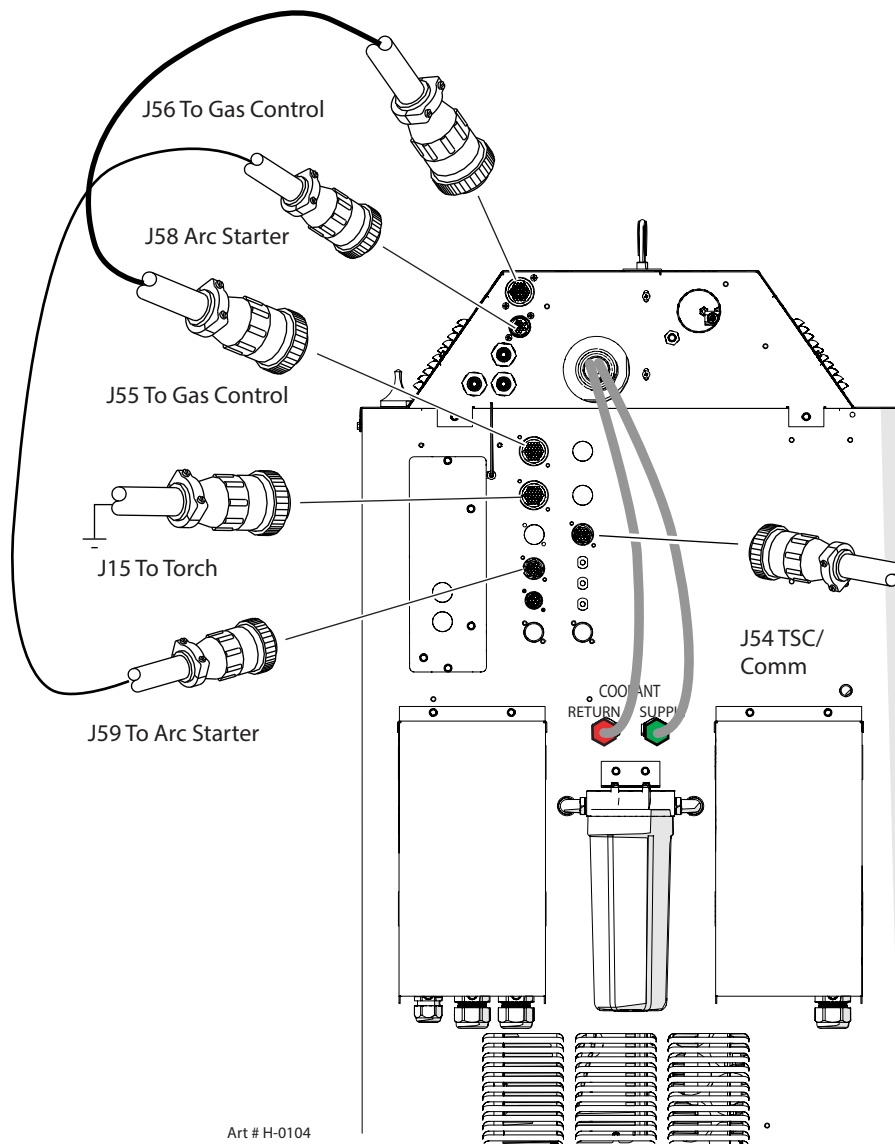

### 3.09 Set Switches on the Command - Control Module

Remove the power supply upper right side. Set switches on the CCM (Command-Control Module) per the illustrations. Switch settings and connection details are provided in the Appendix. Any changes made require a restart of the power supply.



**CAUTION** Printed circuit boards in the Command - Control Module are static - sensitive. Discharge any built-up static charges in your body or surroundings before touching the printed circuit boards.

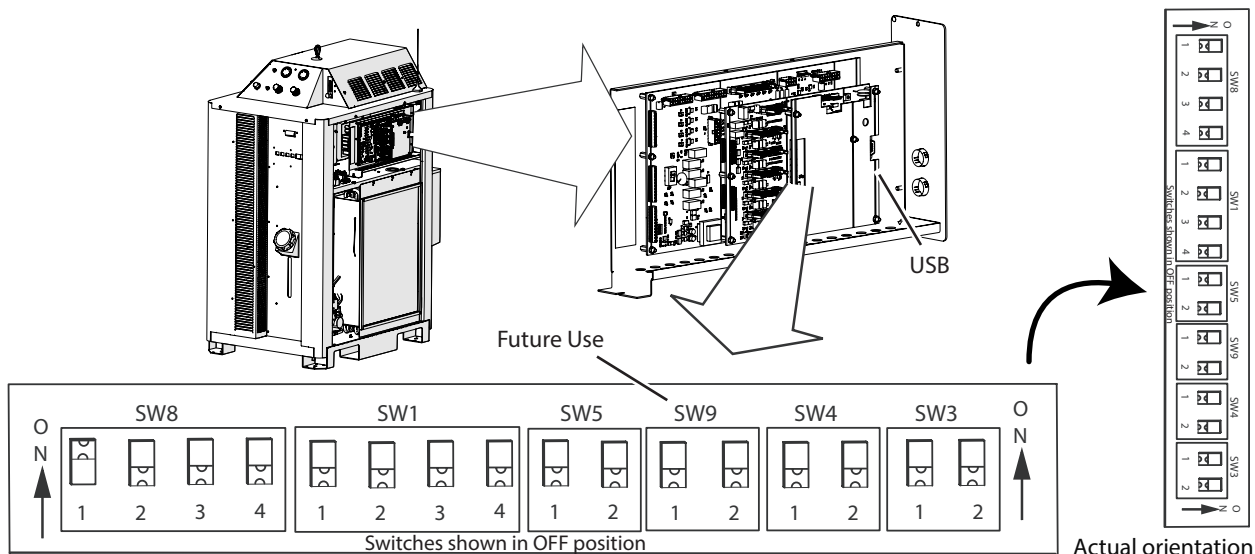

SW 8-1: Pilot Time	1 = ON = Long (16 s.) (Factory default setting) 1 = OFF = Short (85 ms.)
SW 8-2: Remote Current	1 = OFF = Disabled (Factory default setting).
*SW 8-3: Auto Transfer Retry	1 = OFF = Enabled Up to 3 tries (Factory default setting). 1 = ON = Disabled
SW 8-4:	OFF = Disabled (Factory default setting).
S W-1-1: Auto Pilot Restart.	1 = ON = Auto Pilot Function enabled. 1 = OFF = Auto Pilot Function disabled (Factory default setting).
S W-1-2: Pilot Delay	2 = OFF, 3 = OFF, 4 = OFF: 0 Seconds (Factory default setting).
S W-1-3: Pilot Delay	2 = ON, 3 = OFF, 4 = OFF: 0.1 Seconds
S W-1-4: Pilot Delay	2 = OFF, 3 = ON, 4 = OFF: 0.2 Seconds 2 = ON, 3 = ON, 4 = OFF: 0.4 Seconds 2 = OFF, 3 = OFF, 4 = ON: 0.8 Seconds 2 = ON, 3 = OFF, 4 = ON: 1.0 Seconds 2 = OFF, 3 = ON, 4 = ON: 1.5 Seconds 2 = ON, 3 = ON, 4 = ON: 2.0 Seconds
S W-5-1: Tip Saver	Reserved for Factory use.
SW-5-2: Off Plate	Reserved for Factory use.
S W-4: Postflow Time	1 = OFF, 2 = OFF: 10 Seconds (Factory default setting). 1 = ON, 2 = OFF: 20 Seconds 1 = OFF, 2 = ON: 5 Seconds 1 = ON, 2 = ON: 0 Seconds
SW-3: Gas Prewlow Time	1 = Off, 2 = OFF: 3 seconds 1 = ON, 2 = OFF: 4 seconds 1 = OFF, 2 = ON: 6 seconds 1 = ON, 2 = ON: 8 seconds

Active only when SW-1-1 is set to ON.

Art # H-0105



**CAUTION**

Printed circuit boards in the Command - Control Module are static - sensitive. Discharge any built-up static charges in your body or surroundings before touching the printed circuit boards.

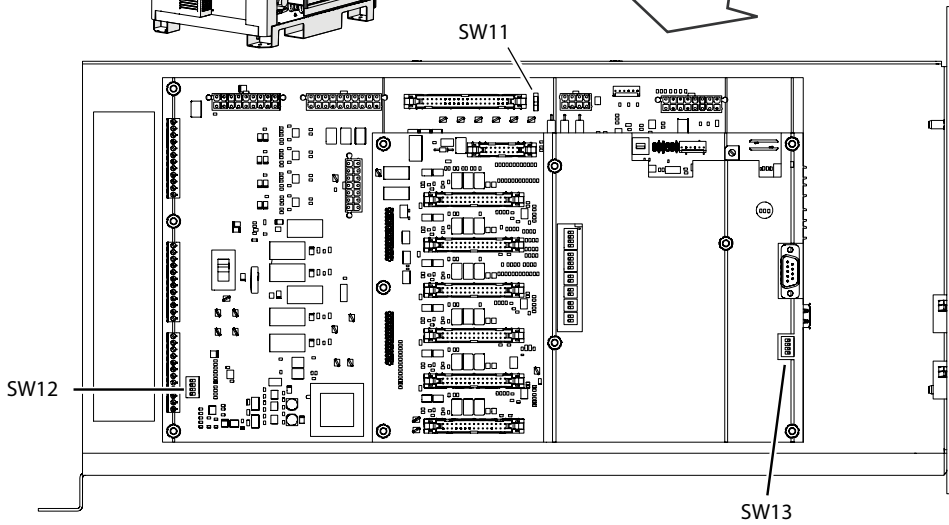
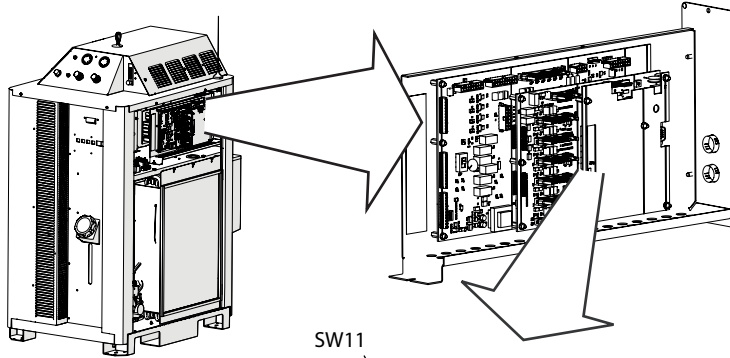

SW-11: Set "B" position, (up) for default

SW13-2: PAK 300i switch positions, ON

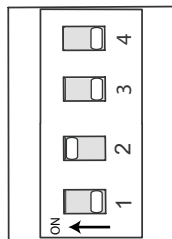

Art # H-0106

SW13 (Note positions 3-4 are not yet used)

### 3.10 Connect Torch Leads to the Arc Starter

1. Remove the top cover from the Gas Control Module / Arc Starter.
2. Pass the torch leads and coolant leads through the torch leads port on the back of the module. Ensure that the leads outer jacket slides into the port.



#### CAUTION

Use protective gloves when handling the leads. Do not kink or bend the leads.

3. Connect the leads to the module in the sequence shown. Coolant leads and connectors are color-tagged; red for coolant return, green for coolant supply. Shield gas and plasma gas connections are left- and right- hand threaded and will not interchange.

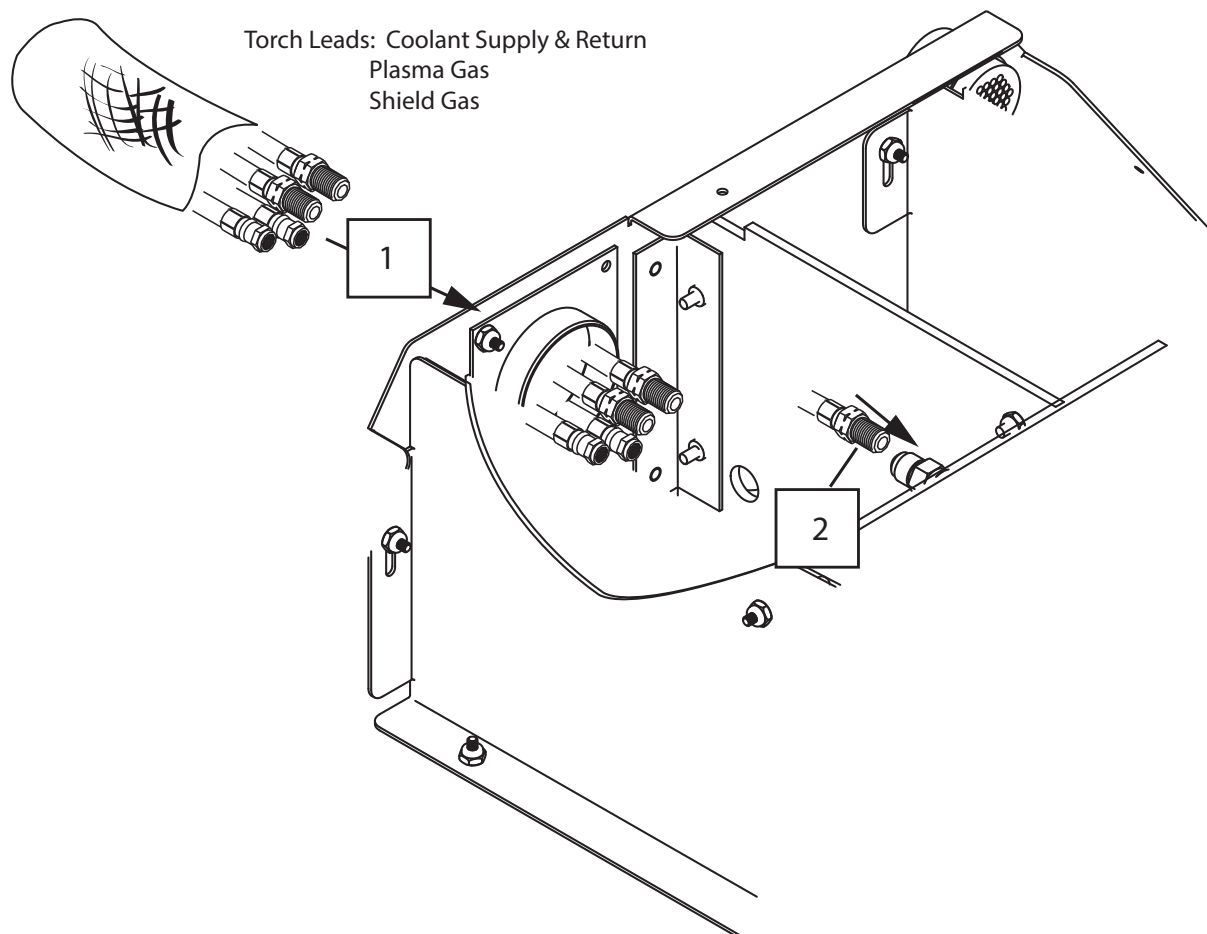

Art # H-0141

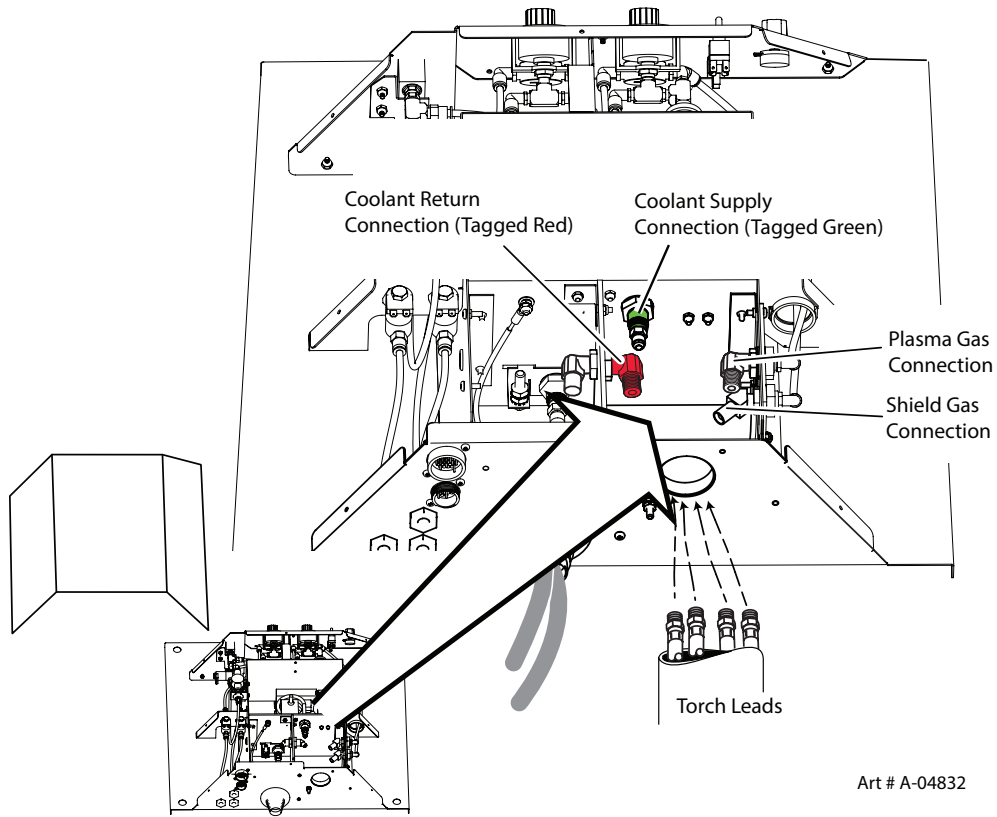

4. Fold the end of the leads outer jacket back over the connection ring inside the module. Re-install the module top cover.

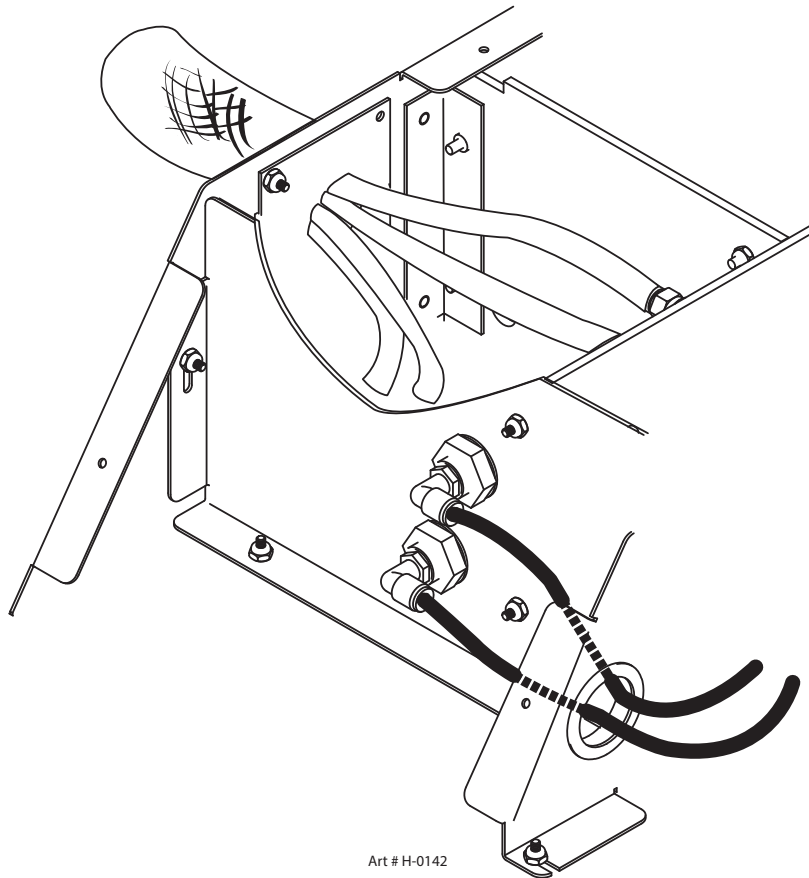

### 3.11 Fill Cooling System

- 1. Fill the coolant tank to the level shown, with Thermal Dynamics coolant. The coolant level is visible through the translucent coolant tank. The amount of coolant required varies with torch leads length.
- 2. Replace the cap on the tank.

Coolant Capabilities		
Cat. Number and Mixture	Mixture	Protects To
7-3580 'Extra-Cool™'	25 / 75	10° F / -12° C
7-3581 'Ultra-Cool™'	50 / 50	27° F / -33° C
7-3582 'Extreme Cool™'	Concentrate*	-65° F / -51° C

\* For mixing with D-I Cool™ 7-3583

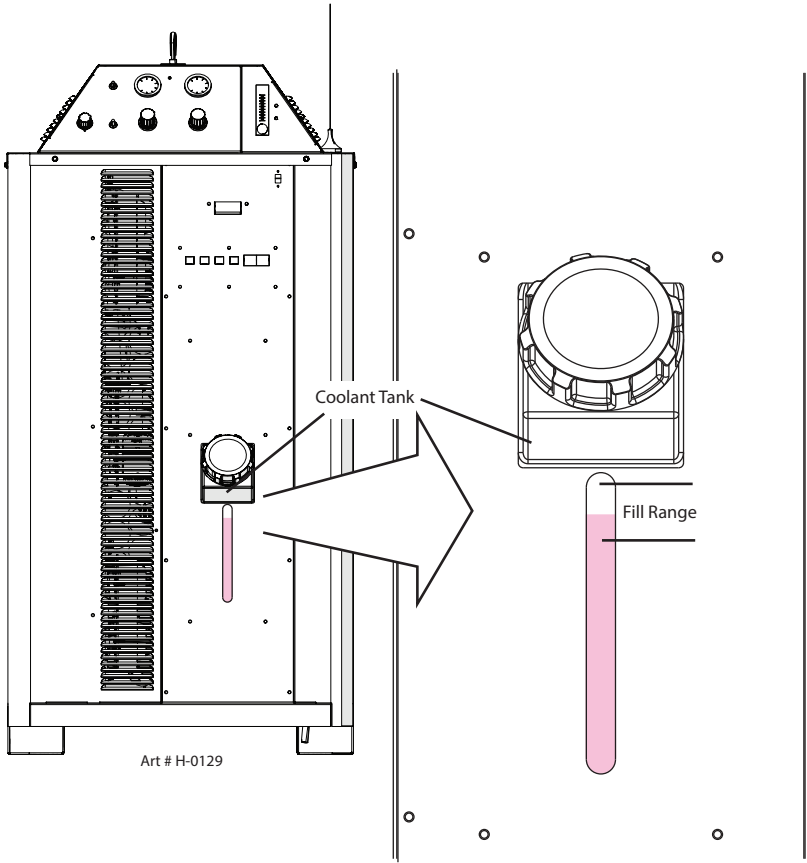

INSTALLATION

2. After the complete system has been installed, check that the coolant has been pumped through the system as follows (see NOTE):

**NOTE!**

The system will most likely require more coolant after turning the system ON for the first time.

- a. Place the ON/OFF Switch to ON. The power supply will start to circulate coolant throughout the system.
  - b. After about 4 minutes the system may shut down if the leads are not full of coolant.
  - c. Place the ON/OFF switch to OFF. Refill Coolant Tank as needed.
  - d. After 10 seconds place the ON/OFF switch to ON again.
  - e. Repeat steps 'b' through 'd' until the system no longer shuts down. Depending on the length of the torch leads this sequence may need to be done three to five times.
  - f. After the system stays operational allow the pump to operate for ten minutes to properly purge any air from the coolant lines before using the system.
3. Re-fill the reservoir and re-install the filler cap.

**NOTE!**

Circuitry in the power supply will generate a 'Low coolant' message if the coolant level is too low.

## SECTION 4: OPERATION

### 4.01 Power Supply Indicators

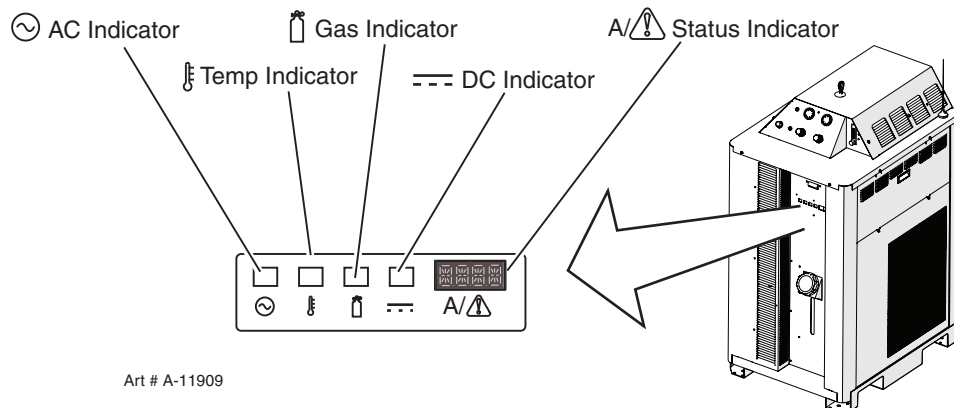

#### AC Power Lamp

Indicates unit has passed the input power tests and AC power is being supplied to the inverter modules via the input contactor when the ON/OFF switch is in ON position.



**TEMP Lamp:** Normally OFF. Lamp will come ON when the internal temperature sensors detect temperatures above normal limits. Let the unit cool before continuing operation.



**GAS Lamp:** Flashing during start up gas purge/pump priming, then steady whenever gas is flowing. Indicates adequate gas pressure and coolant flow for operation.

**DC Lamp:** Indicates the power supply is generating output DC voltage.



**Status Indicator:** Shows CCM code version on start up followed by the Current Control setting and system status. Refer to Section 4.05 and Status Code Section for details.

#### Rear Panel AC Power Lamp

Indicates AC power is present inside the unit

4.02 Control Console Features

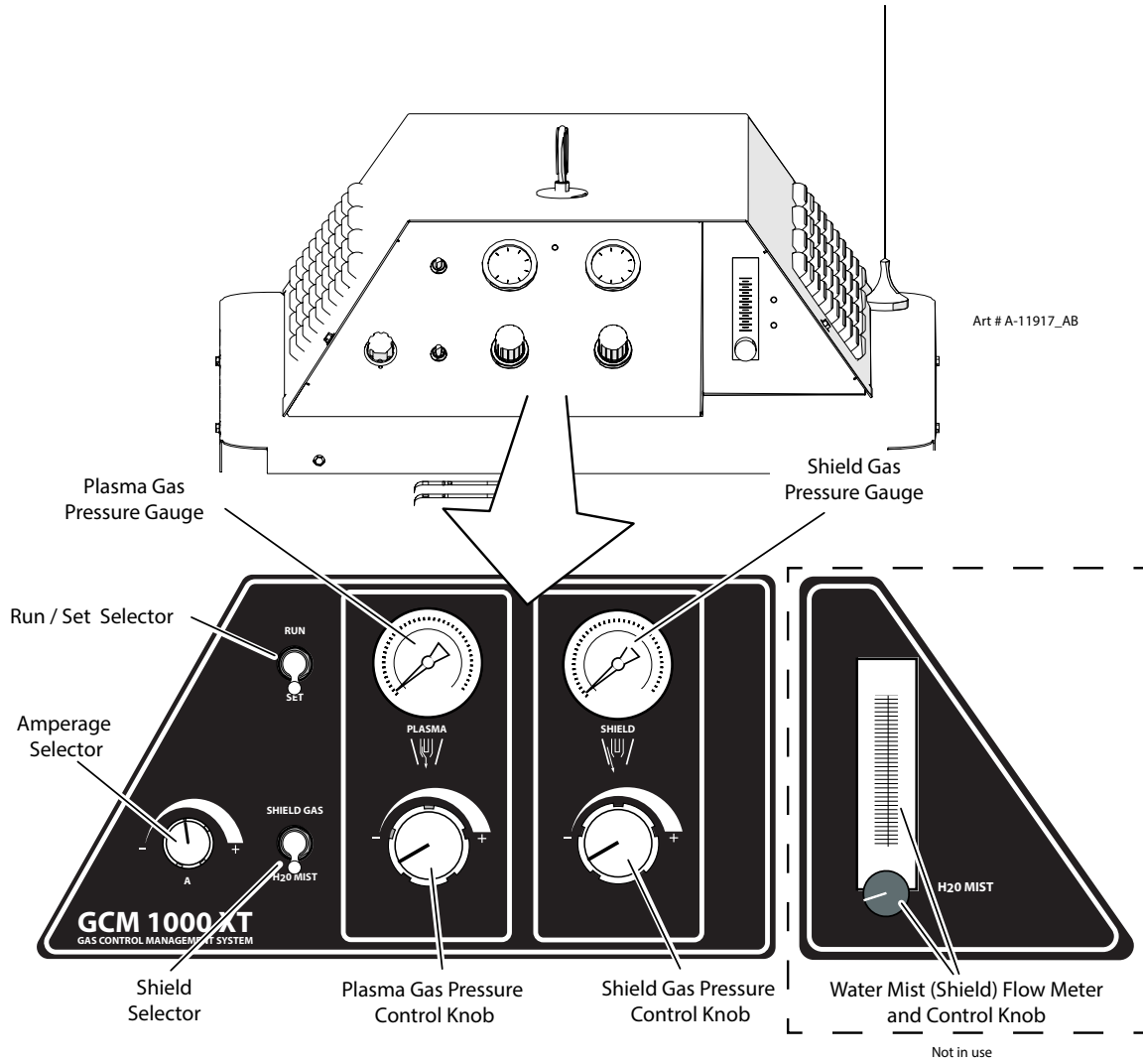

OPERATION

**Run / Set Selector:** Use SET position to adjust plasma and shield pressures and flows. Once these are set, switch to RUN position for operation.

**Plasma and Shield Gas Pressure Control Knobs:** Adjust plasma and shield gas pressures. Turn knobs to set desired levels.

**Plasma and Shield Gas Pressure Gauges:** Display plasma and shield gas pressures.

**Shield Selector:** Selects shield fluid, gas.

**Amperage Selector:** Continuously adjustable to 300 Amps. Visible here:



**Plasma Gas Type Selector (rear panel):** Selects proper operating voltage for either Air or N2 & H35. Also use N2/H35 setting for F5.

## 4.03 System Operation

This section contains operating information which is specific to the power supply.



### WARNING

Frequently review the safety precautions in Section 1.

If the power supply cord has a plug or is not permanently connected to power, be sure the power to the outlet is disconnected when inserting the plug into the outlet.

Disconnect primary power at the source before assembling or disassembling power supply, torch parts, or torch and leads assemblies, or adding coolant.

It is not enough to simply move the ON/OFF switch on the unit to OFF position when cutting operations have been completed. Always open the power supply disconnect switch five minutes after the last cut is made.

Prior to starting the system determine the process to be used. The process is determined by the type and thickness of the metal to be cut. Select and install the required consumables, connect the required gasses to the system.

1. Connect system to primary input power. An indicator will light on the rear panel when AC power is applied to the unit. Place the Gas Control in the RUN mode.
2. Turn ON/OFF switch to ON (up) position. System goes through the "Start up Sequence".
  - For about 10 seconds the decimal points of the 4 digit display blink from right to left.
  - Next the 4 rectangular LED indicators illuminate all segments as a test.
  - Then for about 6 seconds the display shows the letter "C" (code) followed by the CCM code version. Example "C1.2.0". During this time various input voltage tests are being performed. If a fault is found its code is displayed and the start up sequence halts. Faults will show "E" or "L".
  - The coolant pump then starts and the Gas indicator blinks while the cutting gasses are purged for 20 seconds. Gas LED should stop blinking and gas flow (purge) stops unless gas control was left in the SET mode or the coolant flow is not satisfied. At the same time the display shows the current control setting. Example: "200"
  - Once coolant flow is detected, usually within 5 seconds after the pump starts, the W1 input contactor closes and the AC indicator lights. However if correct coolant flow was not obtained the contactors will not close and the Gas LED will continue blinking until required coolant flow has been obtained. The Gas LED will blink for up to 4 minutes after which code E404 will be displayed indicated proper coolant flow was not established.

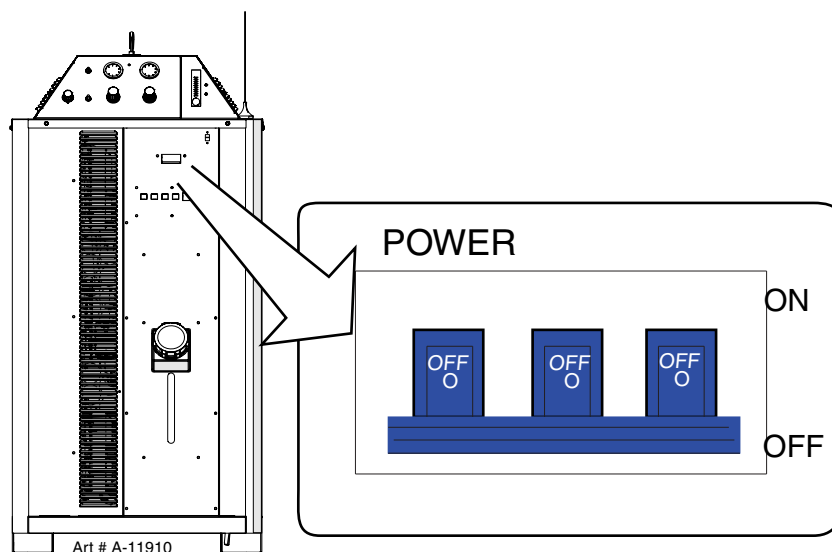

3. Set Gas Pressures
  - a. Place RUN/SET switch in SET mode.
  - b. Adjust plasma and shield pressure regulators to correct pressure.
  - c. Return RUN/SET switch to RUN mode. Attempting to START while in the SET mode will cause fault L303, normally indicating low gas pressure but in Auto-Cut XT units also indicates trying to START while in SET.
4. Set cutting current.
  - a. Adjust the Current Control knob to the required output current on the 4 digit display.
5. Prepare to cut.
  - a. Protect your eyes and ears.
  - b. Position the Torch to the proper transfer distance above the work piece.
6. Apply START.
  - Gas indicator lights; Gas pre-flow starts.
  - During gas pre-flow power supply is enabled. DC lamp turns ON.
7. Pilot Arc
  - At the end of pre-flow, ignition occurs (arcstarter fires) and the Pilot Arc is established.
  - Pilot time is maximum of 16 seconds. Piloting longer than necessary adds to consumable wear.
8. Transfer
  - Almost immediately, if the torch is positioned correctly, the pilot arc transfers to the work and becomes a cutting (transferred) arc.
  - Current quickly ramps up to the level set by the Current Control and the arc pierces through the metal.
9. End of Cut
  - START signal is removed; current ramps down and the arc goes out.
  - Gases continue to flow for the selected Post-flow time then stops.
  - Pump will run for 4 minutes then shut off. Fan will remain on as long as power is on.
10. To make another cut repeat steps 5-9. A second cut can be started anytime after completing the first cut.
11. Shut off the system.
  - a. Set the ON/OFF power switch on the front panel of the unit to OFF.



- Fans and pump as well as all indicators turn off.
- The display may show a fault code for a moment, this is a normal part of shutting off power and does not indicate a fault.
- b. Open (turn off) the main power disconnect. All power is now removed from the unit.
  - Rear panel AC indicator turns OFF.

### Operational Suggestions

1. Wait four minutes before setting the ON/OFF switch to OFF after operation. This allows the cooling fans to run to dissipate operating heat from the power supply.
2. For maximum parts life, do not operate the pilot arc any longer than necessary.
3. Use care in handling torch leads and protect them from damage.

## 4.04 Gas Selection

### A. Plasma Gases

1. Air Plasma
  - Most often used on ferrous or carbon base materials for good quality at faster cutting speeds.
  - Air plasma is normally used with air shield.
  - Only clean, dry air is recommended for use as plasma gas. Any oil or moisture in the air supply will substantially reduce torch parts life.
  - Provides satisfactory results on nonferrous materials.
2. Argon/Hydrogen (H35) Plasma
  - Recommended for use on 3/4 in (19 mm) and thicker stainless steel. Recommended for 1/2 inch (12 mm) and thicker nonferrous materials. Ar/H<sub>2</sub> is not normally used for thinner nonferrous materials because less expensive gases can achieve similar cut quality.
  - Poor cut quality on ferrous materials.
  - Provides faster cutting speeds and high cut quality on thicker materials to offset the higher cost.
  - A 65% argon / 35% hydrogen mixture should be used.
3. Nitrogen (N<sub>2</sub>) Plasma
  - Provides better cut quality on nonferrous materials such as stainless steel and aluminum.
  - Can be used in place of air plasma with air shield.
  - A good clean welding grade nitrogen should be used.

### B. Shield Gases

1. Compressed Air Shield
  - Air shield is normally used when operating with air or oxygen plasma.
  - Improves cut quality on some ferrous materials.
  - Inexpensive - reduces operating costs.
2. Nitrogen (N<sub>2</sub>) Shield
  - Nitrogen shield is used with nitrogen (N<sub>2</sub>) or Ar/H<sub>2</sub> (H35) plasma.
  - Provides smooth finishes on nonferrous materials.
  - May reduce smoke when used with Ar/H<sub>2</sub> plasma.

## 4.05 Power Supply Status Codes

**NOTE!**

See the Appendix for Advanced Troubleshooting.

On start-up and during operation, the power supply control circuitry performs various tests. If the circuitry detects a condition requiring operator attention, the status display on the front panel shows a 3 digit code preceded by either letter "E" (currently active fault) or letter "L" (last or latched fault) meaning a fault occurred stopping the process but is not currently active.

Some conditions can be active indefinitely, while others are momentary. The power supply latches momentary conditions; some momentary conditions can shut down the system. The indicator may show multiple conditions in sequence; it is important to recognize all possible conditions that may be displayed.

**NOTE!**

500 codes are not used for this system.

CCM Status Code		
Group 1 Plasma Process		
Code	Message	Remedy / Comments
101	Plasma Disabled	Plasma Enable Off ; External Disable activated or CCM TB1-1&2 jumper missing; 40 circuit ribbon cable from Relay PCB to CCM disconnected or defective;
102	Pilot Ignition Failure	Pilot did not start within 15 seconds. Torch consumable parts worn? Ensure current control setting matches consumables; Plasma pressure too high; Defective Arc Starter; Defective Pilot PCB; defective Inverter section 1A.
103	Lost Pilot	Pilot went out while Start active. Torch consumable parts worn? Ensure current control setting matches consumables; Plasma pressure too high;
104	Transfer Lost	Arc was transferred to work for more than 50 ms and then went out while Start still active. Arc lost contact with work, run off edge, over hole, etc.; Standoff too high; Ensure current control setting matches consumables; Wrong gas pressure
105	Not used	Reserved for legacy product
106	Pilot Timeout, no Transfer	Must transfer from Pilot to Cutting Arc in 0.085 seconds (SW8-1 OFF) or 3 sec. (SW8-1 ON). Standoff too high or void in work under torch; Current Control setting too low for consumables resulting in: Pilot current too low for consumables; Wrong gas pressure.
107	Tip Saver Fault	Tip remained in contact with work in excess of 15 seconds. ( Pak200i).
108	Tip to Electrode voltage fault.	Tip voltage too close to electrode voltage. Rear panel gas switch set to wrong gas; Torch consumable parts worn out; Wrong consumables installed causing tip to electrode short; Plasma pressure too low; Leak in Plasma hose to torch; Current Control set too high for consumables; Defective Pilot PCB; Shorted torch body .
109	Not used	Reserved for legacy product.
110	Not used	Reserved for legacy product.

CCM Status Code		
Group 2 -- Plasma Power Supply		
Code	Message	Remedy / Comments
201	Missing AC Phase	Blown fuse, Bad power cable connection; Defective System Bias PCB
202	Not used	Reserved for legacy product
203	Not used	Reserved for legacy product
204	Not used	Reserved for legacy product
205	DC Output Low	Less than 60 VDC; Negative lead short to work or ground; Defective inverter (output shorted); CCM voltage sense (J24) disconnected or wire broken; Defective CCM.
206	Not used	Reserved for legacy product
207	Unexpected current in work lead	Current above 8A in work lead prior to pilot ignition or transfer. Negative lead short to ground or arcstarter chassis; Defective HCT1 work lead current sensor; Defective Relay PCB.
208	Unexpected current in pilot circuit	Current above 6A in pilot circuit prior to ignition. Wrong or mismatched consumables causing tip - electrode short; Pilot lead shorted to negative in torch tube; Defective Relay PCB; Possible shorted torch.
209	Not used	Reserved for legacy product
210	Output Current Too High	Work lead current detected greater than 20% above process setting. Possible erroneous signal due to defective HCT1 Work lead current sensor or Relay PCB; Defective CCM.
211	Output Current Too Low	Work current detected more than 20% below process setting. Possible erroneous signal due to defective HCT1 Work lead current sensor or Relay PCB; Possible defective pilot PCB (shorted IGBT);
212	Inverter 1A Output Current Low	Plasma work current low during cutting and attributed to Inverter Module 1 Section A output low; Inverter output disconnected; Possible defective ribbon cable; If problem persists replace Inverter Module 1
213	Inverter 1B Output Current Low	Plasma work current low during cutting and attributed to Inverter Module 1 Section B output low; Inverter output disconnected; Possible defective ribbon cable; If problem persists replace Inverter Module 1
214	Inverter 2A Output Current Low	Plasma work current low during cutting and attributed to Inverter Module 2 Section A output low; Inverter output disconnected; Possible defective ribbon cable; If problem persists replace Inverter Module 2
215	Not Used	Reserved for other Systems
216	Inverter 3A Output Current Low	Plasma work current low during cutting and attributed to Inverter Module 3 Section A output low; Inverter output disconnected; Possible defective ribbon cable; If problem persists replace Inverter Module 3
217	Inverter 3B Output Current Low	Plasma work current low during cutting and attributed to Inverter Module 3 Section B output low; Inverter output disconnected; Possible defective ribbon cable; If problem persists replace Inverter Module 3
218	Inverter 1A Output Current High	Plasma work current high during cutting and attributed to Inverter Module 1 Section A output high; If problem persists replace Inverter Module 1
219	Inverter 1B Output Current High	Plasma work current high during cutting and attributed to Inverter Module 1 Section B output high; If problem persists replace Inverter Module 1
220	Inverter 2A Output Current High	Plasma work current high during cutting and attributed to Inverter Module 2 Section A output high; If problem persists replace Inverter Module 2
221	Inverter 2B Output Current High	Plasma work current high during cutting and attributed to Inverter Module 2 Section B output high; If problem persists replace Inverter Module 2
222	Inverter 3A Output Current High	Plasma work current high during cutting and attributed to Inverter Module 3 Section A output high; If problem persists replace Inverter Module 3
223	Inverter 3B Output Current High	Plasma work current high during cutting and attributed to Inverter Module 3 Section B output high; If problem persists replace Inverter Module 3

Code	Message	Remedy / Comments
224	Inverter 1 Not Found	Inverter Module 1 Section A required for Piloting; Ribbon cable CCM 1A to Inverter Module 1 Section A damaged or disconnected
225	Inverter 1A Incompatible Revision	Unsupported Inverter Revision; Ribbon cable CCM J31 to Inverter Module 1 Section A damaged; CCM code version incompatible with Inverter revision or model
226	Inverter 1B Incompatible Revision	Unsupported Inverter Revision; Ribbon cable CCM J32 to Inverter Module 1 Section B damaged ; CCM code version incompatible with Inverter revision or model
227	Inverter 2A Incompatible Revision	Unsupported Inverter Revision; Ribbon cable CCM J33 to Inverter Module 2 Section A damaged; CCM code version incompatible with Inverter revision or model
228	Not used	Reserved for other model with another inverter section
229	Inverter 3A Incompatible Revision	Unsupported Inverter Revision; Ribbon cable CCM J35 to Inverter Module 3 Section A damaged ; CCM code version incompatible with Inverter revision or model
230	Inverter 3B Incompatible Revision	Unsupported Inverter Revision; Ribbon cable CCM J36 to Inverter Module 3 Section B damaged ; CCM code version incompatible with Inverter revision or model
231	Inverter 1A VAC Mismatch	Inverter AC Voltage rating incompatible with Power Supply voltage rating; Ribbon cable CCM J31 to Inverter Module 1 Section B damaged or loose; Wrong voltage Inverter Module 1 installed; Defective Inverter module
232	Inverter 1B VAC Mismatch	Inverter AC Voltage rating incompatible with Power Supply voltage rating; Ribbon cable CCM J32 to Inverter Module 1 Section B damaged or loose; Wrong voltage Inverter Module 1 installed; Defective Inverter module
233	Inverter 2A VAC Mismatch	Inverter AC Voltage rating incompatible with Power Supply voltage rating; Ribbon cable CCM J33 to Inverter Module 2 Section A damaged or loose; Wrong voltage Inverter Module 2 installed; Defective Inverter module
234	Not used	Reserved for other model with another inverter section
235	Inverter 3A VAC Mismatch	Inverter AC Voltage rating incompatible with Power Supply voltage rating; Ribbon cable CCM J35 to Inverter Module 3 Section A damaged or loose; Wrong voltage Inverter Module 2 installed; Defective Inverter module
236	Inverter 3B VAC Mismatch	Inverter AC Voltage rating incompatible with Power Supply voltage rating; Ribbon cable CCM J36 to Inverter Module 3 Section B damaged or loose; Wrong voltage Inverter Module 3 installed; Defective Inverter module
237	Too Few Inverters Found	Two or more Inverter Sections required to operate; Ribbon cable from CCM to Inverter Section damaged or disconnected;
238	BIAS VAC Invalid	Invalid AC Voltage Selection; Damaged or loose connection at J61 of System Bias Supply
239	AC Voltage High	System Bias PCB detected AC Voltage is higher than Power Supply rated Voltage; System Bias Supply J61 Voltage Selection connection damaged or disconnected; Defective System Bias PCB; Defective CCM
240	AC Voltage Low	System Bias PCB detected AC Voltage is lower than Power Supply rated Voltage; System Bias Supply J61 Voltage Selection connection damaged or disconnected; Defective System Bias PCB; Defective CCM
241	Inverter 1A Input Voltage Error	Inverter Input Voltage fault; voltage out of range or missing phase at AC Input of Inverter Module 1 Section A; Poor AC Power Quality; Defective W1 contactor; Loose or open connection between input terminals and W1 contactor or contactor and input of Inverter Section; Defective Inverter module
242	Inverter 1B Input Voltage Error	Inverter Input Voltage fault; voltage out of range or missing phase at AC Input of Inverter Module 1 Section B; Poor AC Power Quality; Defective W1 contactor; Loose or open connection between input terminals and W1 contactor or contactor and input of Inverter Section; Defective Inverter module
243	Inverter 2A Input Voltage Error	Inverter Input Voltage fault; voltage out of range or missing phase at AC Input of Inverter Module 2 Section A; Poor AC Power Quality; Defective W1 contactor; Loose or open connection between input terminals and W1 contactor or contactor and input of Inverter Section; Defective Inverter module

Code	Message	Remedy / Comments
244	Not used	Reserved for other model with another inverter section
245	Inverter 3A Input Voltage Error	Inverter Input Voltage fault; voltage out of range or missing phase at AC Input of Inverter Module 3 Section A; Poor AC Power Quality; Defective W2 contactor; Loose or open connection between input terminals and W2 contactor or contactor and input of Inverter Section; Defective Inverter module
246	Inverter 3B Input Voltage Error	Inverter Input Voltage fault; voltage out of range or missing phase at AC Input of Inverter Module 3 Section B; Poor AC Power Quality; Defective W2 contactor; Loose or open connection between input terminals and W2 contactor or contactor and input of Inverter Section; Defective Inverter module
247	Inverter 1A Circuit Fault	Inverter Module 1 Section A detected a circuit fault; Damaged Inverter Module 1
248	Inverter 1B Circuit Fault	Inverter Module 1 Section B detected a circuit fault; Damaged Inverter Module 1
249	Inverter 2A Circuit Fault	Inverter Module 2 Section A detected a circuit fault; Damaged Inverter Module 2
250	Not used	Reserved for other model with another inverter section
251	Inverter 3A Circuit Fault	Inverter Module 3 Section A detected a circuit fault; Damaged Inverter Module 3
252	Inverter 3B Circuit Fault	Inverter Module 3 Section B detected a circuit fault; Damaged Inverter Module 3
253	Inverter 1A Over Temp Ambient	Inverter circuitry is over temperature likely cause is ambient greater than 40 deg C; Reduce power supply cutting Duty Cycle; Reduce ambient air temperature; Add auxiliary cooler.
254	Inverter 1B Over Temp Ambient	Inverter circuitry is over temperature likely cause is ambient greater than 40 deg C; Reduce power supply cutting Duty Cycle; Reduce ambient air temperature; Add auxiliary cooler.
255	Inverter 2A Over Temp Ambient	Inverter circuitry is over temperature likely cause is ambient greater than 40 deg C; Reduce power supply cutting Duty Cycle; Reduce ambient air temperature; Add auxiliary cooler.
256	Not used	Reserved for other model with another inverter section
257	Inverter 3A Over Temp Ambient	Inverter circuitry is over temperature likely cause is ambient greater than 40 deg C; Reduce power supply cutting Duty Cycle; Reduce ambient air temperature; Add auxiliary cooler.
258	Inverter 3B Over Temp Ambient	Inverter circuitry is over temperature likely cause is ambient greater than 40 deg C; Reduce power supply cutting Duty Cycle; Reduce ambient air temperature; Add auxiliary cooler.
259	Inverter 1A No Input Power	Inverter section may have no input power. Contactor not closed; Defective contactor or CB4 tripped; Inverter section input not connected; Defective Inverter.
260	Inverter 1B No Input Power	Inverter section may have no input power. Contactor not closed; Defective contactor or CB4 tripped; Inverter section input not connected; Defective Inverter.
261	Inverter 2A Over Temp Ambient	Inverter circuitry is over temperature likely cause is ambient greater than 40 deg C; Reduce power supply cutting Duty Cycle; Reduce ambient air temperature; Add auxiliary cooler.
262	Inverter 2B Over Temp Ambient	Inverter circuitry is over temperature likely cause is ambient greater than 40 deg C; Reduce power supply cutting Duty Cycle; Reduce ambient air temperature; Add auxiliary cooler.
263	Inverter 3A Over Temp Ambient	Inverter circuitry is over temperature likely cause is ambient greater than 40 deg C; Reduce power supply cutting Duty Cycle; Reduce ambient air temperature; Add auxiliary cooler.

Code	Message	Remedy / Comments
264	Inverter 3B Over Temp Ambient	Inverter circuitry is over temperature likely cause is ambient greater than 40 deg C; Reduce power supply cutting Duty Cycle; Reduce ambient air temperature; Add auxiliary cooler.
265	Inverter 1A No Input Power	Inverter section may have no input power. Contactor W1 not closed; Defective contactor or CB4 tripped; Inverter section input not connected; Defective Inverter.
266	Inverter 1B No Input Power	Inverter section may have no input power. Contactor W1 not closed; Defective contactor or CB4 tripped; Inverter section input not connected; Defective Inverter.
267	Inverter 2A No Input Power	Inverter section may have no input power. Contactor W1 not closed; Defective contactor or CB4 tripped; Inverter section input not connected; Defective Inverter.
268	Inverter 2B No Input Power	Inverter section may have no input power. Contactor W2 not closed; Defective contactor or CB4 tripped; Inverter section input not connected; Defective Inverter.
269	Inverter 3A No Input Power	Inverter section may have no input power. Contactor W2 not closed; Defective contactor or CB4 tripped; Inverter section input not connected; Defective Inverter.
270	Inverter 3B No Input Power	Inverter section may have no input power. Contactor W2 not closed; Defective contactor or CB4 tripped; Inverter section input not connected; Defective Inverter.
271	Inverter ID reading fault	CCM found ID values inconsistent during reading. CCM to an Inverter section ribbon damaged or disconnected; Improper ribbon cable routing.

CCM Status Code		
Group 3 -- Gas Controller Status & Protocol		
Code	Message	Remedy / Comments
301	Not used	Reserved for other models.
302	Reserved	No information available; Contact customer service
303	Gas Supply Pressure out of range.	Autocut is in SET mode or Plasma gas pressure is too low; Defective gas pressure sensor (PS1).
304	Gas Control Purging	Normal following power up or returning from Plasma Disable.
305	Not used	Reserved for other models.
306	Not used	Reserved for other future use.
307	Not used	Reserved for other models.
308	Gas Control Type Mismatch	Wrong CCM, must be Auto-cut type.
309	Not used	Reserved for other models.
310 *	DPC fault	Reserved for other models.
311 *	DPC valve control fault	Reserved for other models.
312 *	DMC fault	Reserved for other models.
313 *	Gas Controller not configured.	Reserved for other models.

\* Applies to DFC 3000 (Auto Gas) only

CCM Status Code		
Group 4 -- Torch Coolant System		
Code	Message	Remedy / Comments
401	Coolant Level low	Check coolant level, add as needed.
402	Low coolant flow	Coolant flow as measured by flow switch FS1 is less than 0.7 gpm (0.25 for Pak200i); Clogged filter; Restriction in torch lead or head; Wrong style consumables; Bad O-ring on the torch check valve; broken or defective torch coolant tube/check valve; Defective pump or bypass valve. 402 code along with 104 code is probably a low flow problem.
403	Coolant overheated	Coolant supply temperature exceeded 75 degrees Celcius (167 F). Operating with either lower side panel loose or removed; Coolant fan failed; radiator fins clogged with dirt.
404	Coolant System not ready.	Proper coolant flow of 0.7 gpm as measured by flow switch FS1 was not obtained during up to 4 minutes of Priming. New installation can require additional Priming cycle(s) to fill hoses with coolant; cycle power to restart Priming; Coolant hoses or torch hoses reversed; Clogged coolant filter; Restriction in torch lead or head; Wrong style consumables; broken or defective torch coolant tube/check valve; Defective pump or bypass valve.
405	Low Coolant Level Warning	Low coolant level during cut, does not stop cut. Add coolant as required.
406	Not used	Reserved for other models.
407	Coolant overheated, high ambient.	Allow unit to cool, allow longer time between cuts (reduced duty cycle) also refer to 403 code comments.



**NOTE!**  
There are no 500 codes.

CCM Status Code		
Group 6 -- CCM		
Code	Message	Remedy / Comments
601	Analog Voltage Error	Defective CCM, replace.
602	ADC or DAC error	Defective CCM, replace.
603	Reserved	No information available; Contact customer service
604	Data Memory error	Defective CCM, replace.
605	Program memory fault	Defective CCM, replace.
606	+5V Logic supply low	Defective CCM, replace.
607	Processor over temperature	Reduce ambient temperature; Defective CCM; replace
608	5V supply for RS 485/422 communication low.	Defective CCM, replace.
609	Firmware Update Device Error	Defective CCM; replace
610	Firmware Update Protocol Error	Defective CCM; replace
611	USB Controller Fault	Defective CCM; replace
612	USB Power Fault	Remove faulty USB device; Defective CCM
613	USB Log Creation Fault	Unable to create Log file on USB Flash drive last firmware update attempt; Use different USB Flash Drive or Reformat
614	No USF File	File VTCCMFV.USF missing from Flash Drive; Add proper files to Flash Drive for Firmware Update; Use different USB Flash Drive or Reformat
615	No CCM Update File	CCM Firmware file specified in VTCCMFV.USF not found ; Add proper files to Flash Drive for Firmware updating
616	DPC Update Fault	Fault occurred attempting to update DPC firmware; Add proper files to USB Flash drive for Firmware updating; Refer to CCM_LOG.TXT on Flash Drive for details
617	DMC Update Fault	Fault occurred attempting to update DMC firmware; Add proper files to USB Flash drive for Firmware updating; Refer to CCM_LOG.TXT on Flash Drive for details
618	ADC Calibration Fault	Error too large calibrating ADC; Fault persists defective CCM;
619	Flow Switch Fault	Flow switch reporting coolant flow when pump off;
620	Non Volatile Memory Error	Non Volatile Memory Storage Corrupted and Erased; Fault persists defective CCM.
621	USB Format Fault	A USB flash drive was detected but could not be read by CCM. Backup any files currently on flash drive, reformat the USB flash drive to a FAT or FAT32 file system, replace only the CCM update files and try again. Use different USB flash drive formatted with FAT or FAT32 file system.
622	CCM Code Execution Fault	Possible EMI noise problem or code fault. Check for proper grounding and bonding of equipment and routing of torch leads and cables to reduce Electromagnetic Emission Interference onto CCM module. If problem persists, verify CCM code version is the latest supported revision. Replace CCM module.

## SECTION 5: MAINTENANCE

### 5.01 General Maintenance

Perform the following checks periodically to ensure proper system performance.

	1 month	2 month	4 month	6 month	1 year	3 years	4 years	5 years
	80 arc hours	160 arc hours	320 arc hours	480 arc hours	960 arc hours	2880 arc hours	3840 arc hours	4800 arc hours
LUBRICATE CARTRIDGE O-RING	X							
LUBRICATE TORCH O-RING	X							
CARTRIDGE O-RING		X						
TORCH O-RING		X						
DO A COOLANT FLOW TEST			X					
CLEAN RADIATOR			X					
WASH COOLANT FILTER CARTRIDGE			X					
REPLACE COOLANT LIQUID				X				
REPLACE H2O PUMP ACTIVE FILTER CARTRIDGE				X				
TORCH COOLANT TUBE				X				
REPLACE CARTRIDGE				X				
CHECK FOR COOLANT LEAKS				X				
CHECK FOR GAS LEAKS				X				
TIGHTEN RAS CABLE CONNECTION				X				
REPLACE COOLANT FILTER CARTRIDGE					X			
REPLACE TORCH HEAD						X		
REPLACE TORCH LEAD SET							X	
REPLACE GAS LEAD SET								X

### 5.02 Coolant Filter Cleaning Procedure

Periodic cleaning of the coolant filter ensures maximum coolant flow efficiency. Poor coolant flow causes inefficient torch parts cooling with consequent faster consumable wear.

Clean the coolant filter as follows:

1. Disconnect system from main input power.
2. Unscrew and remove the filter canister by hand. Large canister located at the back of the power supply. Be sure to keep the O-ring.
3. Inspect and replace filter as needed. Re-install the canister, tightening it **by hand**. Be sure the O-ring is in place.
4. Turn the system on and check for leaks.

## 5.03 Coolant Replacement Procedure

Replace coolant as follows:

1. Disconnect the system from main input power.
2. Remove the lower right side panel.
3. Locate the coupling in the coolant line that comes from the bottom of the coolant tank, #1 in the following illustration. Disconnect the coolant line at this fitting and drain the coolant into a disposable container of sufficient size. Remember you will be draining more than the contents of the coolant reservoir.
4. Once coolant is draining, disconnect the gray hose coupling #2 in the illustration below. Allow excess coolant to drain, then apply a maximum of 5psi to clear the lines.



### CAUTION

Applying more than 5 psi air pressure to the cooling system will result in damage. Extra caution must be used when performing this task.

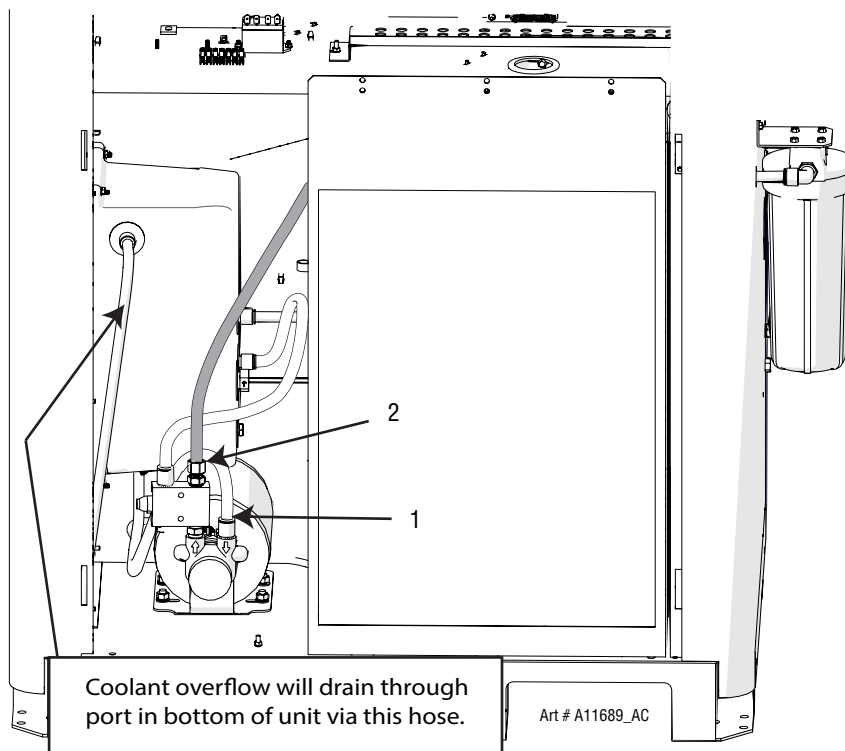

5. Reconnect those two fittings and then remove the filter bowl from the canister at the rear of the power supply. Pour this remaining coolant into the container and replace the filter bowl.



### NOTE!

If you also need to replace the coolant still in the leads, disconnect the leads from the power supply and manually drain them.

6. Fill the tank with fresh coolant until the right level is reached checking for leaks.
7. Turn system on, let it run for a few minutes and check coolant level, refill as needed. Refer to Section 3:16 Fill Cooling System on the procedure for this.

## 5.04 Arc Starter Service

Arc Starter Service Chart			
Symptom	Cause	Check	Remedy
No Pilot ignition: Spark in Arc Starter but no ignition	Coolant has become conductive	Use conductivity meter	Flush system, replace coolant.
	Pilot return wire not connected	Visual inspection	Connect Wire.
	Spark gap set too close	Check with feeler gauge	Set to 0.063" ±0.002"
	High Frequency cap (C4) possibly open	Use capacitance meter	Reconnect or replace.
	Broken or missing ferrites	Visual inspection	Replace.
	Short across in inductor (L1)	Visual inspection	Remove short; increase coil gaps.
	Spark gap bus caps (C1, C2, C3) broken or defective	Capacitance meter	Replace.
	Negative supply not connected correctly	Visual inspection	Reconnect.
No Pilot ignition: No Spark in Arc Starter	Spark gap set too large	Check with feeler gauge	Set to 0.063" ±0.002"
	Faulty transformer	Resistance measurement	Replace.
	No 120V supply	Check input voltage at EMI filter	Make connections; replace harness.
	No/ loose connection to spark gap	Visual inspection	Reconnect.
	Faulty EMI filter	Voltage/ Resistor measurement	Replace.
No cooling or insufficient cooling: Leaks coolant	Loose fitting(s)	Visual inspection	Tighten fittings.
	Failure to braze joints (L1)	Visual inspection	Replace HF Coil.
	Damaged or punctured coolant line(s).	Visual inspection	Replace coolant line(s).
No cooling or insufficient cooling: No Coolant Flow	Supply & return hose reversed	Visual Inspection of color-coded connections	Match coolant connection colors to arc starter fitting colors.
	Blockage in coil or supply/return hoses	Loosen fitting slightly and check for coolant flow	Flush system.
Erratic System Behavior (EMI Interference)	Torch Lead Shield not connected or loose. F1 gnd cable not connected.	Visual inspection of lead attachment to Arc Starter	Reconnect / tighten lead connectors.
	Missing or loose ground connection	Visual inspection of ground wire to Arc Starter	Make or tighten connections to good ground.
	Cap C5 not connected, open or loose	Visual inspection / capacitor measurement	Replace PCB.

## 5.05 Arc Starter Spark Gap Adjustment

1. Shut off input power. Remove the top console cover.
2. Adjust the spark gap as shown. Re-install the top cover.

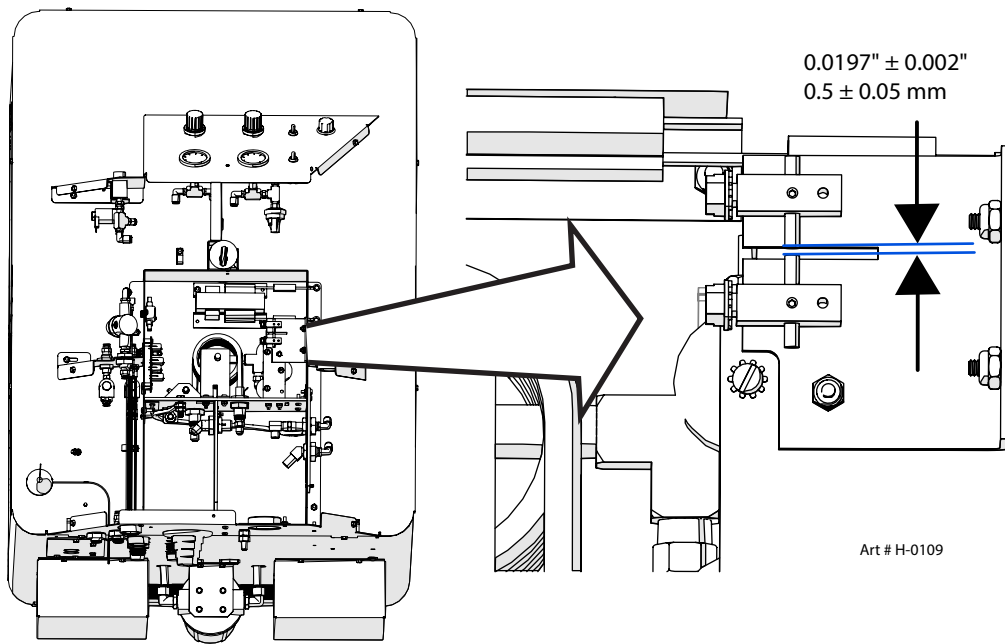

# SECTION 6: REPLACEMENT ASSEMBLIES & PARTS

## 6.01 Replacement Power Supply

Complete Unit / Component Catalog Numbers		Catalog Number
PAK 300i Power Supply,	480VAC + 10-15%	3-7113-2P
PAK 300i Power Supply with Torch and Coolant,	480VAC + 10-15%	1-7113-2P
PAK 300i Power Supply,	400VAC + 10-15% CE	3-7113-4P
PAK 300i Power Supply with Torch and Coolant,	400VAC + 10-15% CE	1-7113-4P
PAK 300i Power Supply,	400VAC + 10-15% Non CE	3-7113-3P
PAK 300i Power Supply with Torch and Coolant,	400VAC + 10-15% Non CE	1-7113-3P

## 6.02 Leads and Cables

Refer to section 3.05 for ground connections and ground cables.

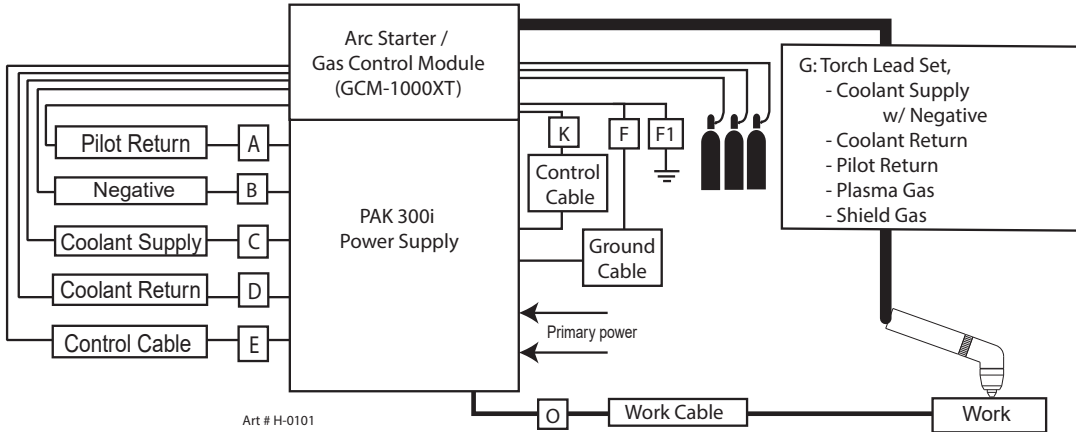

REPLACEMENT PARTS

Leads Catalog Numbers; PAK 300i Power Supply, PT-26P Torch												
Key	Description	Leads Length										
		3 ft 1 m	5 ft 1.52 m	10 ft 3.05 m	15 ft 4.5 m	25 ft 7.6 m	35 ft 10.6 m	50 ft 15.2 m	60 ft 18.3 m	75 ft 22.8 m	100 ft 30.5 m	125 ft 38.1 m
A,B,C,D,E	Supply Lead Set	4-3096		4-3097	4-3098	4-3099	4-3100	4-3101	4-3105	4-3102	4-3103	4-3104
A	Pilot Return Cable (4 ft / 1.2 m)		9-4890	9-4891	9-4790	9-4791	9-9426	9-4792	4-3200	9-4793	9-4794	9-4796
B	Negative Cable	9-7356		9-7357	9-7358	9-7359	9-7360	9-7361	4-3201	9-7362	9-7363	9-7364
C	Coolant Hose, Supply		9-4886	9-4887	9-4780	9-4782	9-4784	9-4786	4-3202	9-4787	9-4788	
D	Coolant Hose, Return		9-4888	9-4889	9-4762	9-4764	9-4766	9-4768	4-3203	9-4769	9-4770	
E	Control Cable, Power Supply to Arc Starter		9-4941	9-4916	9-4917	9-4918		9-4942	4-3204	9-4943	9-4944	9-4922
F	Ground Cable		9-4923		9-4924	9-4925		9-4926		9-4927	9-4928	9-4929
F1	Ground Cable, Gas to Earth		9-4931		9-4932	9-4933		9-4934		9-4935	9-4936	9-4937
G	Torch Lead Assembly					4-3044	4-3045	4-3046		4-3047	4-3048	
K	Control Cable, Power Supply to GCM 1000 XT		9-4907		9-4908	9-4909	9-9332	9-4910		9-4911	9-4912	9-4913
O	Work Cable				9-7350	9-7351		9-7352		9-7353		
P	Control Cable, CNC to Power Supply					9-7368		9-7369		9-7370	9-7371	9-7372

**NOTE!** Supply lead set includes Pilot Return Cable, Negative Cable, Coolant Supply & Return Hoses, and Control Cable.

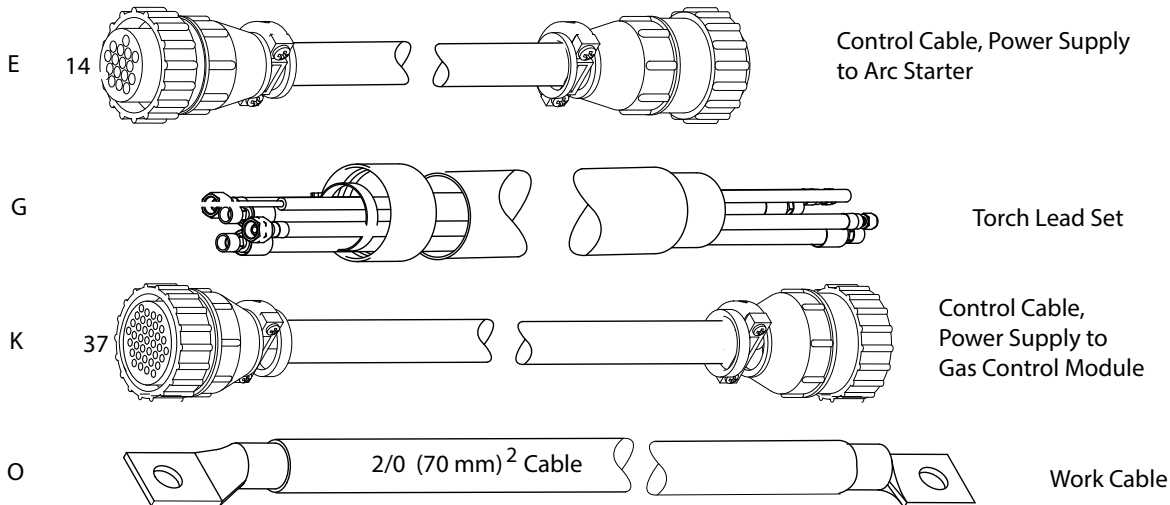

PT-26P Torch only for PAK 300i

Art # H-0107

6.03 Power Supply External Replacement Parts

Item #	Qty	Description	Catalog #
1	1	GCM 1000 XT Top Cover	9-7345
2	1	Power and Leads Cable Covers	9-7346
3	1	Lifting Eye, Cable	9-7347
4	1	Upper Side Covers (2 total)	9-7301
5	1	Lower Left Side Cover	9-7304
6	1	Lower Right Side Cover	9-7344

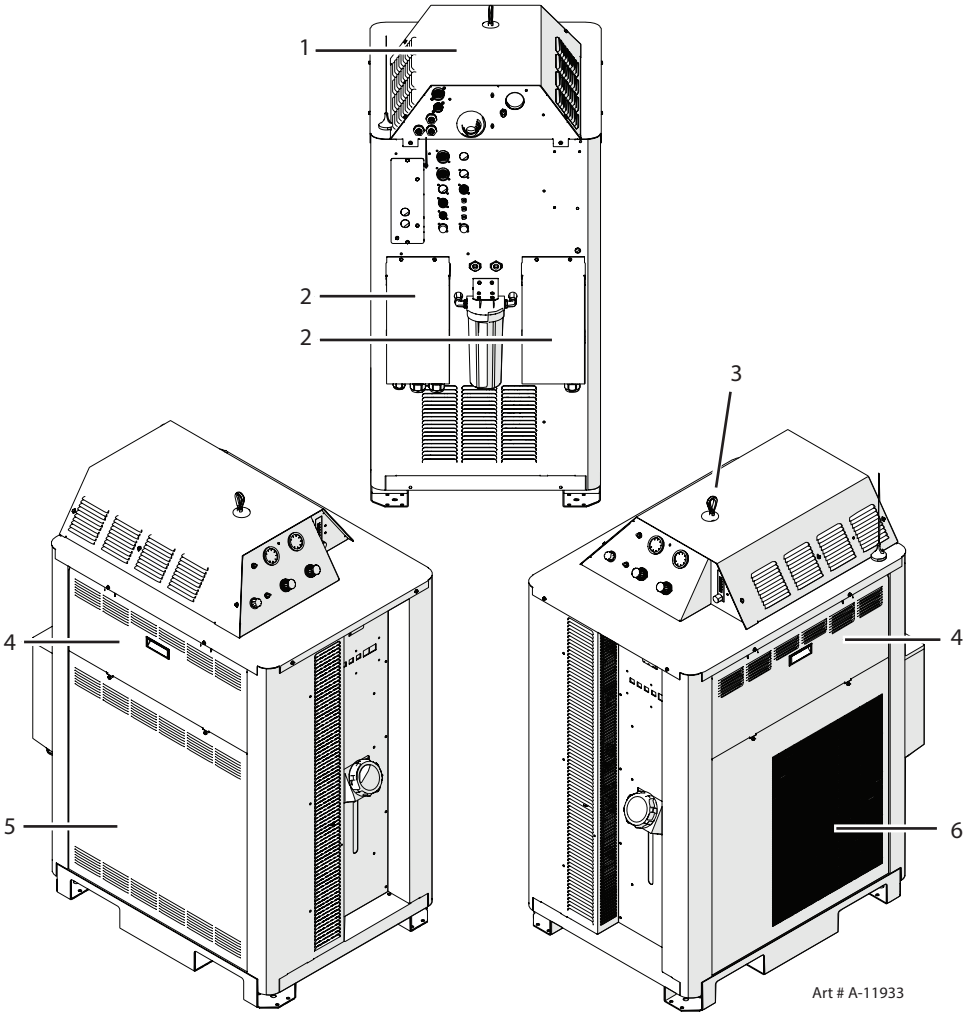

REPLACEMENT PARTS

**6.04 Power Supply Replacement Parts - Lower Right Side**

Item #	Qty	Description		Catalog #
1	1	Coolant Tank, Cap		8-5142
2	1	Coolant Tank		9-7306
3	1	Sensor, Coolant level		9-7307
4	1	Pump, Coolant, Assembly (with motor)		9-7309
	1	Pump, Coolant, Assembly (no motor)		9-7422
5	1	Motor, Pump (motor only)		9-7424
6	1	Heat Exchanger Fan	FAN1	9-7348
7	1	Radiator		9-7349
8	1	Flow, Switch (Not shown, behind cooling fan)	FS1	9-7310
9	1	Current Transducer, 300A (Not shown)	HCT1	W7005324

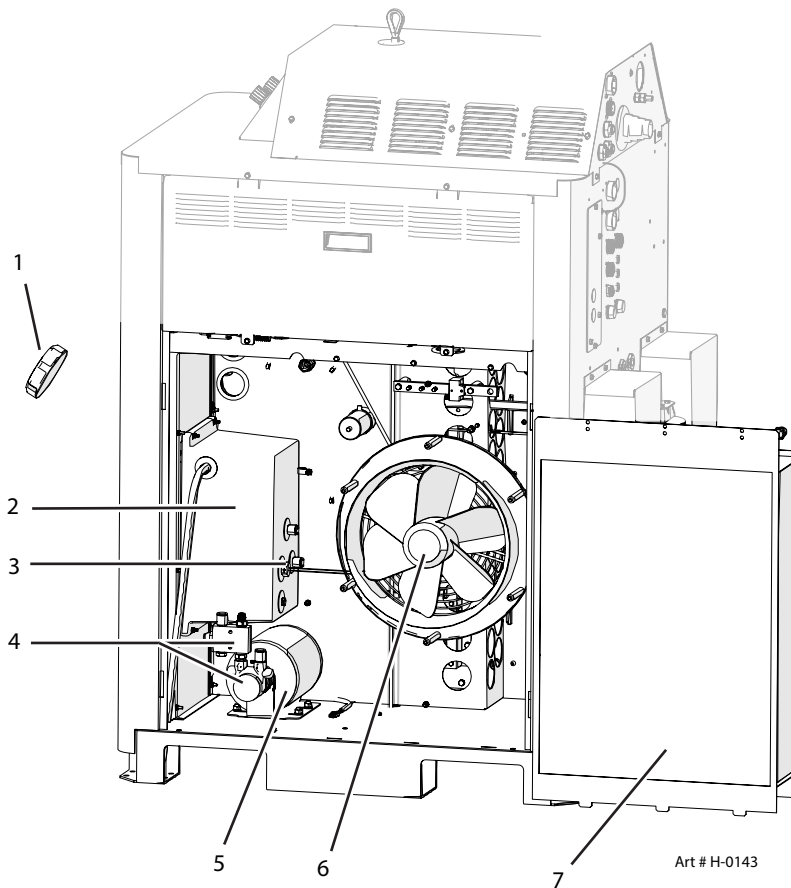

REPLACEMENT PARTS

6.05 Power Supply Replacement Parts - Upper Right Side

Item #	Qty	Description	Ref. Des.	Catalog #
1	1	Display PCB		9-9252
2	1	Auxilliary Transformer	T1	9-7315
3	1	On/Off Switch Breaker	CB1	9-7316
4	1	Fuse, 8A SB 500V (2 total)		9-7377
5	1	Bias Supply		9-9253
6	1	Relay and Interface PCB		9-9251
7	1	Pilot PCB Assembly		9-9250
8	1	CCM Assembly		9-7324
9	1	Inrush PCB		9-7327

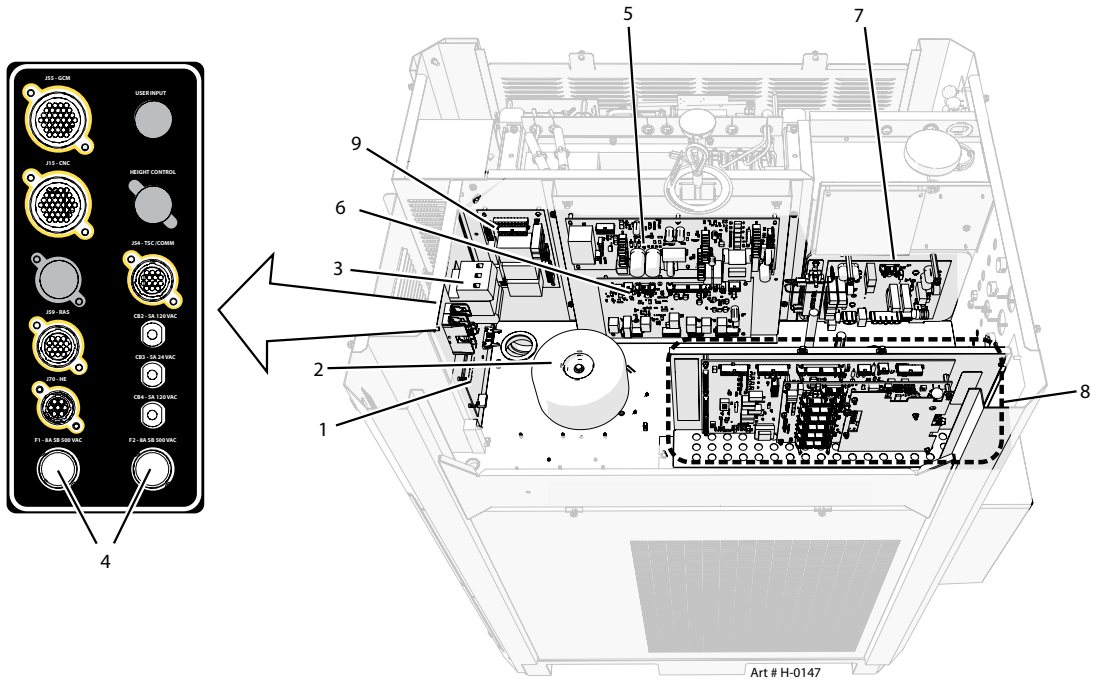

REPLACEMENT PARTS

**6.06 Power Supply Replacement Parts - Left Side**

Item #	Qty	Description	Ref. Des.	Catalog #
1	1	Suppressor PCB		9-9254
2	1	Main Contactor (2 total)	W1, W2	9-7318
3	1	Assy, Inverter, 3ph 380 - 400 VAC, 67A, XX1		9-9803
4	1	Assy, Inverter, 3ph 480 VAC, 67A, XX1		9-9802

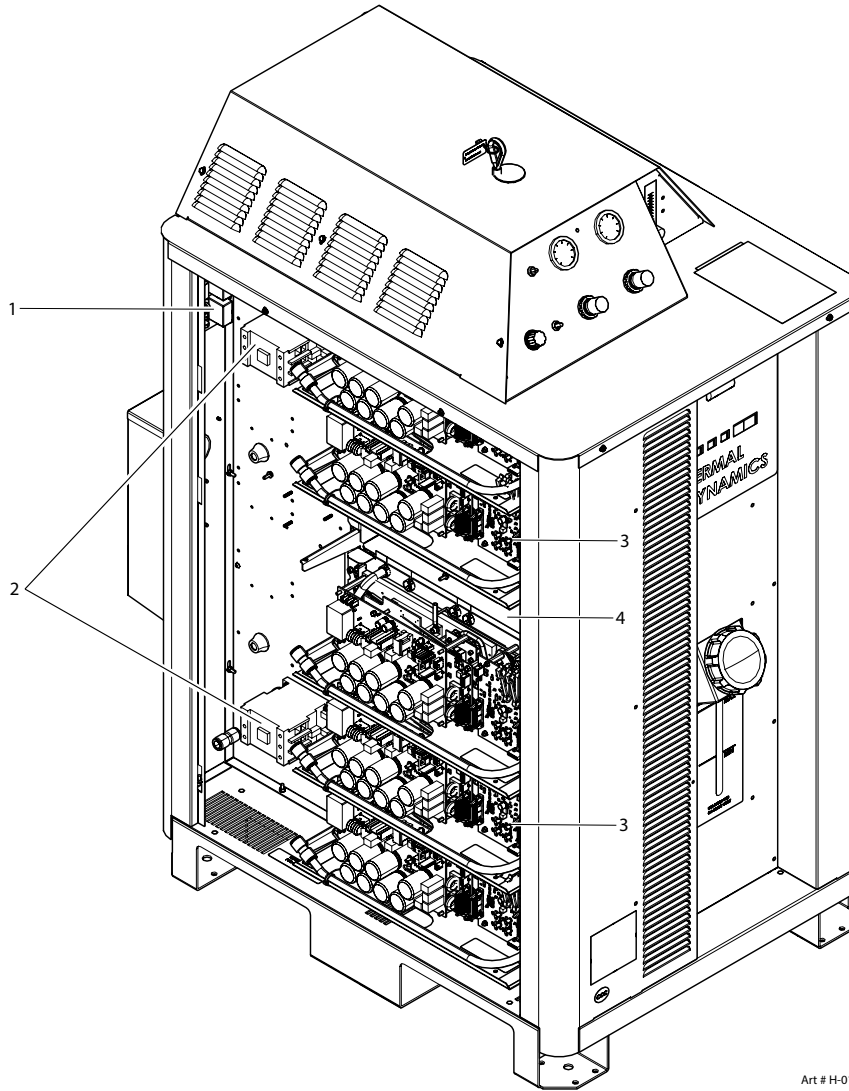

Art # H-0130

REPLACEMENT PARTS

6.07 Power Supply Replacement Parts RAS - GCM 1000 XT

Item #	Qty	Description	Ref. Des.	Catalog #
1	1	Gas Solenoid (3 required per unit)		9-6319
2	1	Water Filter Assembly		8-3460
3	1	HF Transformer		9-4959
4	1	Pressure Switch		9-6318
5	1	PCB, RAS1000 RF Cap Board		9-9423

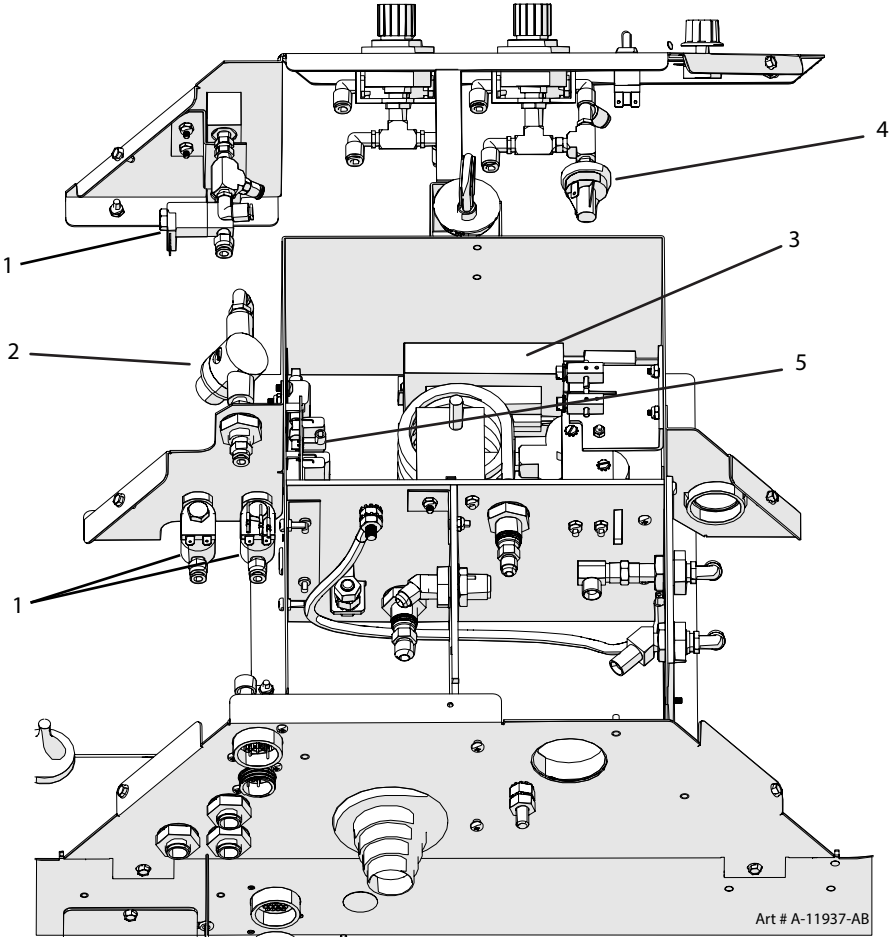

REPLACEMENT PARTS

**6.08 Power Supply Replacement Parts - Rear Panel**

Item #	Qty	Description	Breaker Rating	Circuit Rating	Ref. Des.	Catalog #
1	1	Coolant Filter Assy.				9-7320
2	1	Coolant Filter				9-7322
3	1	Gas Selection Switch				9-3325
*4	1	Air Filter Assembly AC200-XT				9-7527
		- First Stage Filter Element only				9-1021
		- Second Stage Filter Element only				9-1022

\* Not Shown

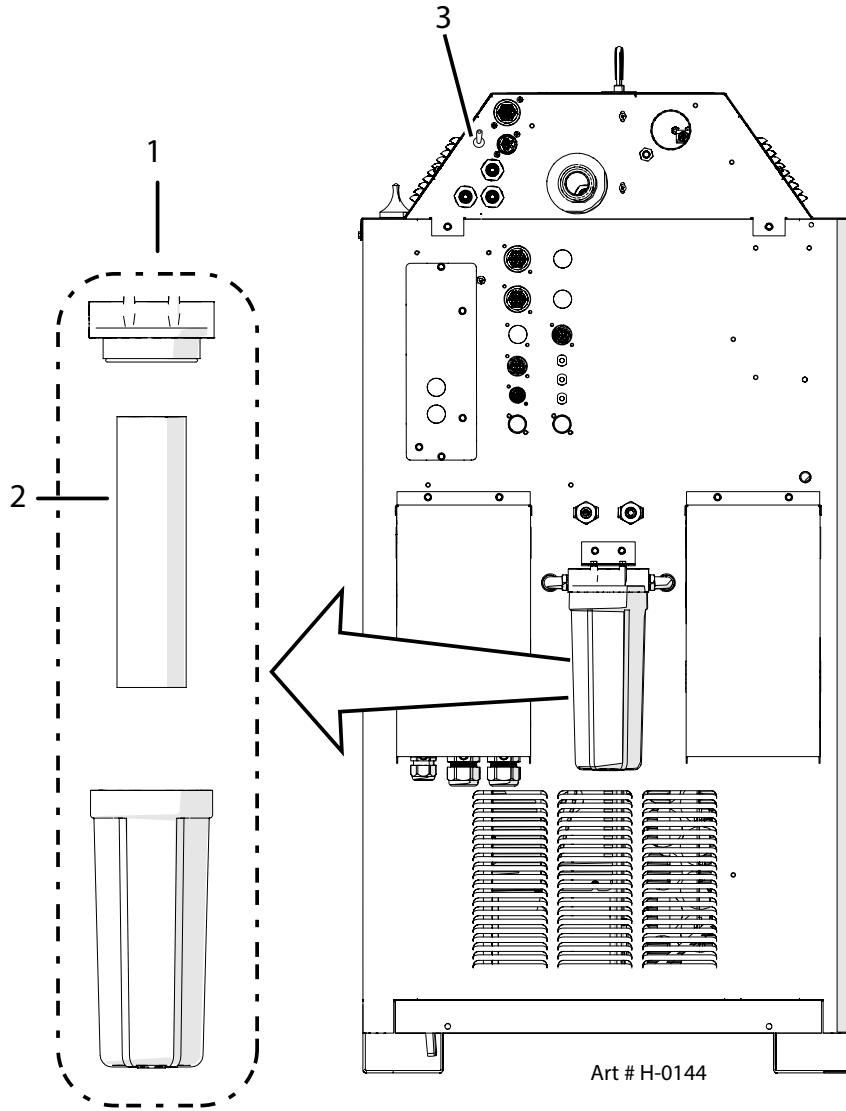

REPLACEMENT PARTS

6.09 Power Supply Replacement Parts - Front of GCM1000 XT

Item #	Qty	Description	Catalog #
1	1	Pressure Gauge	8-6800
2	1	Gas Regulator	9-9509
3	1	Run/Set Selector Switch	9-3426
4	1	Potentiometer with Knob	9-2685
5	1	Shield Gas Selector Switch	9-3427
6	1	Flowmeter, H <sub>2</sub> O (Not in use)	9-7762

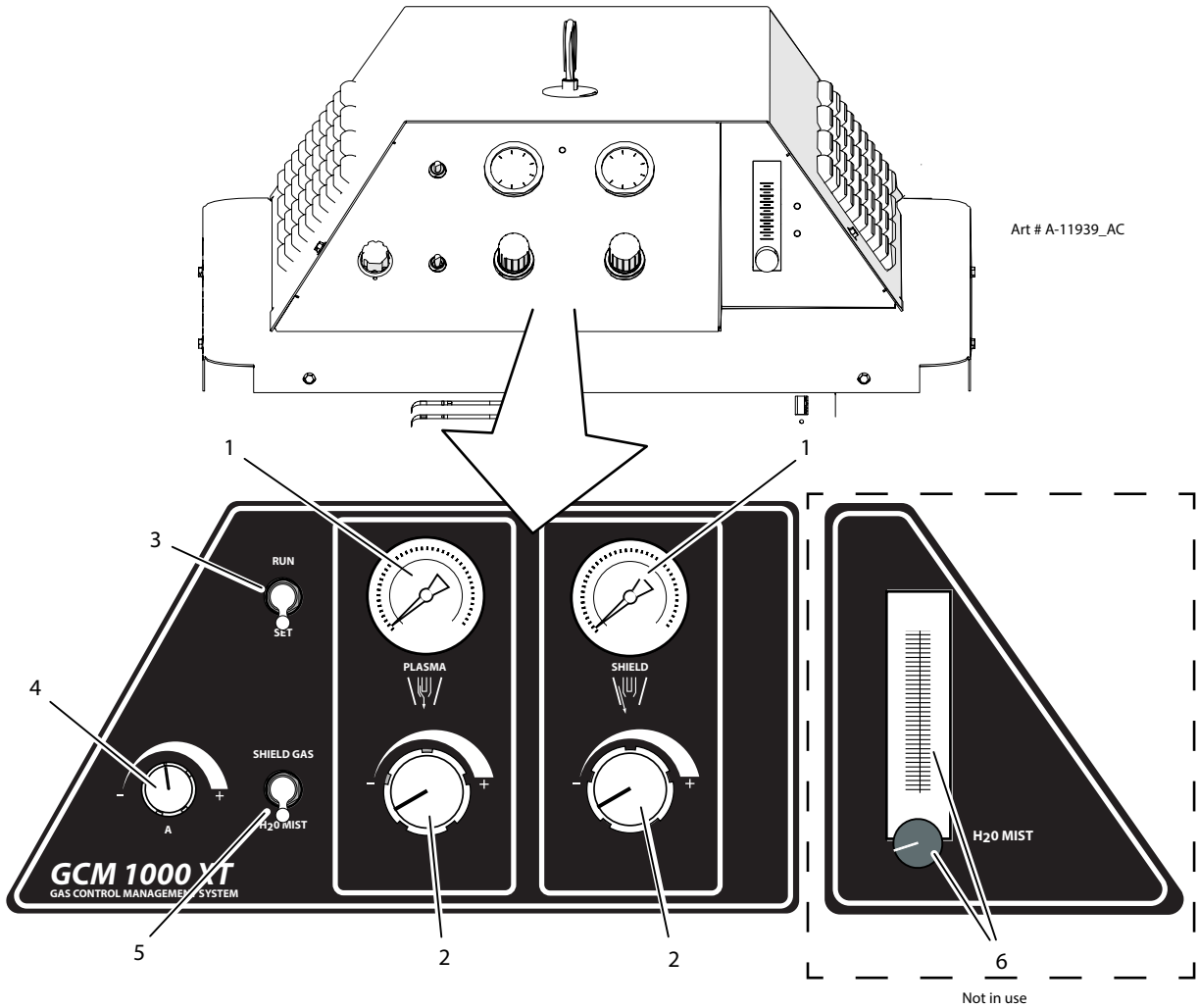

REPLACEMENT PARTS

**6.10 Recommended Gas Supply Hose**

<b>Item #</b>	<b>Qty</b>	<b>Description</b>	<b>Catalog #</b>
	1	3/8"Gray Synflex Hose. No fittings included. Catalog number per foot	9-3616

# APPENDIX 1: CNC CONTROL MODULE

## Control PCB Connections

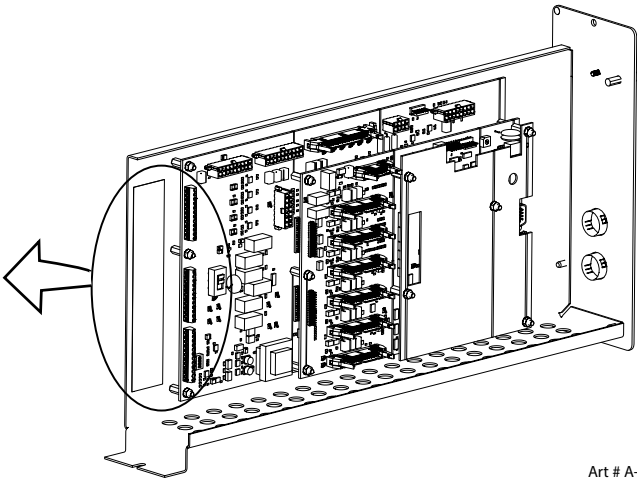
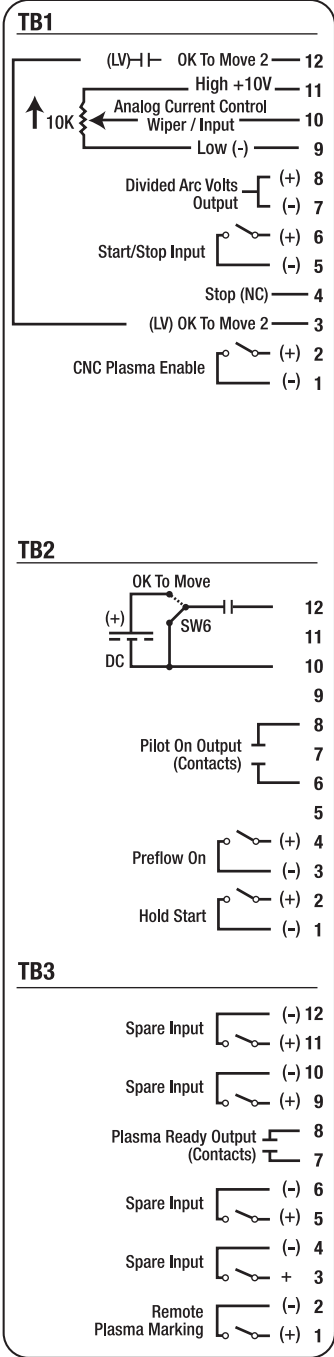

Art # A-11512\_AD

## Remote functions

### Remote Enable / Disable (input)

— Requires closed connection rated for 10 ma. @ 20VDC for unit to operate.

### Remote Start/Stop options

Factory installed jumper between TB1-1&2 must be removed when connecting user supplied Enable/Disable circuit. 4 Start/Stop (input)—Switch (momentary or sustained) minimum rating 10ma. @ 20 VDC

Start / Stop circuit configuration. Momentary Start / Stop (Latched) is only available at TB1.

SUSTAINED START / STOP

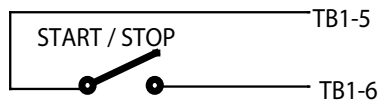

Art # H-0110

MOMENTARY START / STOP

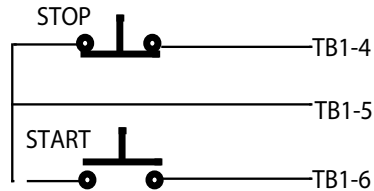

Remote Connections

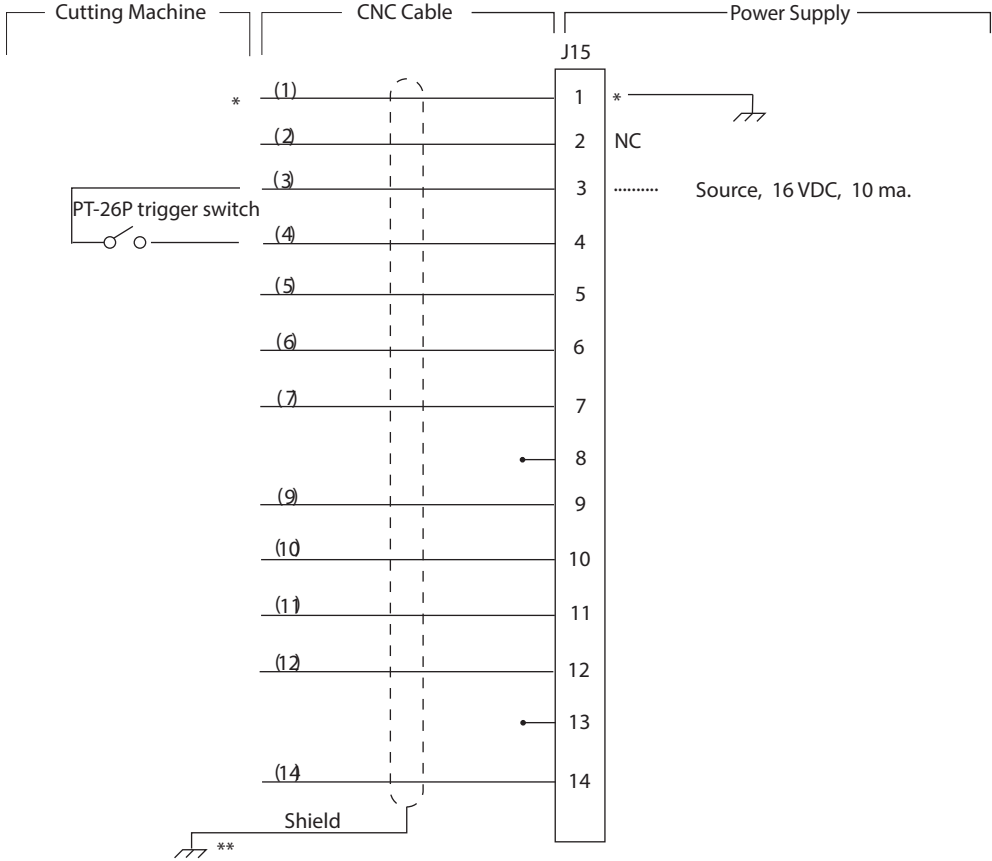

\* Power Supply Gnd not used for CNC cable  
Do not connect wire #1 to anything.

\*\* Cable Shield drain wire must be  
connected to ground at cutting machine.

Art # H-0145

# APPENDIX 2: CCM CPU PCB LAYOUT

▣ = Test Point

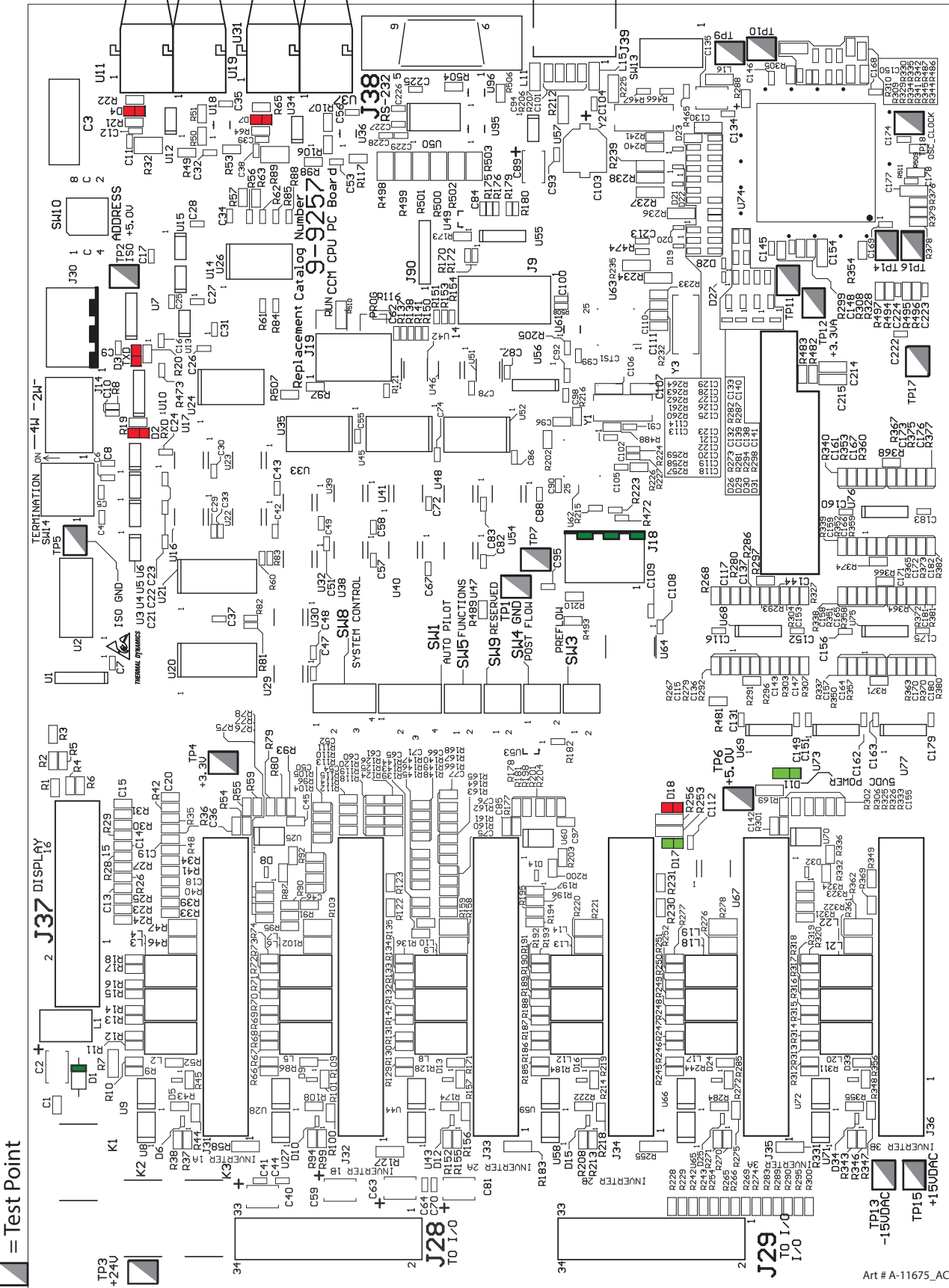

Art # A-11675\_AC

**CCM CPU PCB****Test Points**

TP1	GND
TP2	ISO +5.0V
TP3	+24V
TP4	+3.3V
TP5	ISO GND
TP6	+5.0V
TP7	TOTAL DEMAND 3.3V=400A
TP9	/WR
TP10	/RD
TP11	CPU TEMP SENSE
TP12	+3.3VA
TP13	-15VDAC
TP14	PC2
TP15	+15VDAC
TP16	CLKO
TP18	OSC_CLOCK

**LED Reference**

D2	Red	RXD
D3	Red	TXD
D4	Red	Fiber Out 2
D7	Red	Fiber Out 1
D11	Green	Future Use
D17	Green	Future Use

# APPENDIX 3: CCM I/O PCB LAYOUT

APPENDIX

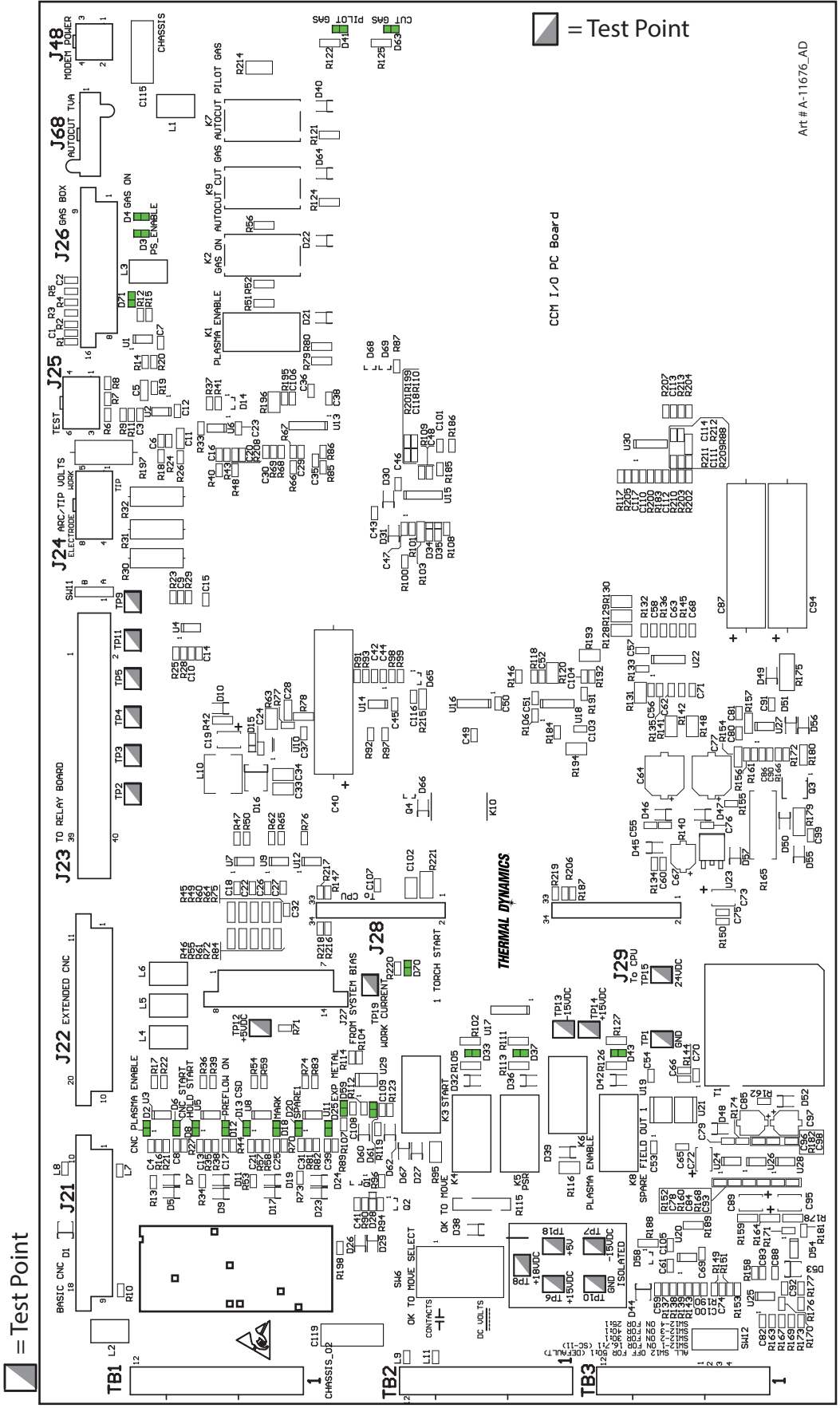

**CCM I/O PCB****J Connectors****Test Points**

TP1	GND
TP2	/COOLANT FANS ON
TP3	/TORCH PUMP ON
TP4	LOW COOLANT FLOW (SW)
TP5	COOLANT FLOW SIGNAL (PULSE)
TP6	+15V ISOLATED
TP7	-15V ISOLATED
TP8	+18V ISOLATED
TP9	ANALOG CURRENT CONTROL 0-3.3V
TP10	GND ISOLATED
TP11	/PILOT ENABLE
TP12	+5VDC
TP13	-15VDC
TP14	+15VDC
TP15	24VDC
TP18	+5V ISOLATED
TP19	WORK CURRENT

J21	BASIC CNC
J22	EXTENDED CNC
J23	RELAY - INTERFACE BOARD
J24	ARC / TIP VOLTS
J25	TEST
J26	GAS BOX
J28	TO CPU
J29	TO CPU

**LED Reference**

D2	Green	PLASMA ENABLE
D3	Green	E-STOP_PS
D4	Green	GAS ON
D6	Green	CNC START
D8	Green	HOLD START
D12	Green	PREFLOW ON
D13	Green	CSD
D18	Green	MARK
D20	Green	SPARE1
D25	Green	EXP METAL
D33	Green	OK TO MOVE
D37	Green	PSR
D41	Green	SPARE FIELD OUT 2
D43	Green	SPARE FIELD OUT 1

# APPENDIX 4: PILOT PCB LAYOUT

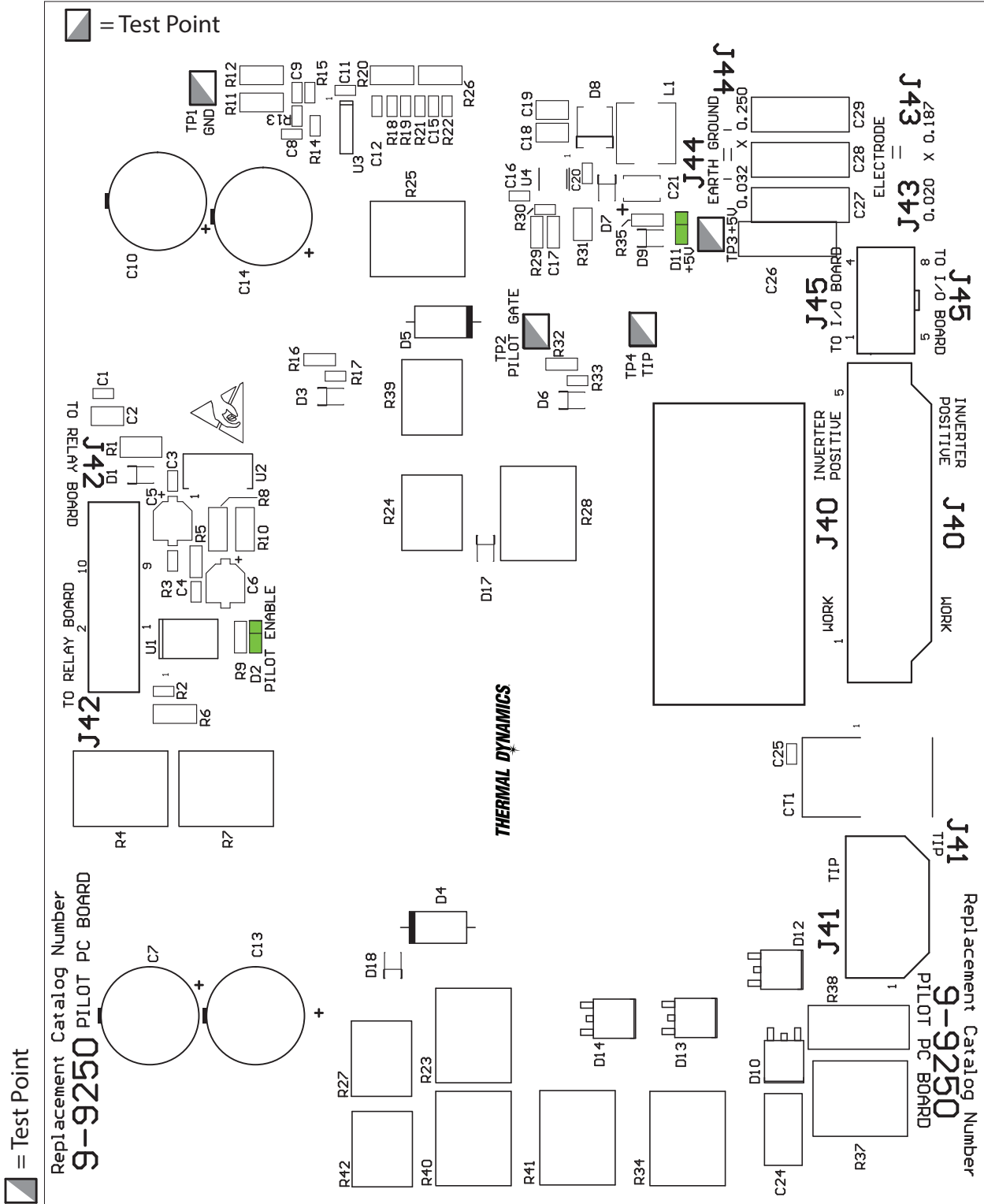

Art # A-11677\_AB

**Pilot PCB Test Points**

TP1	GND
TP2	PILOT GATE
TP3	+5V
TP4	TIP

**LED Reference**

D2	Green	PILOT ENABLE
D11	Green	+5V

# APPENDIX 5: RELAY AND INTERFACE PCB LAYOUT

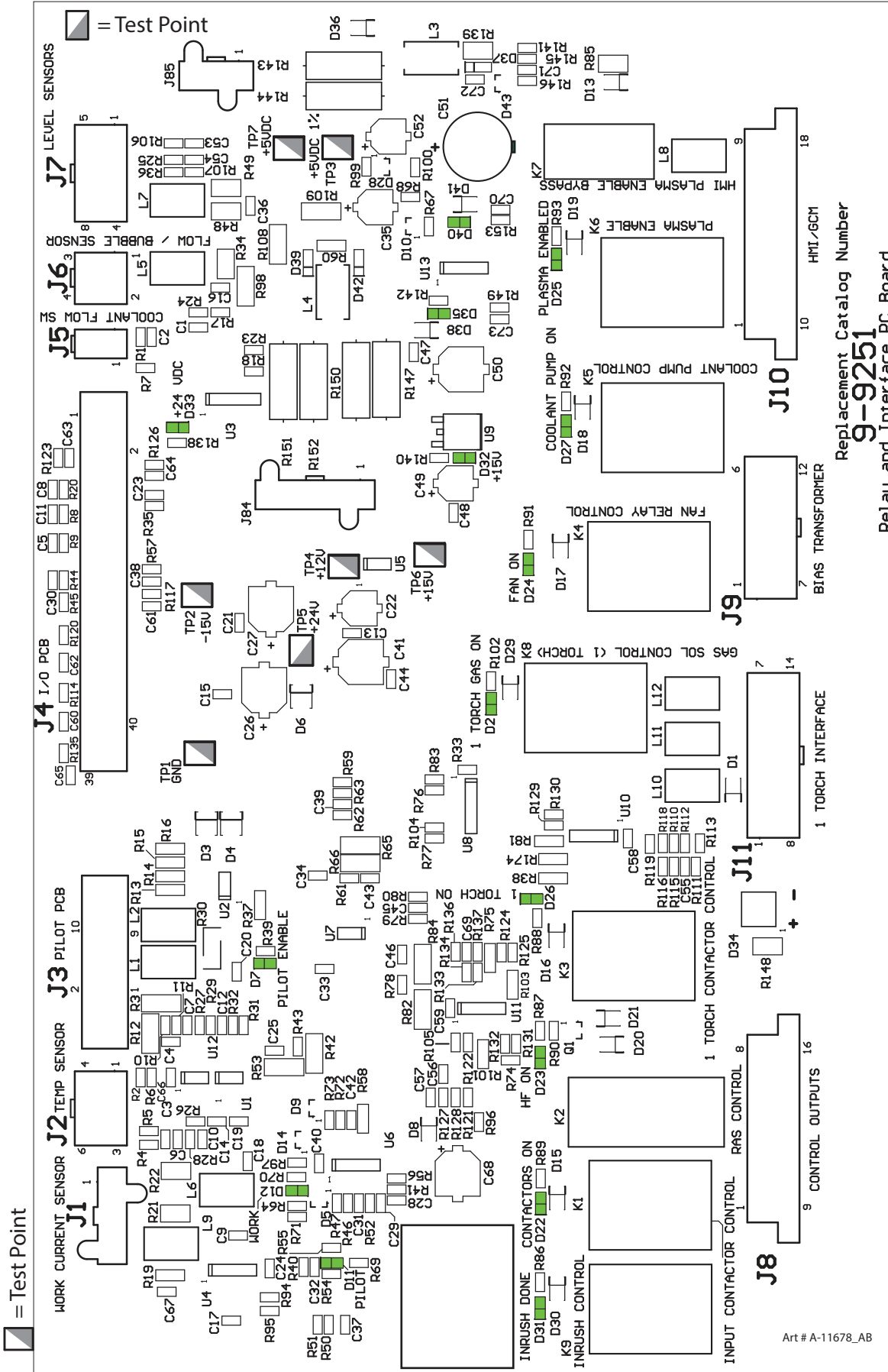

APPENDIX

**Relay and Interface PCB Test Points**

TP1	GND
TP2	-15V
TP3	+5VDC
TP4	+12V
TP5	+24V
TP6	+15V
TP7	+5VDC

**LED Reference**

D2	Green	1 TORCH GAS ON
D7	Green	PILOT ENABLE
D11	Green	PILOT CURRENT DETECTED
D12	Green	WORK CURRENT DETECTED
D22	Green	CONTACTORS ON
D23	Green	RF ON
D24	Green	FANS ON
D25	Green	PLASMA ENABLED
D26	Green	1 TORCH ON
D27	Green	TORCH COOLANT ON

# APPENDIX 6: DISPLAY PCB LAYOUT

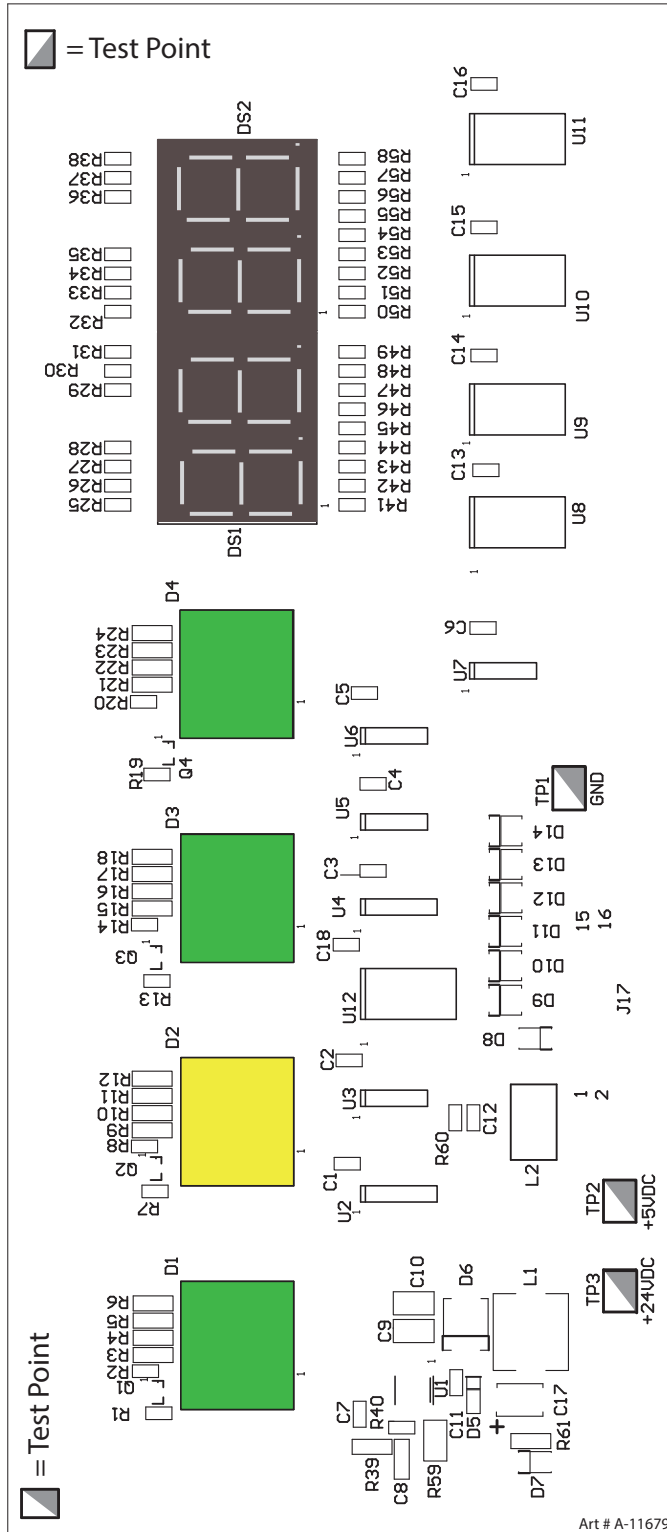

**Display PCB Test Points**

TP1	GND
TP2	+5VDC
TP3	+24VDC

# APPENDIX 7: SYSTEM BIAS PCB LAYOUT

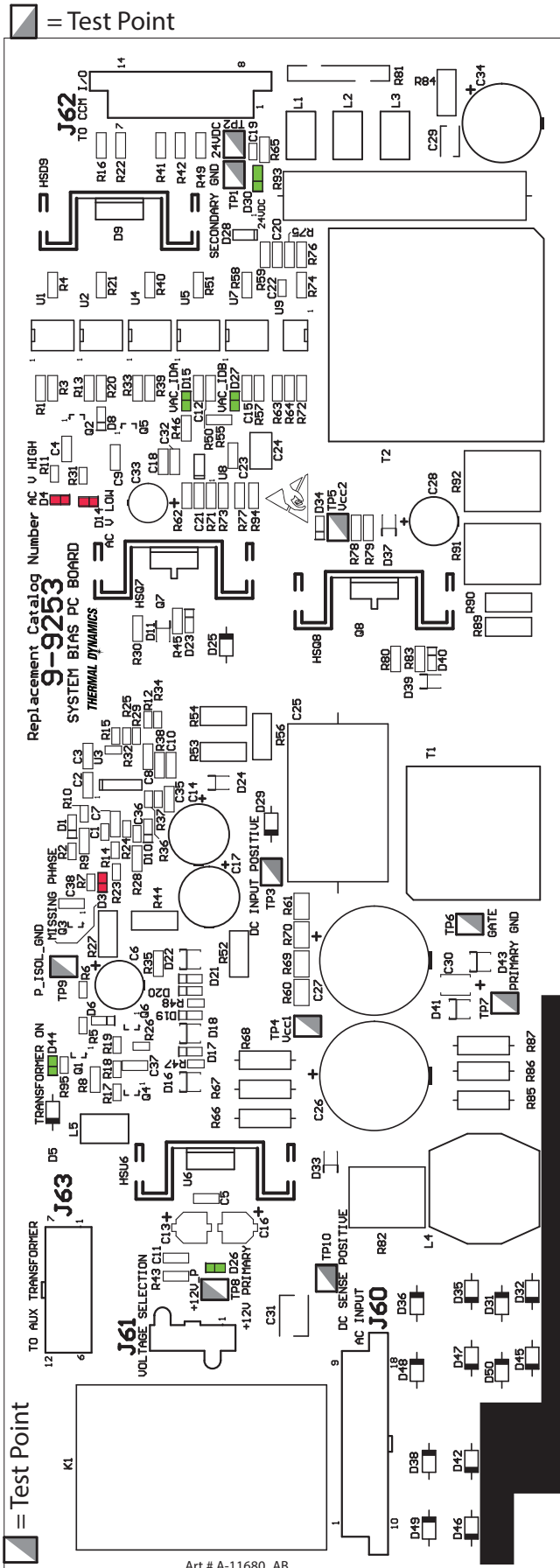

**System Bias PCB Test Points**

TP1	GND
TP2	24VDC
TP3	DC INPUT POSITIVE
TP4	Vcc1
TP5	Vcc2
TP6	GATE
TP7	PRIMARY GND
TP8	+12V PRIMARY
TP9	P_ISOL_GND
TP10	DC SENSE POSITIVE

**LED Reference**

D3	Red	MISSING PHASE
D4	Red	AC V HIGH
D14	Red	AC V LOW
D15	Green	VAC_IDA
D26	Green	+12V PRIMARY
D27	Green	VAC_IDB
D30	Green	24VDC
D44	Green	TRANSFORMER ON

# APPENDIX 8: MAIN INVERTER PCB LAYOUT

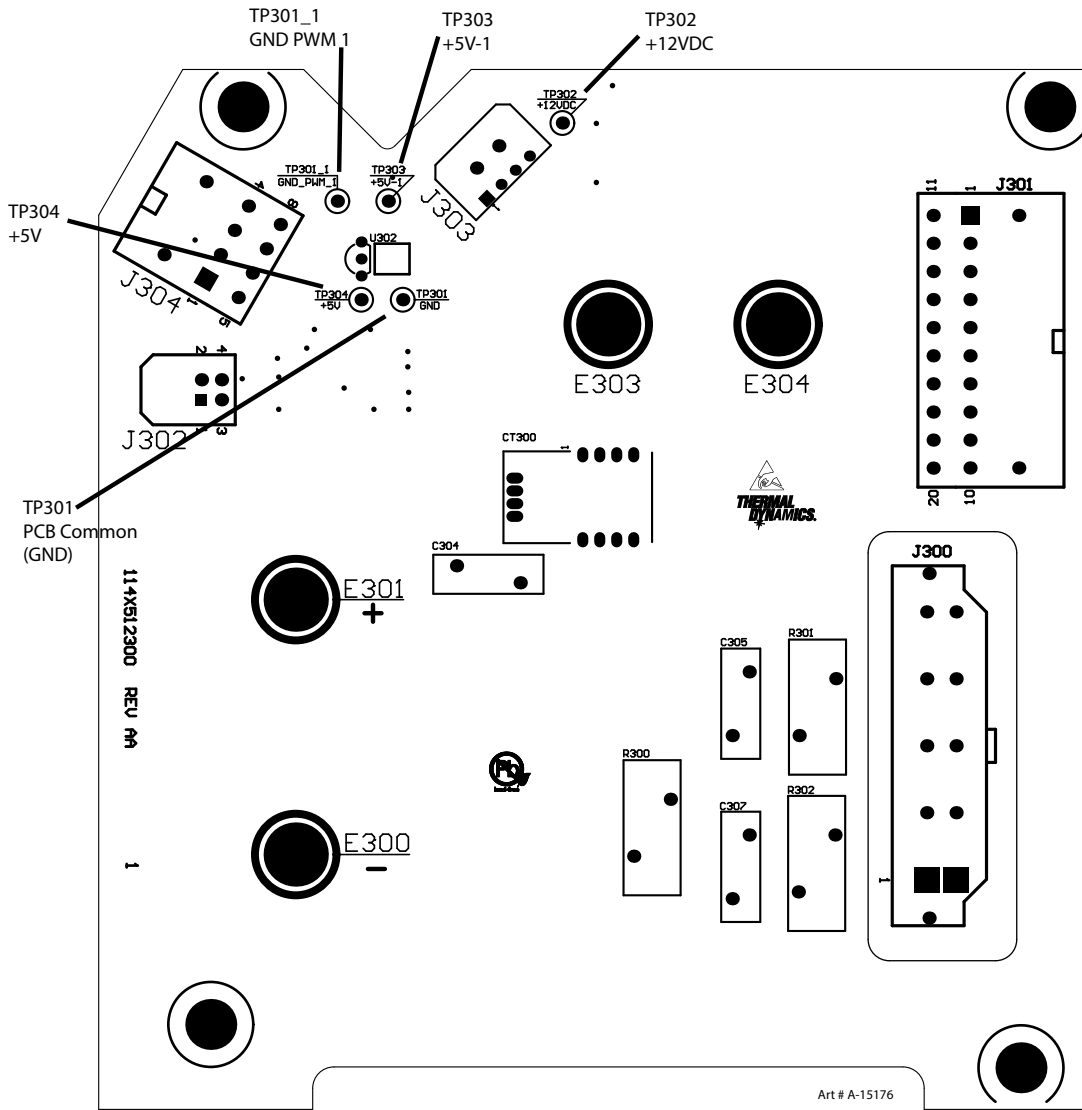

# APPENDIX 9: CONTROL AND FAULT PCB LAYOUT

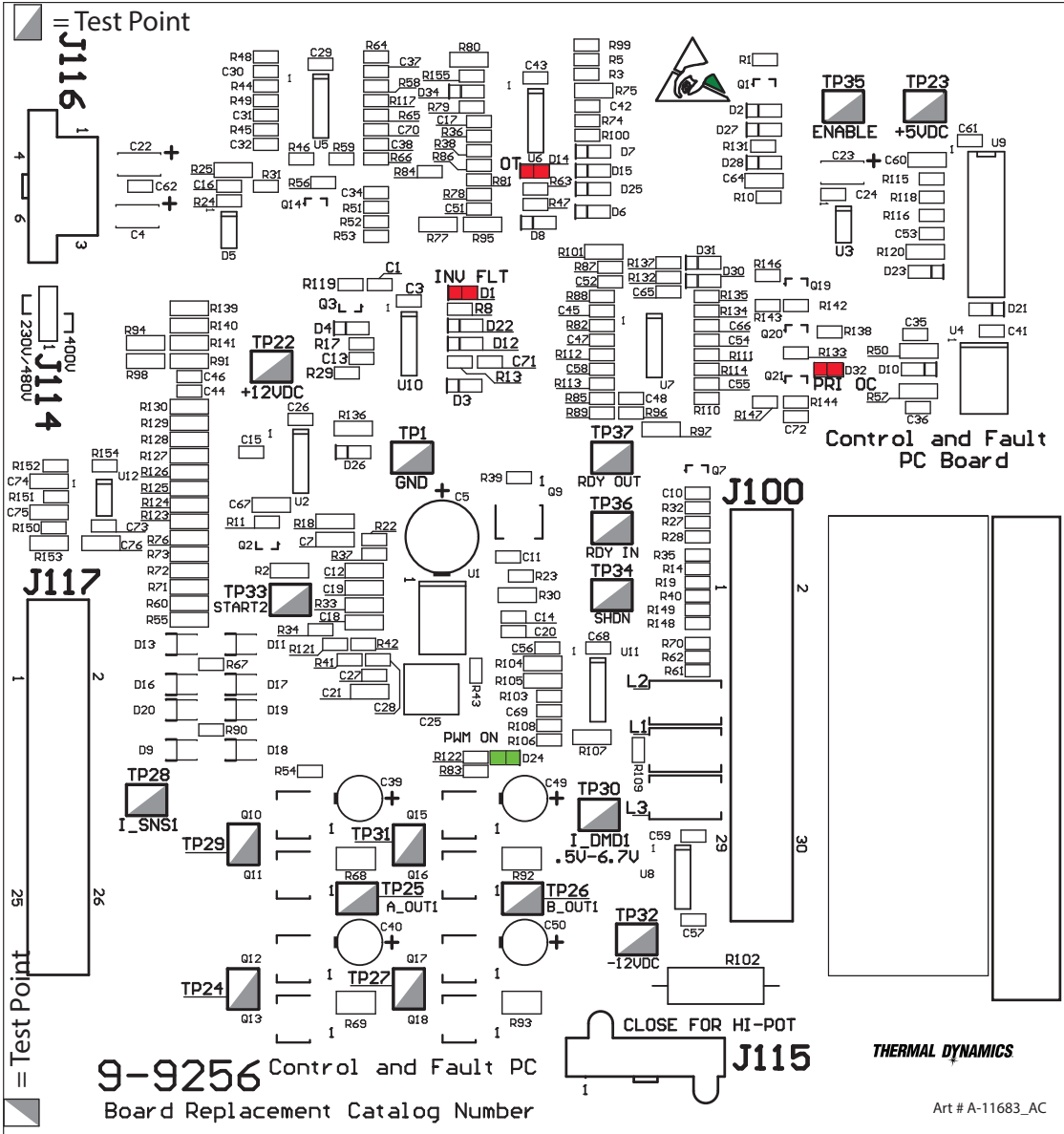

# PAK 300i

## Control and Fault PCB Test Points

TP1	GND
TP22	+12VDC
TP23	+5VDC
TP24	GATE 1+
TP25	A_OUT1
TP26	B_OUT1
TP27	GATE 1-
TP28	I_SNS1
TP29	GATE 2+
TP30	I_DMD1 0.5V-6.7V
TP31	GATE 2-
TP32	-12VDC
TP33	START 2
TP34	SHDN
TP35	ENABLE
TP36	READY IN
TP37	READY OUT

## LED Reference

D1	Red	INV FLT
D14	Red	OVER TEMP
D24	Green	PWM ON
D32	Red	PRI OC



# APPENDIX 11: SUPPRESSOR PCB LAYOUT

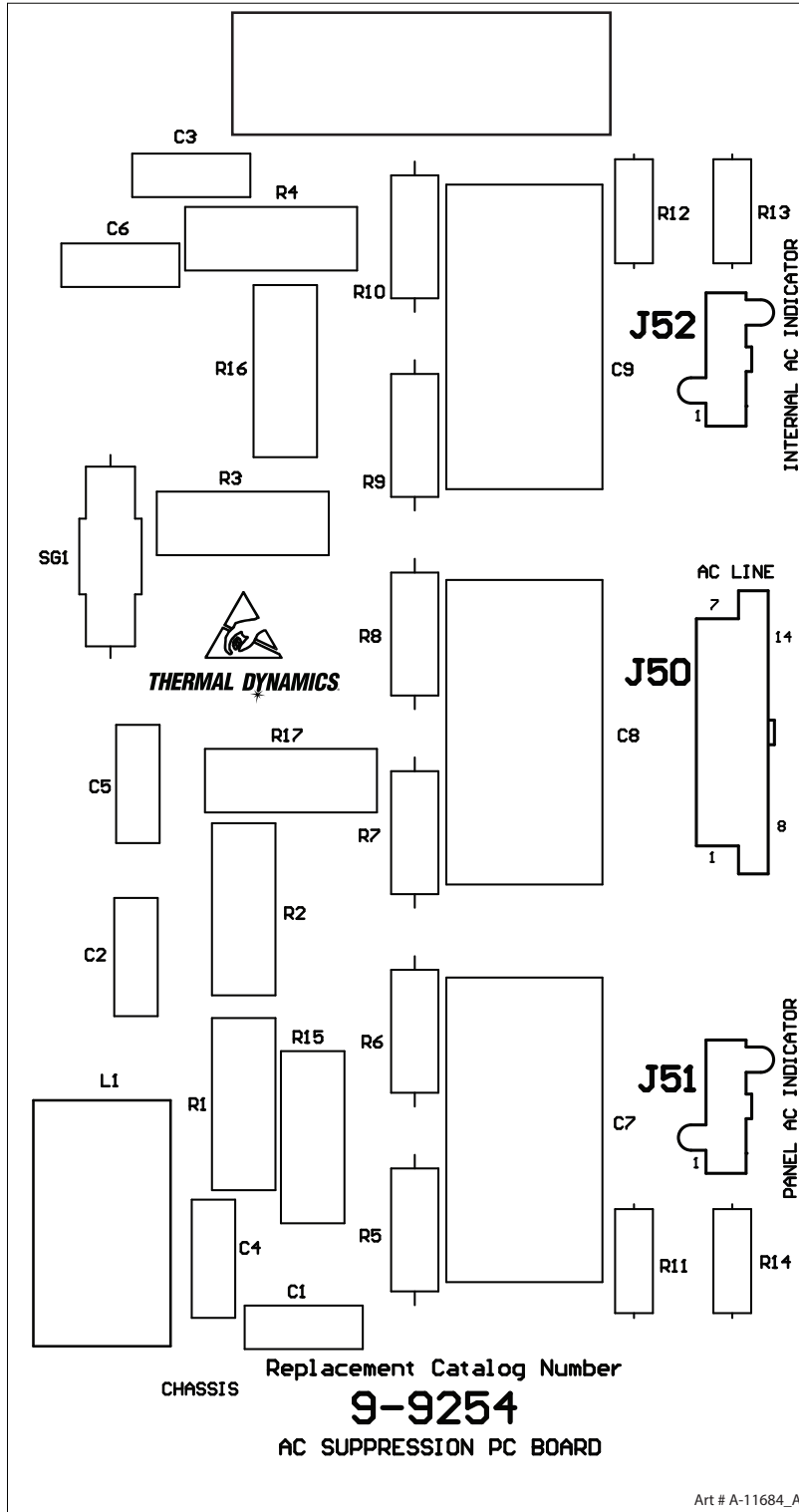

# APPENDIX 12: COOLING DIAGRAM

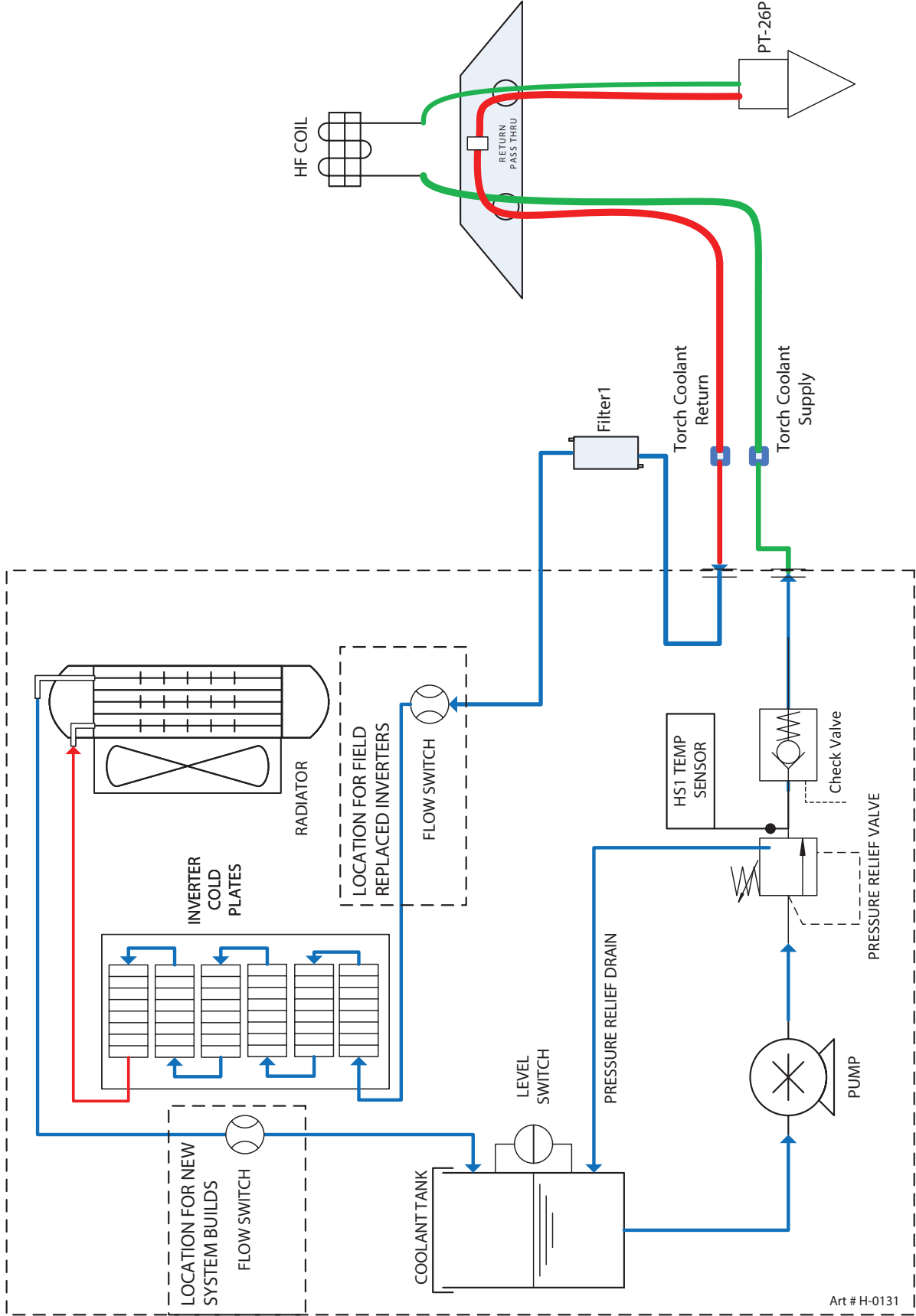

# APPENDIX 13: SYSTEM SCHEMATIC NON CE PG1

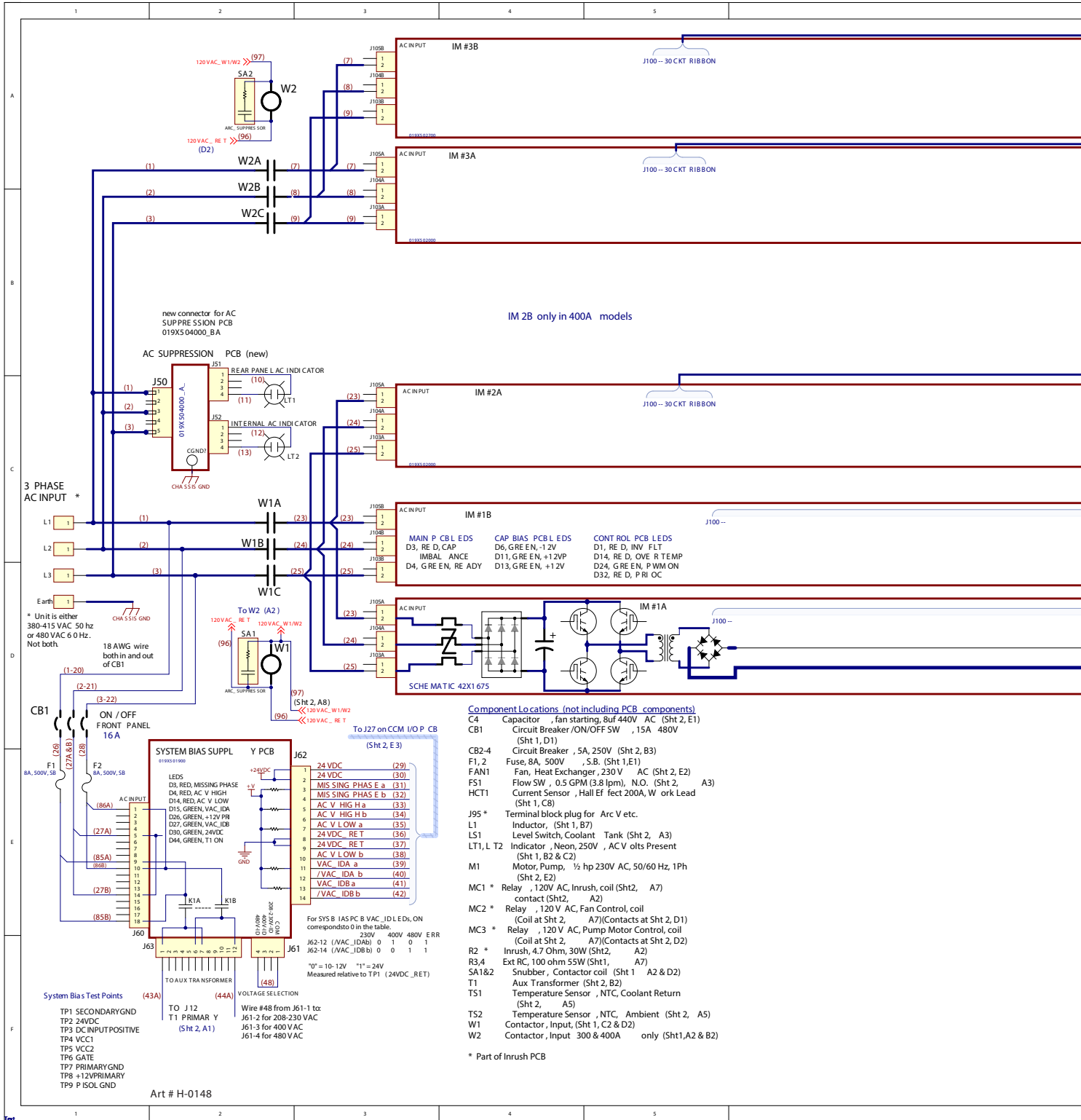

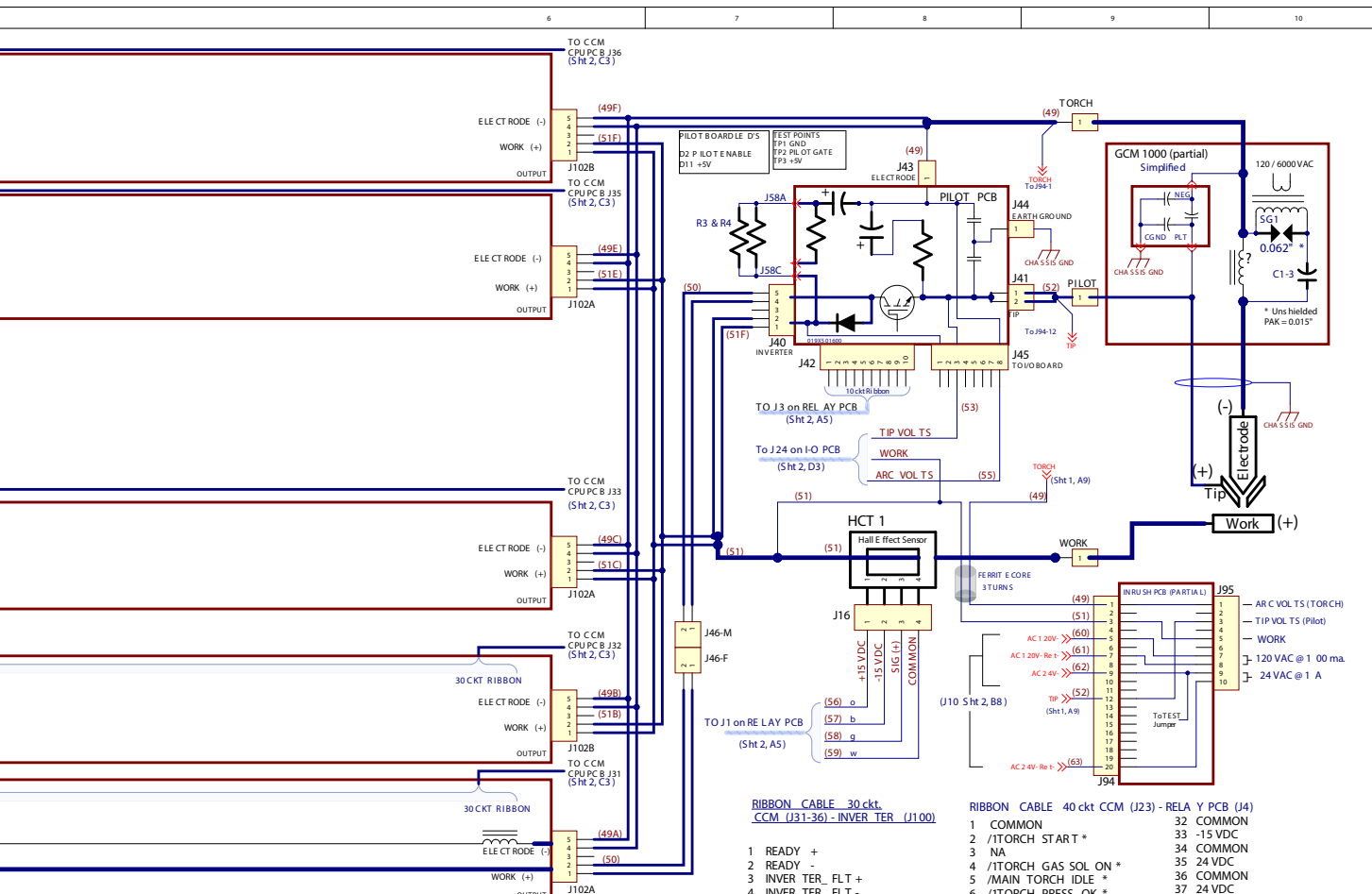

**RIBBON CABLE 30 ckt.**  
**CCM (J31-36) - INVERTER (U100)**

- 1 READY +
- 2 READY -
- 3 INVERTER\_FLT +
- 4 INVERTER\_FLT -
- 5 OVERTEMP\_FLT +
- 6 OVERTEMP\_FLT -
- 7 PWR\_PRESENT +
- 8 PWR\_PRESENT -
- 9 OUT\_COMM (+3 to 5VDC)
- 10 VAC\_SELA
- 11 VAC\_SELB
- 12 IS\_IDA
- 13 IS\_IDB
- 14 IS\_IDC
- 15 ENABLE +
- 16 ENABLE -
- 17 START2 +
- 18 START2 -
- 19 SPARE
- 20 SYNC\_IN +
- 21 SYNC\_IN -
- 22 NC
- 23 NC
- 24 47 OHM to COMM
- 25 DEMAND +
- 26 DEMAND -
- 27 47 OHM to COMM
- 28 CURRENT +
- 29 CURRENT -
- 30 47 OHM to COMM

**RIBBON CABLE 40 ckt CCM (J23) - RELAY PCB (J4)**

- 1 COMMON
- 2 /TORCH START +
- 3 NA
- 4 /TORCH GAS SOL ON +
- 5 /MAIN TORCH IDLE +
- 6 /TORCH PRESS OK +
- 7 FLOW SENSOR (pulses)
- 8 LOW COOLANT FLOW
- 9 COOLANT LEVEL OK
- 10 COMMON
- 11 NA
- 12 /PLASMA ENABLE-HMI
- 13 /COOLANT PUMP ON
- 14 COMMON
- 15 /PILOT ENABLE
- 16 /RAS ON
- 17 /CONTACTORS ON
- 18 COMMON
- 19 /COOLANT FANS ON
- 20 /TORCH CONTACTOR ON +
- 21 /PLASMA ENABLE RELAY
- 22 COMMON
- 23 PILOT CURRENT SIG -
- 24 NC
- 25 PILOT CURRENT SIG +
- 26 COMMON
- 27 WORK CURRENT SIG -
- 28 WORK CURRENT SIG +
- 29 NC
- 30 AMBIENT TEMP
- 31 COOLANT TEMP
- \* Used with 1 Torch Option

**RIBBON CABLE 16 ckt**  
**CCM (J37) - DISPLAY PCB (J17)**

- 1,3,5,7 24 VDC
- 2,4,6,8 COMMON
- 9,10 NC
- 11-16 SERIAL DATA

**RIBBON CABLE 10 ckt**  
**RELAY PCB (J3) - PILOT PCB (J42)**

- 1,2 24 VDC
- 3,4,7,10 COMMON
- 5 PILOT ENABLE +
- 6 PILOT ENABLE -
- 8 PILOT CURRENT SIG -
- 9 PILOT CURRENT SIG +

Art # H-0148

Rev	Revision	By	Date	Rev	Revision	By	Date
AA	INTRO PER ECN-09789	DAT	05/8/2024				



The information contained in this drawing is the sole property of ESAB WELDING CUTTING. Any reproduction in part or as a whole without the written permission of ESAB WELDING & CUTTING is prohibited.

Title: **SCHEMA TIC**  
**AC & PAK 300A\_380-415, 480VAC SYS**

420 National Business Parkway  
 5th Floor  
 Annapolis Junction, MD 20701

Date Printed: 5/28/2024 Date Revised: 5/28/2024

Drawn: DAT Date: 5/9/2024

Size: C Sheet: 1 of 2

Drawing Number: **42X1685**

# APPENDIX 14: SYSTEM SCHEMATIC NON CE PG 2

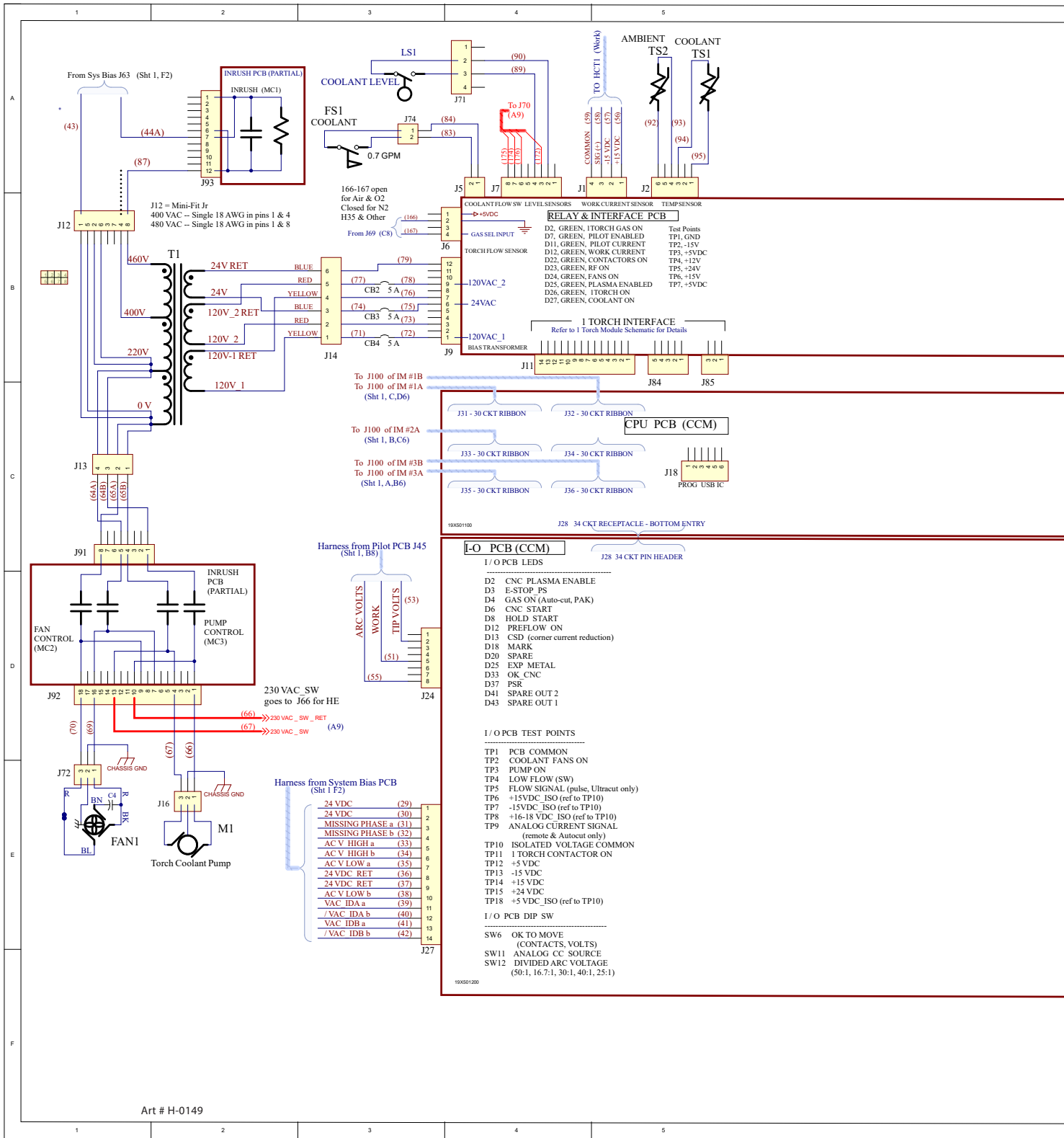

APPENDIX

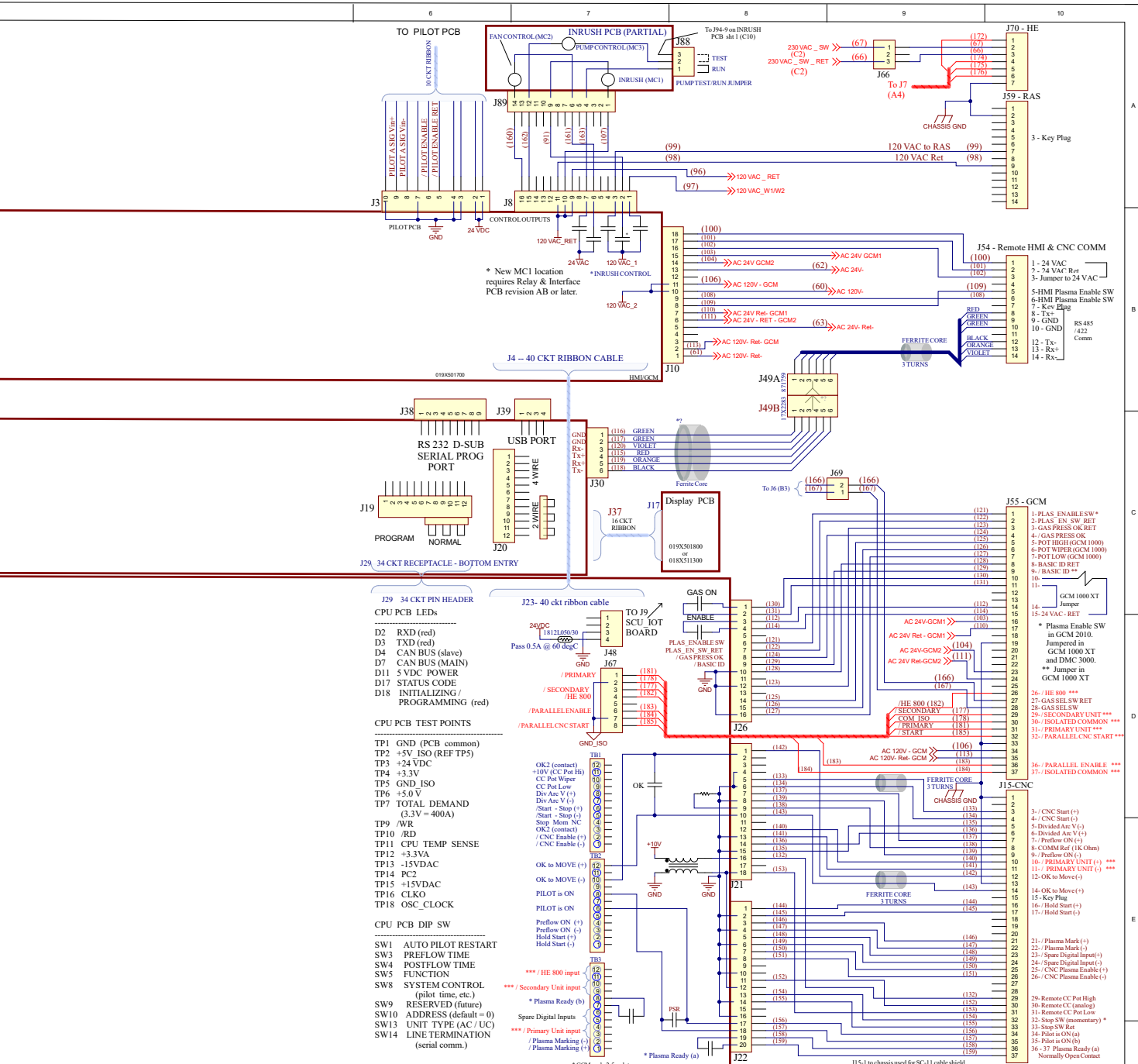

Rev	Revision	By	Date
AA	INTRO PER ECN-09789	DAT	05/9/2024

Rev	Revision	By	Date

Art # H-0149

420 National Business Parkway  
5th Floor  
Annapolis Junction, MD 20701

Date Printed: 5/28/2024 Date Revised: 5/28/2024  
Drawn: DAT Date: 5/9/2024  
Size: C Sheet: 2 of 2  
Drawing Number: 42X1685

The information contained in this drawing is the sole property of ESAB WELDING CUTTING. Any reproduction in part or as a whole without the written permission of ESAB WELDING & CUTTING is prohibited.

Title: SCHEMATIC  
AC & PAK 300i\_380-415, 480VAC SYS

APPENDIX

# APPENDIX 15: SYSTEM SCHEMATIC CE PG 1

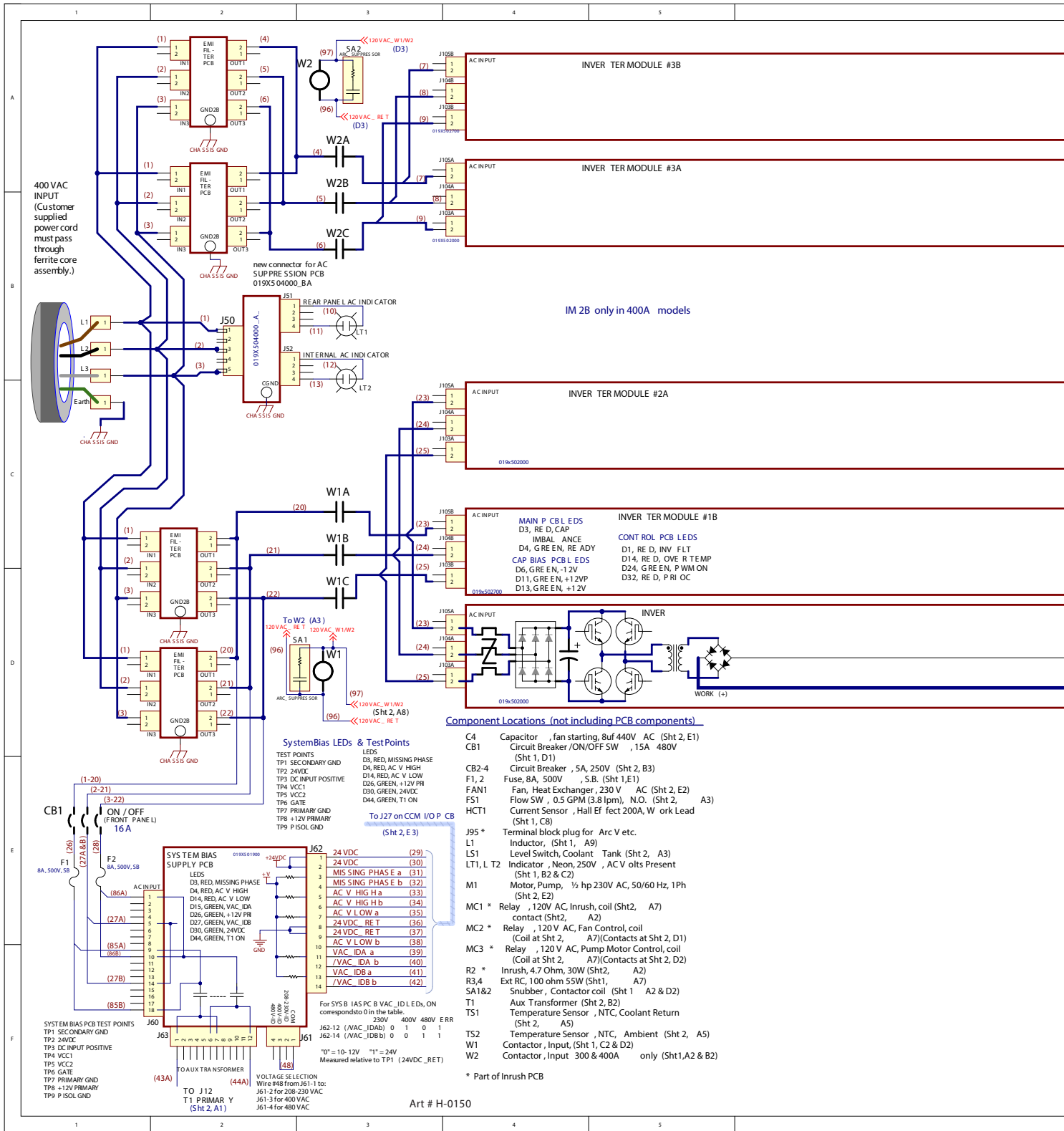

APPENDIX

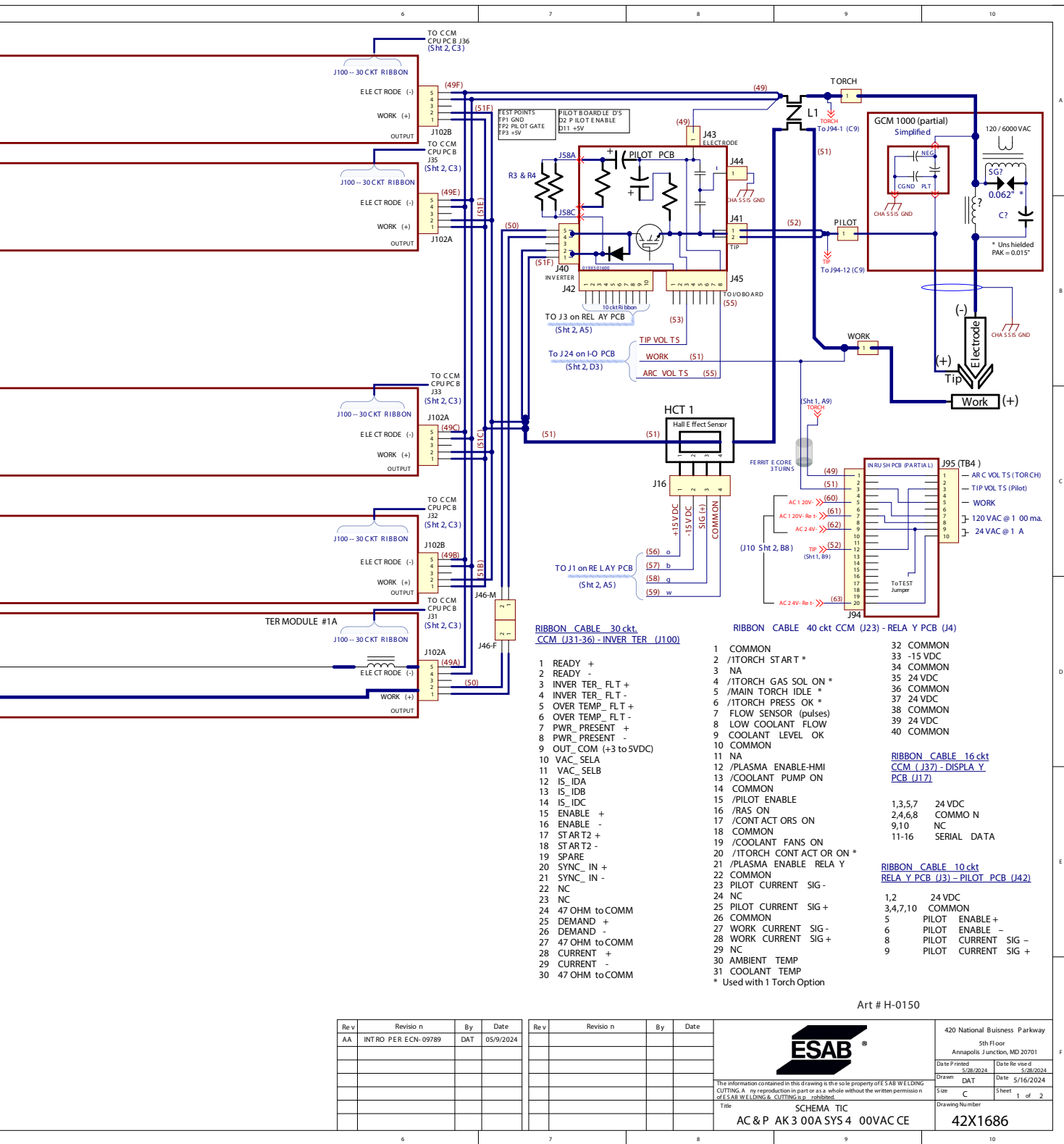

Rev	Revisio n	By	Date
AA	INTRO PER ECM-09789	DAT	05/9/2024

Rev	Revisio n	By	Date

**ESAB**

The information contained in this drawing is the sole property of ESAB WELDING CUTTING, A. ny reproduction in part or as a whole without the written permission of ESAB WELDING & CUTTING is strictly prohibited.

Title: SCHEMA TIC  
AC & P AK 3 00A SYS 4 00VAC CE

420 National Business Parkway  
5th Floor  
Annapolis Junction, MD 20701  
Date Printed: 5/28/2024  
Date Re used: 5/28/2024  
Drawn: DAT Date: 5/16/2024  
Size: C Sheet: 1 of 2  
Drawing Number: 42X1686

# APPENDIX 16: SYSTEM SCHEMATIC CE PG2

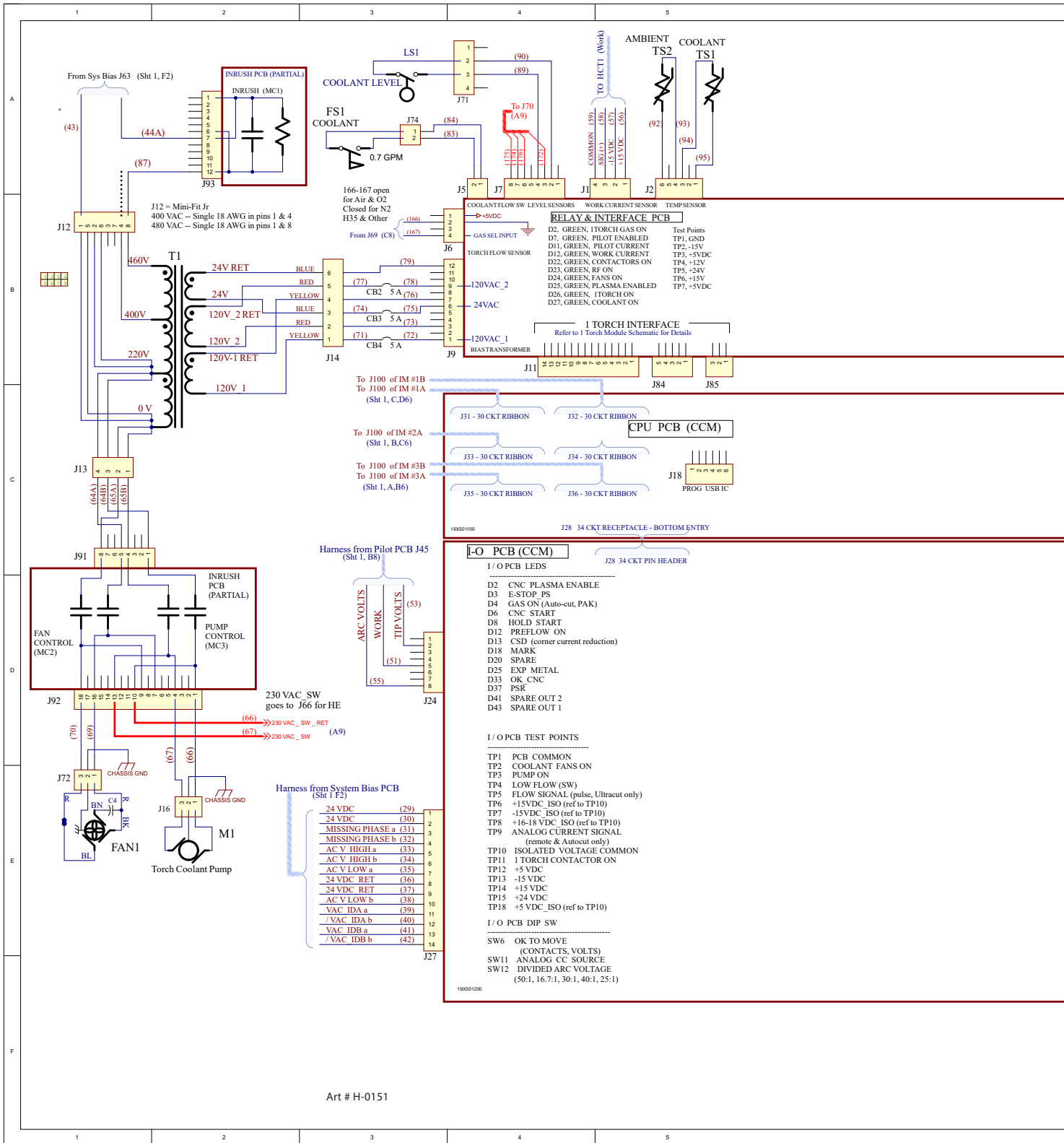

APPENDIX

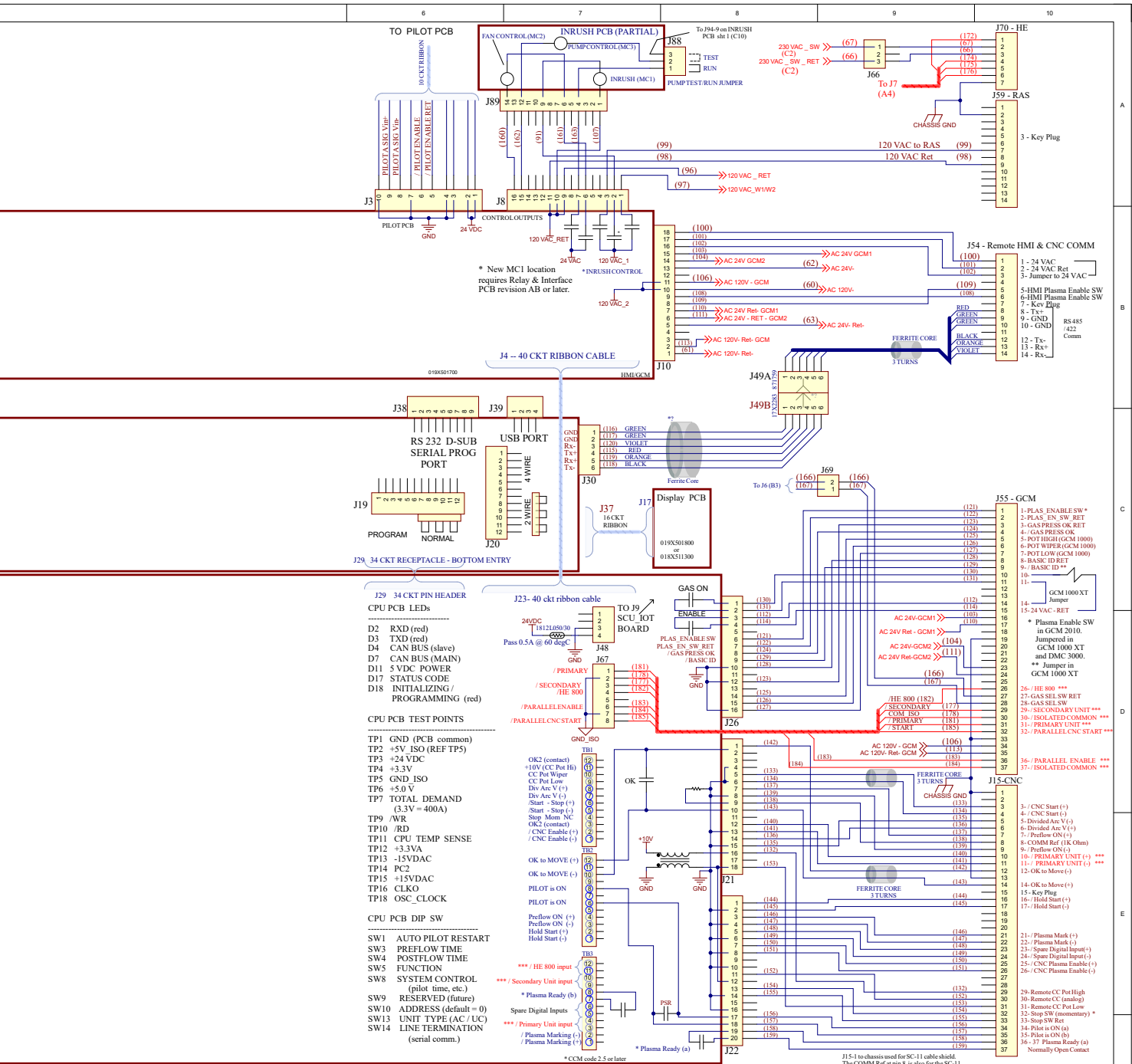

\* New MCI location requires Relay & Interface PCB revision AB or later.

\* Inrush Control

\* Plasma Ready (a)

\* Plasma Ready (b)

\*\*\* / Secondary Unit input

\*\*\* / Primary Unit input

\*\*\* / Plasma Marking (+)

\*\*\* / Plasma Marking (-)

\*\*\* / Plasma Marking (+)

\*\*\* / Plasma Marking (-)

\*\*\* / Plasma Marking (+)

\*\*\* / Plasma Marking (-)

\*\*\* / Plasma Marking (+)

\*\*\* / Plasma Marking (-)

\*\*\* / Plasma Marking (+)

\*\*\* / Plasma Marking (-)

\*\*\* / Plasma Marking (+)

\*\*\* / Plasma Marking (-)

\*\*\* / Plasma Marking (+)

\*\*\* / Plasma Marking (-)

\*\*\* / Plasma Marking (+)

\*\*\* / Plasma Marking (-)

\*\*\* / Plasma Marking (+)

\*\*\* / Plasma Marking (-)

\*\*\* / Plasma Marking (+)

\*\*\* / Plasma Marking (-)

\*\*\* / Plasma Marking (+)

\*\*\* / Plasma Marking (-)

\*\*\* / Plasma Marking (+)

\*\*\* / Plasma Marking (-)

\*\*\* / Plasma Marking (+)

\*\*\* / Plasma Marking (-)

\*\*\* / Plasma Marking (+)

\*\*\* / Plasma Marking (-)

\*\*\* / Plasma Marking (+)

\*\*\* / Plasma Marking (-)

\*\*\* / Plasma Marking (+)

\*\*\* / Plasma Marking (-)

\*\*\* / Plasma Marking (+)

\*\*\* / Plasma Marking (-)

\*\*\* / Plasma Marking (+)

\*\*\* / Plasma Marking (-)

\*\*\* / Plasma Marking (+)

\*\*\* / Plasma Marking (-)

\*\*\* / Plasma Marking (+)

\*\*\* / Plasma Marking (-)

\*\*\* / Plasma Marking (+)

\*\*\* / Plasma Marking (-)

\* CCM code 2.5 or later

J15-1 to chassis used for SC-11 cable shield.

The COMM Ref at pin 8 is also for the SC-11.

J15-13 connects SC-11 chassis to FC chassis.

\* Used with Momentary CNC Start SW

\*\*\* Rev AD and later

Rev AA INTRO PER ECN-09789 DAT 05/9/2024

Rev AA INTRO PER ECN-09789 DAT 05/9/2024

Rev AA INTRO PER ECN-09789 DAT 05/9/2024

Rev AA INTRO PER ECN-09789 DAT 05/9/2024

Rev AA INTRO PER ECN-09789 DAT 05/9/2024

Rev AA INTRO PER ECN-09789 DAT 05/9/2024

Rev AA INTRO PER ECN-09789 DAT 05/9/2024

Rev AA INTRO PER ECN-09789 DAT 05/9/2024

Rev AA INTRO PER ECN-09789 DAT 05/9/2024

Rev AA INTRO PER ECN-09789 DAT 05/9/2024

Rev AA INTRO PER ECN-09789 DAT 05/9/2024

Rev AA INTRO PER ECN-09789 DAT 05/9/2024

Rev AA INTRO PER ECN-09789 DAT 05/9/2024

Rev AA INTRO PER ECN-09789 DAT 05/9/2024

Rev AA INTRO PER ECN-09789 DAT 05/9/2024

Rev AA INTRO PER ECN-09789 DAT 05/9/2024

Rev AA INTRO PER ECN-09789 DAT 05/9/2024

Rev AA INTRO PER ECN-09789 DAT 05/9/2024

Rev AA INTRO PER ECN-09789 DAT 05/9/2024

Rev AA INTRO PER ECN-09789 DAT 05/9/2024

Rev AA INTRO PER ECN-09789 DAT 05/9/2024

Rev AA INTRO PER ECN-09789 DAT 05/9/2024

Rev AA INTRO PER ECN-09789 DAT 05/9/2024

Rev AA INTRO PER ECN-09789 DAT 05/9/2024

Rev AA INTRO PER ECN-09789 DAT 05/9/2024

Rev AA INTRO PER ECN-09789 DAT 05/9/2024

Rev AA INTRO PER ECN-09789 DAT 05/9/2024

Rev AA INTRO PER ECN-09789 DAT 05/9/2024

Rev AA INTRO PER ECN-09789 DAT 05/9/2024

Rev AA INTRO PER ECN-09789 DAT 05/9/2024

Rev AA INTRO PER ECN-09789 DAT 05/9/2024

Rev AA INTRO PER ECN-09789 DAT 05/9/2024

Rev AA INTRO PER ECN-09789 DAT 05/9/2024

Rev AA INTRO PER ECN-09789 DAT 05/9/2024

Rev AA INTRO PER ECN-09789 DAT 05/9/2024

Rev AA INTRO PER ECN-09789 DAT 05/9/2024

Rev AA INTRO PER ECN-09789 DAT 05/9/2024

Rev AA INTRO PER ECN-09789 DAT 05/9/2024

Rev AA INTRO PER ECN-09789 DAT 05/9/2024

Rev AA INTRO PER ECN-09789 DAT 05/9/2024

Rev AA INTRO PER ECN-09789 DAT 05/9/2024

Rev AA INTRO PER ECN-09789 DAT 05/9/2024

Rev AA INTRO PER ECN-09789 DAT 05/9/2024

Rev AA INTRO PER ECN-09789 DAT 05/9/2024

Rev AA INTRO PER ECN-09789 DAT 05/9/2024

Rev AA INTRO PER ECN-09789 DAT 05/9/2024

Rev AA INTRO PER ECN-09789 DAT 05/9/2024

Rev AA INTRO PER ECN-09789 DAT 05/9/2024

**ESAB**

420 National Business Parkway  
5th Floor  
Annapolis Junction, MD 20701

Date Printed: 5/29/2024 Date Revised: 5/29/2024  
Drawn: DAT Date: 5/9/2024  
Size: C Sheet: 2 of 2

Drawing Number: 42X1686

The information contained in this drawing is the sole property of ESAB WELDING CUTTING. Any reproduction in part or as a whole without the written permission of ESAB WELDING & CUTTING is prohibited.

Title: SCHEMATIC AC & PAK 300A\_SYS 400VAC CE

# APPENDIX 17: INVERTER SCHEMATIC

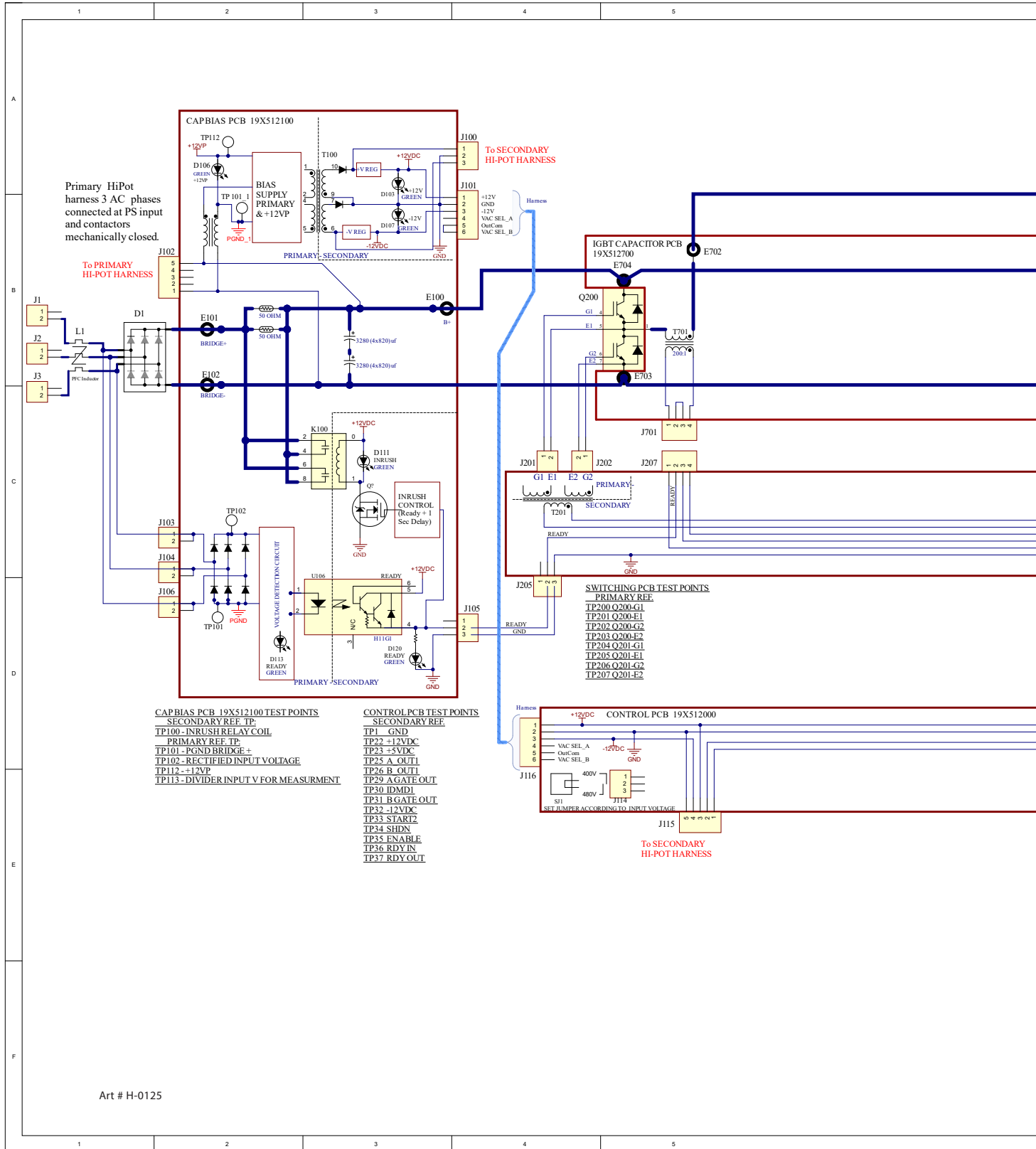

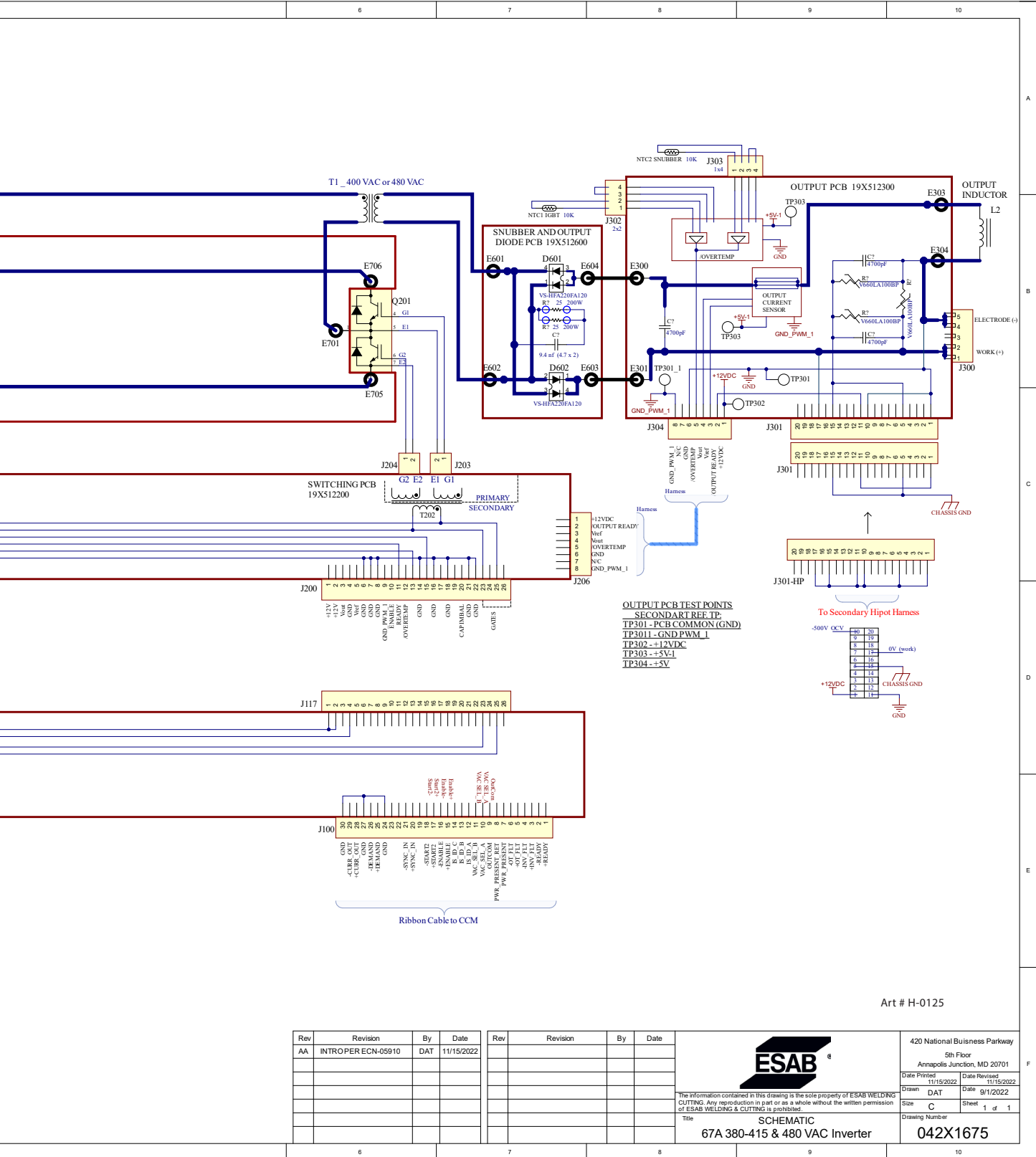

Art # H-0125

Rev	Revision	By	Date
AA	INTROPER ECN-05910	DAT	11/15/2022

Rev	Revision	By	Date

**ESAB**

The information contained in this drawing is the sole property of ESAB WELDING CUTTING. Any reproduction in part or as a whole without the written permission of ESAB WELDING & CUTTING is prohibited.

Title: **SCHEMATIC**  
 67A 380-415 & 480 VAC Inverter

420 National Business Parkway  
 5th Floor  
 Annapolis Junction, MD 20701

Date Printed: 11/15/2022  
 Date Revised: 11/15/2022

Drawn: DAT  
 Date: 9/1/2022

Size: C  
 Sheet: 1 of 1

Drawing Number: **042X1675**

# APPENDIX 18: GAS CONTROL & ARC STARTER

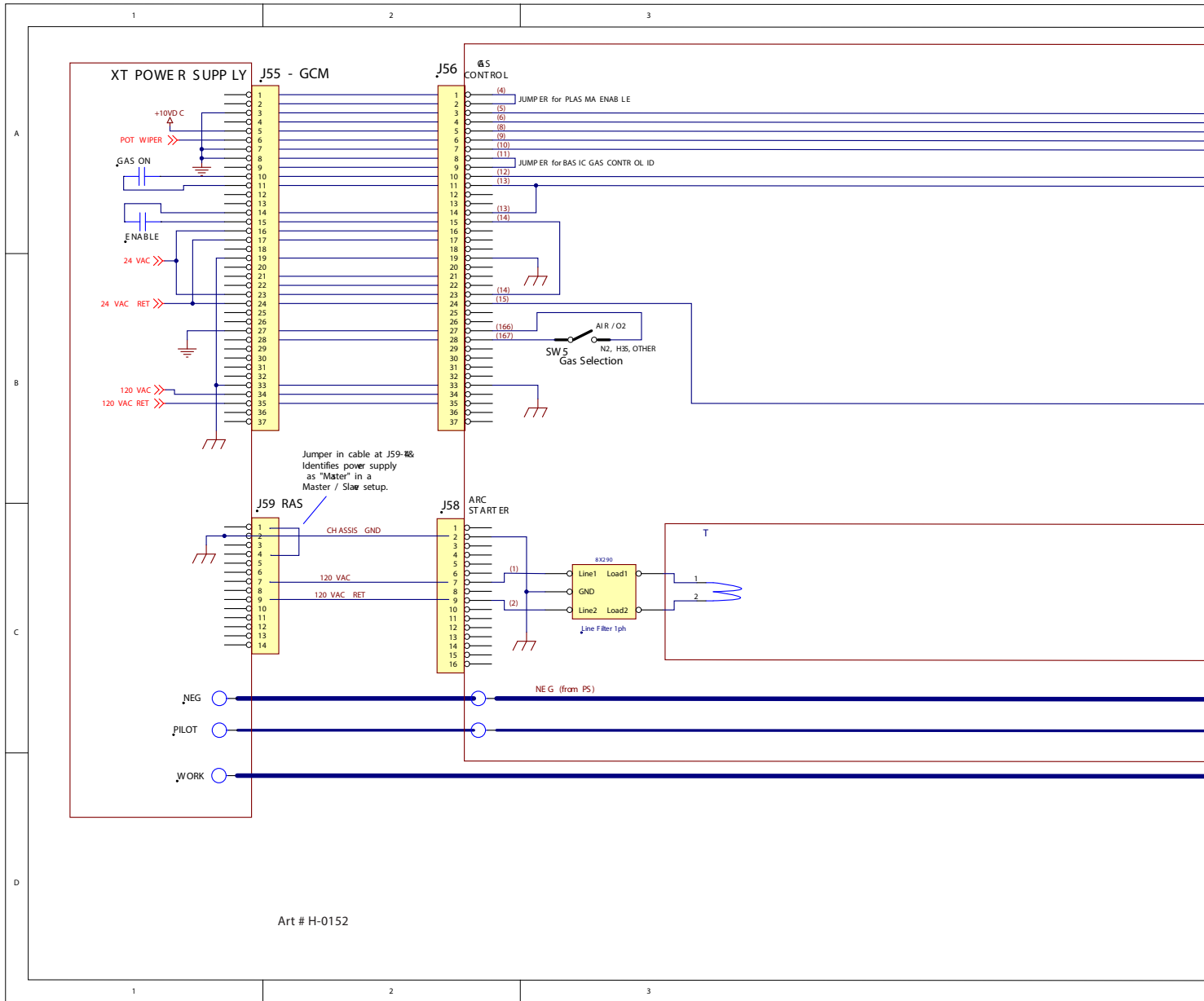

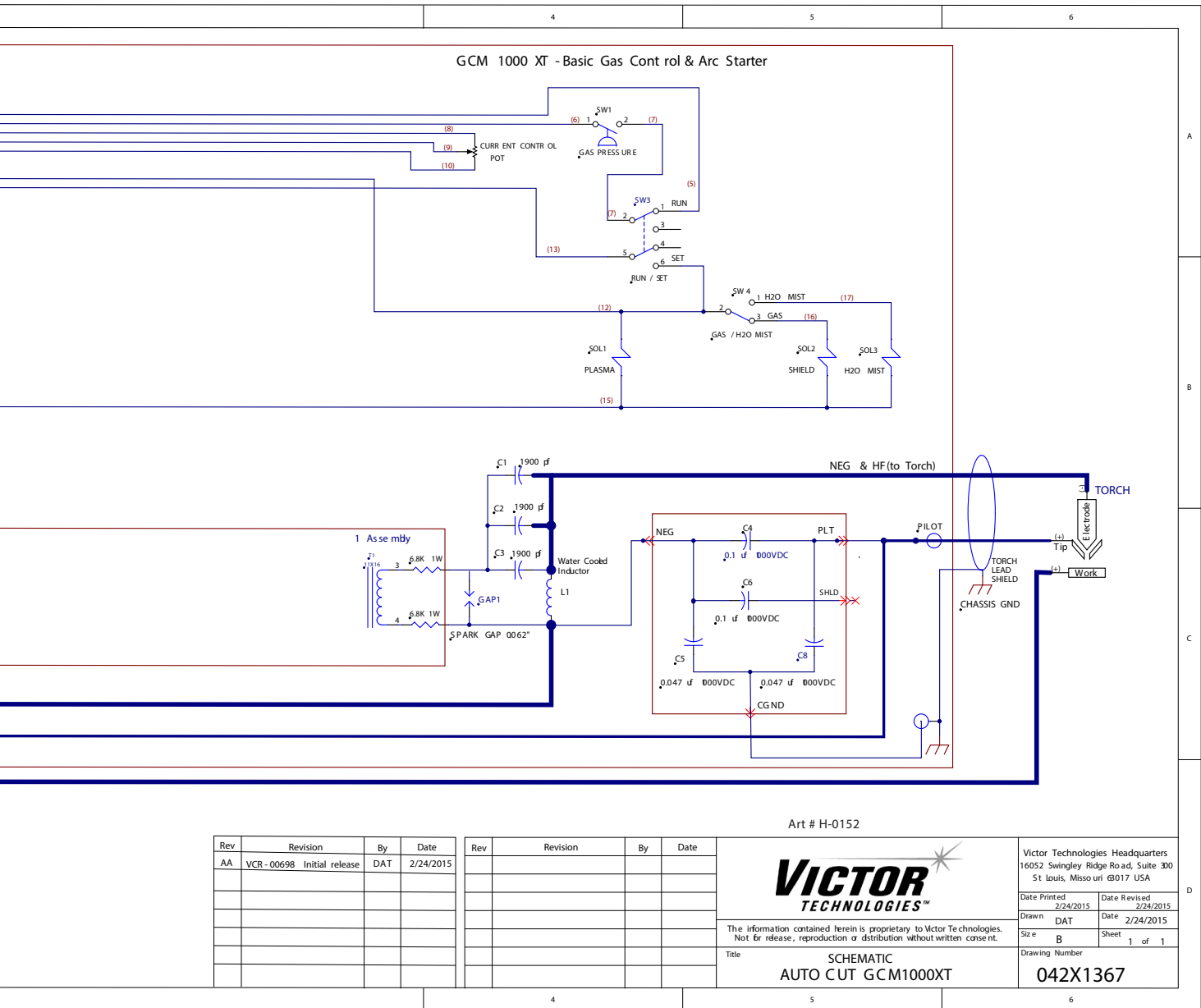

# APPENDIX 19: ADVANCED TROUBLESHOOTING

## System Overview

The Auto-Cut 200 XT & 300XT also Pak 200i and Pak 300i as well as the UC131, 201, 301, and 401 include from two to six 67A inverter modules (IM). Previous models had inverter modules with one or two 67A inverter sections. Now we have separated each section into its own inverter. In keeping with the designations of previous models we still call these, from bottom to top, IM 1A; IM 1B; IM 2A; IM 2B; IM3A; IM3B.

Each inverter section can supply up to 67A but does not do so in all configurations:

A 400A unit uses 6 inverters.  $400A / 6 = 66.67A$  per inverter.

A 300A unit uses 5 inverters.  $300A / 5 = 60A$  per inverter.

A 200A unit uses 3 inverters.  $200/3 = 66.67A$  per inverter.

A 100A unit uses 2 inverters.  $100/2=50A$  per inverter.

### Unit configurations.

Except for the AC 200 XT all other units have the same chassis with room for up to 6 IMs. The unused sections have blank panels to filling the empty locations required for proper air flow needed for cooling.

### Inverter module cooling.

The power semiconductors of the inverter modules are liquid cooled allowing us to get more power in a smaller area and at lower cost. Each IM has a liquid cooled heatsink or "cold plate". The magnetic components, transformers and inductors, are air cooled and mounted on the back side of the IMs where they are exposed to high volumes of air flow from the cooling fans whose air also cools liquid coolant in the radiator or heat exchanger. It is important that lower right side panel be in place or the air flow will not be proper for cooling the magnetics.

### Inverter control.

The inverter are operated as separate inverters whose outputs are connected in parallel. They are controlled independently from the Command and Control Module (CCM) which is the "brains" of the system. Each has a separate ribbon cable connected to it coming from the CCM which has 6 connectors, J31 – J36 corresponding to the inverter 1A through 3B. The ribbon cables are labeled on the inverter ends as INV with the number (INV 1A, INV 1B, etc.). A 100A unit will only have ribbon cables in J31 & J32; a 200A will have J31-J33 filled with the others empty. 300A will have J34 missing with the others filled.

Other boards in the system include the **System Bias Supply, Inrush PCB, Relay & Interface PCB, Display PCB, Pilot PCB and AC Suppression PCB**. The CCM has 2 boards, the I/O (input/output) and the CPU (central processing unit) board. The CE units will also have one or more EMI Filter boards on the input power.

**System Bias supply PCB** is powered from the 3 phase AC input and works from about 150V to over 600V covering all the normal voltage ranges. It can operate from 2 phases (single phase) so it still provides bias power and can report a fault if a phase is missing.

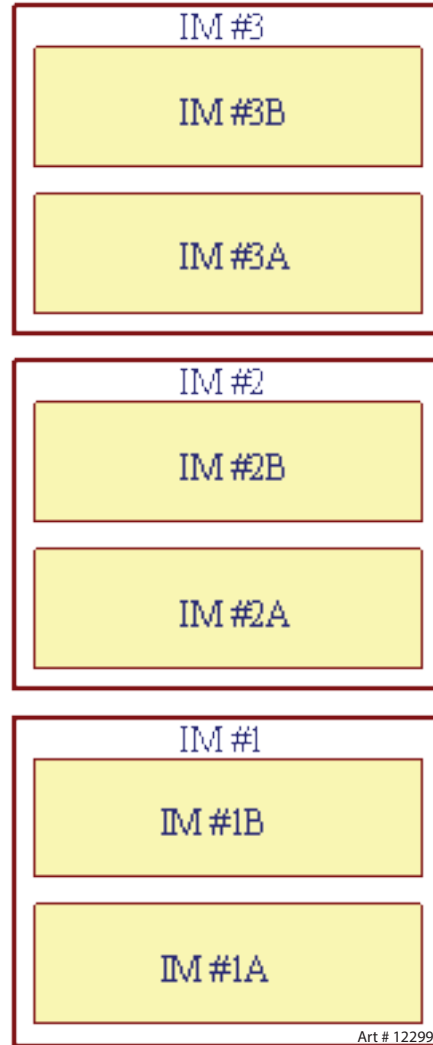

J31	--To INV 1A
J32	--To INV 1B
J33	--To INV 2A
J34	--To INV 2B
J35	--To INV 3A
J36	--To INV 3B

Art # 12300

The supply's output is 24 VDC which powers the Relay board, the Display, the Pilot board and the 2 boards in the CCM. System Bias also contains circuits to detect missing phase and determine if the AC voltage is within the correct range, not too high or too low. It also signals to the CCM what voltage the unit is configured for. The System Bias supply PCB includes a relay, K1, which only applies voltage to Auxiliary transformer, T1, primary when the input voltage is in the correct range.

**Inrush PCB** has relays MC1 (Inrush); MC2 (Fan Control) & MC3 (Pump Control) as well as the inrush limiting resistor were previously mounted on the horizontal chassis in earlier models. These are moved to the Inrush PCB. A test/run jumper J88 has been added for testing and purging the pump during service or initial setup.

The **Relay and Interface PCB** Accepts and distributed the output of the Aux Transformer. It has relay to control the pump, fans, input contactors, the Arc Starter and the Inrush relays. A circuit on the Relay board accepts input from the Work current sensor, HCT1, and Pilot current sensor (on the Pilot PCB) and sends the Enable signal to the Pilot boards IGBT switches via the J3 to J42 ribbon cable. Other inputs on the Relay board include those from the Negative Temperature Coefficient (NTC) ambient and coolant temperature sensors. Coolant tank level switch and coolant flow switch, which determines if the flow is above the required minimum rate, also send signals to the Relay Board. Ultra-Cut units include a flow sensor whose output to the Relay Board is a series of pulses whose frequency indicates the flow rate and can detect the presence of gas bubbles in the coolant. All these signals pass to the CCM via a 40 conductor ribbon cable going to the CCM I/O board.

The **Display Board** Has LEDs for AC, TEMP, GAS & DC. It also has a 4 digit 7 segment display for status and fault information. AC LED indicates the input contactors to the inverters have been commanded to close, but does not mean they are closed. TEMP means one or more inverters or the coolant has exceeded the allowed temperature. GAS means gas is flowing and coolant flow is OK. DC means the inverters output voltage is above 60 VDC.

The first digit of the 7 segment display shows the letter, "C"; "E"; "L" or is blank. During the initial power up sequence the letter "C" followed by the other 3 digits, indicates the CCM code revision. Status or Fault codes which may occur during the power up sequence or any time thereafter are preceded by letters "E" for an active fault or "L" for a "latched" or "last" fault that stopped the process but is no longer active. When there is no Fault or active Status code, the output current setting is displayed with the first digit blank. If the system is an Ultra-Cut XT using the Auto Gas Control, DFC 3000, the display will show "0" until a process has been loaded. If there is a fault or other status showing the display will alternate between the current setting and the fault.

The **Pilot PCB** contains a pair of parallel IGBT transistors working as an electronic switch to connect and disconnect the torch tip from the 1st inverter section.

When the pilot electronic switch is closed and the pilot is ignited by the Arc Starter, current from the 1st section flows between electrode and tip. Then as transfer begins, a small current from the 2nd inverter flows from electrode to work. When transfer is detected the pilot switch is opened and current from the 1st section is free to flow to the work through the diode which is also on the Pilot board. The Pilot PCB also contains a pilot current sensor to detect and measure the level of pilot current. Additional resistor/capacitor (RC) circuits on the pilot PCB assist and stabilize the pilot and transferred arcs.

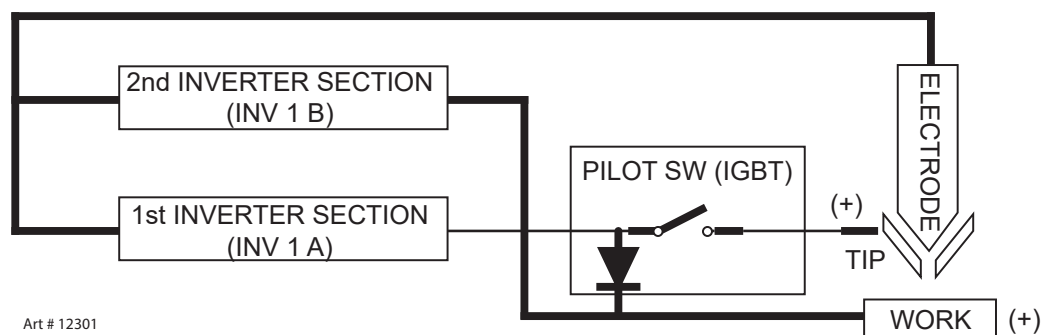

The **AC Suppression PCB** has capacitors and other transient suppression components to protect the system from transients on the AC lines. It also provides power for the neon AC present indicators which illuminate when AC power is connected even with ON-OFF switch, CB1, off.

## Differences between various models.

Auto-Cut 200 or 300 XT units use the basic gas control/arc start circuits consisting of single gas inlets, one for Plasma, one for Gas Shield and one for water inlet, optional for AC 200 XT, for H2O Mist shield. There is a pressure regulator and gauge for each gas inlet and water flow meter/control when the H2O Mist option is used. All 3 are turned on/off with control solenoids. Changing gas types requires connecting different gasses to the rear panel and setting the gas switch on the rear panel to match the plasma gas type. There is no separate pilot (Prewflow) gas at this time.

The Auto-Cut and PAK XT units use the basic gas control / Arc starter is the conventional spark gap type with water cooled coil that we've used for several years. This arc starter injects the HF onto the torch electrode via the negative lead with the return via the tip and pilot lead. The Ultra-Cut XT units use the remote arc starter, RAS 1000 XT. In place of the spark gap the RAS 1000 XT uses a solid state ignition module to create the HF pulses which are injected onto the tip and return via the electrode, the opposite direction of that used in the Auto-Cut, Auto-Cut XT and the older RAS 1000 used with the Ultra-Cut units.

The **AC 200 XT** and **PAK 200i** has the gas control and arc starter built into the main enclosure in the area that is used for the top inverter module in other units of this family. It is called a **GCM 1000 XT**. Both Auto-Cut XT models and the **PAK 300 XT** have an analog current control (Potentiometer). On the front panel of the main unit for the AC 200 XT and the and in the upper box, the GCM 1000 XT, for the AC 300 XT and PAK 300i version. In either case the amperage setting is displayed on the front panel digital display.

Both Auto-Cut models have the gas mode switch on the rear, for the AC 300 XT next to the gas inlets of the GCM XT. On the AC 200 XT it's near the connectors, fuses & circuit breakers. The switch should be set according to the type of gas, AIR/O2 or N2, H35 or other non-oxidizing gas, being used for the plasma.

In the AC 200 XT the Pilot board is mounted on the upper section of the second inverter module (IM#2) the ½ module, in the place of the second or "B" section if it was a full module. The AC 300 XT and all Ultra-Cut XT models have the Pilot board on the opposite side from the inverters, the "circuit breaker" side, in the upper rear behind the CCM module. Refer to the Replacement Parts section of the manual for illustrations showing the locations.

Ultra-Cut XT units, 100, 200, 300 & 400A units all can use either the **GCM 2010** "manual" Gas control or the **DFC 3000 Auto Gas Control**. These gas controls remain unchanged from earlier Ultra-Cut units.

Ultra-Cut XT units use the same flow switch, FS1, as the Auto-Cut XT and PAK units to detect and prevent operation when coolant flow is below the minimum of 0.75 GPM (2.8 l/m).

Ultra-Cut XTs have standard consumables for cutting currents lower than those used for Auto-Cut XT, PAK 300i, 15A vs. 55A as well as marking at lower currents. To improve operation at these lower currents an additional output inductor, L1, is added in series with the 1st inverter (IM#1A).

## Status codes.

The codes for the power supply are displayed on the Display PCB 4 digit numerical display. Some codes refer to the Gas Controls but more detailed Gas Control codes will be found on the individual gas controls. The gas controls used with the XT family of plasma supplies have not changed. They have their own set of status codes which should be covered in another section. This guide assumes you have first considered the Status Code Tables in the Operation Section of the unit manual. Individual codes will point to different inverter sections while this guide groups similar codes together. For example code E (or L) 249 indicates an inverter fault in Inverter 2A. This guide covers codes 247-252 in one section as they are all the same, varying only by which inverter and section they refer to.

The codes are separated into 6 groups.

Group 1	Plasma Process -- Relating to pilot, transfer, torch voltages, etc.
Group 2	Plasma Power Supply -- Primarily the Inverter Sections
Group 3	Interface to Gas controls -- Mainly the DFC 3000
Group 4	Cooling System -- The liquid cooling system for the torch and inverters
Group 5	CCM -- Communications port to the gas controls
Group 6	CCM & Program update faults plus flow SW

For the XT units we are using a 3 digit code with group 1 codes in the 100's, group 2 in the 200s etc. These correspond to the older codes used in previous units, where 1-1 is now 101. For the most part the codes have the same meaning. Where an older code no longer applies to the XT system we don't use it over again and have left it reserved to avoid confusion. For example the code 204 (2-4) which meant the inverter module wasn't ready. We now detect that error in a different way that has a somewhat different meaning so we have reserved the 204 Code.

While most of the codes indicate a fault has occurred, a few of them, such as 304 (formerly 3-4), simply refer to the current status. 304 indicates either "priming" where the pump is filling the system with coolant or more often "purging" where the gas is flowing to dry the consumables after replacing them or purging the gas lines when a different gas type has been selected.

### Troubleshooting (General)

In many cases where the cause may be listed as a cable or wire disconnected but also includes loose or broken.

All Ribbon cables have an extra receptacle near one end for measuring signals on the cable.

A number of the measurements will require probing of some small connectors or measuring signal on ribbon cables. For probing the small connectors, standard meter probes are usually too big. We suggest making a couple probes using steel wire. Copper buss wire isn't stiff enough. A paper clip is a little too big. One idea is take a socket from an Amp mate-n-loc or similar connector into which your meter probe will fit and crimp a small piece of steel wire, (0.020 to 0.025" dia.; (0.5-0.6 mm) works best), into where wire would normally be crimped. The wire should be soldered and crimped. The steel wire may be found in hobby stores that cater to model building.



Insulate all but the end of the wire and slide these onto your meter probe. If your meter has alligator clip adaptors you could hold the wire in these as well, be sure they don't short together.

### Problems that do not set Status or Fault codes:

1. At power on GAS LED blinks continuously, no code set. Real problem is no or low coolant flow but it takes 4 minutes before code is set and people don't wait that long.

## Power Supply Status Codes

### Group 1, Process Codes

#### 101 Plasma Enable Is Disabled

Code 101 is activated by either an open circuit between TB1-1 & 2 on CCM I/O PCB or Plasma Enable switched off on the GCM 2010 or on the TSC 3000. TB1-1 & 2 comes from the factory with a jumper installed. An installer may remove the jumper and connect a separate Plasma Enable switch or use the Plasma Enable wires included in the 37 pin CNC cable used with the Ultra-Cut XT & Auto-Cut 300XT and PAK 300i. The Auto-Cut 200XT which uses a 14 pin CNC does not have the Plasma Enable in the cable. These may be used to connect to the cutting table E-Stop switch. In either case the jumper would be removed from TB1-1 & 2. 101 is not a latched code, it clears as soon as the condition is fixed.

External plasma enable is not generally used with a hand torch (PAK unit) but can be wired to TB1 same as for AC 300XT.

Causes for 101 code other than one of the Enable switches being off (see detailed descriptions below):

- Gas Control Cable from J55 to gas control not connected.
- Ribbon cable from Relay board to I/O board not connected.
- CNC cable not connected (if using a Plasma Enable switch or output from the cutting table or robot).
- Defective Relay PCB
- Defective CCM I/O PCB

Special case: Display alternates between E101 and ----. This happens when there is both a missing phase and Plasma enable is off. It is probably a bug in the code, it should be showing E101 & E201 (missing phase code). We will likely fix this in a later code release but be aware of it for now.

## External or CNC Plasma Enable D2, CNC PLASMA ENABLE LED, is not on.

- LED D2 on the CCM will be on if this input is satisfied either with the jumper on TB1- 1 & 2 or an external or CNC switch. If the jumper is in place and the LED is not on, the CCM is most likely defective.
- If the jumper at CCM TB1-1 & 2 has been removed to use an external switch, install a jumper as a test. If D2 illuminates the problem is with the switch or it's wiring.
- If Plasma Enable is wired through the CNC cable remove the cable and jumper J15 pins 25 & 26. If D2 still not on there may be a problem in the wiring inside the power supply.

## Plasma Enable from Gas Control or TSC 3000

If the External or CNC Plasma Enable is satisfied, D2 is on, a relay K7 on the CCM I/O PCB energizes supplying +15V to another relay K1 on the I/O board. An active low signal, /Plasma Enable-HMI, comes from TSC 3000 Plasma Enable switch via the Relay PCB or if TSC 3000 is not installed the signal originates on the Relay PCB. This signal applies ground to the K1 relay energizing it and lighting the LED, D3 on the I/O board. K1's contacts go back to the Relay board and the Gas control connector J55 to allow turning on relays and solenoids on those devices. The AC 200 XT does not use the separate Gas Control or the TSC 3000.

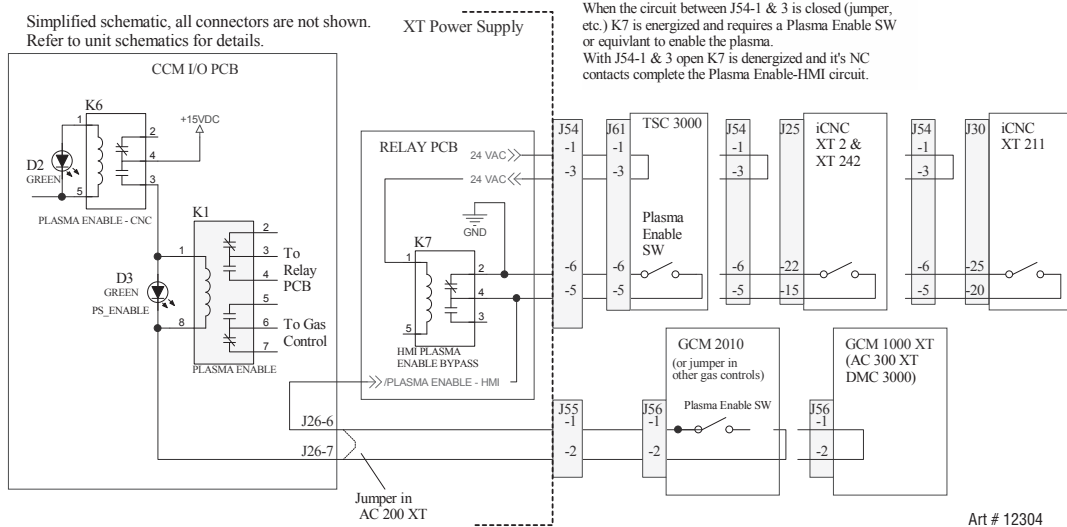

If a TSC 3000 is not connected or unit is an Auto-Cut, K7 on the Relay PCB is de-energized and GND is connected through its normally closed contacts. If the TSC is connected, 24 VAC through a jumper in the TSC 3000 energizes K7, opening its NC contacts and now GND connects through the TDC 3000 Plasma Enable switch. The GND obtained by either path passes through the GCM 2010 Plasma Enable switch or through a jumper (J56-1 to J56-2) present in the other gas controls (GCM 1000 XT or DMC 3000) and is connected to the coil of K1 on the I/O PCB. If the CNC Plasma Enable is also active (D2 is on) +15V will be connected to K1's coil through the relay K7 on the I/O PCB. This energizes K1 and turns on D3, Plasma Enable LED. The contacts of K1 go back to the Relay board and to the Gas control to enable power to connect to relays and solenoids in those items.

### Troubleshooting:

1. If both D2 and D3 are on and you still have 101 fault replace the CCM. Otherwise go to step 2 except if it's an AC 200 XT skip to step 4.
2. If D3 is not on and there is a TSC 3000 in use remove its cable from J54. K7 on the Relay board will de-energize and satisfy the Plasma Enable to K1. If D3 is now on problem was in the TSC 3000 or its cable. Otherwise reconnect the cable.
3. For an Ultra-Cut with DFC 3000 or GCM 2010 or an Auto-Cut 300 with a GCM 1000 XT remove the cable from J55 the gas control connector and jumper pins 1 & 2. If D3 is on now problem is in the Gas Control or its cable. If D3 still not on replace the Gas Control cable.
4. If neither of the above steps works, on the CCM I/O board, jumper J26-7 to GND (TP1 on I/O). If D2 is on and D3 still does not light then replace the CCM.

5. If D3 does light in the above step find the 40 pin ribbon cable plugged in to the top of the CCM. Confirm that it is plugged in to both the CCM and the Relay board and the connector tabs are locked in place. Now using the spare receptacle measure voltage between GND (TP1 on I/O) and the ribbon cable pin 12. It should be zero V. If not, if it's something like 10-15VDC, the ribbon cable is open or the Relay board is defective.

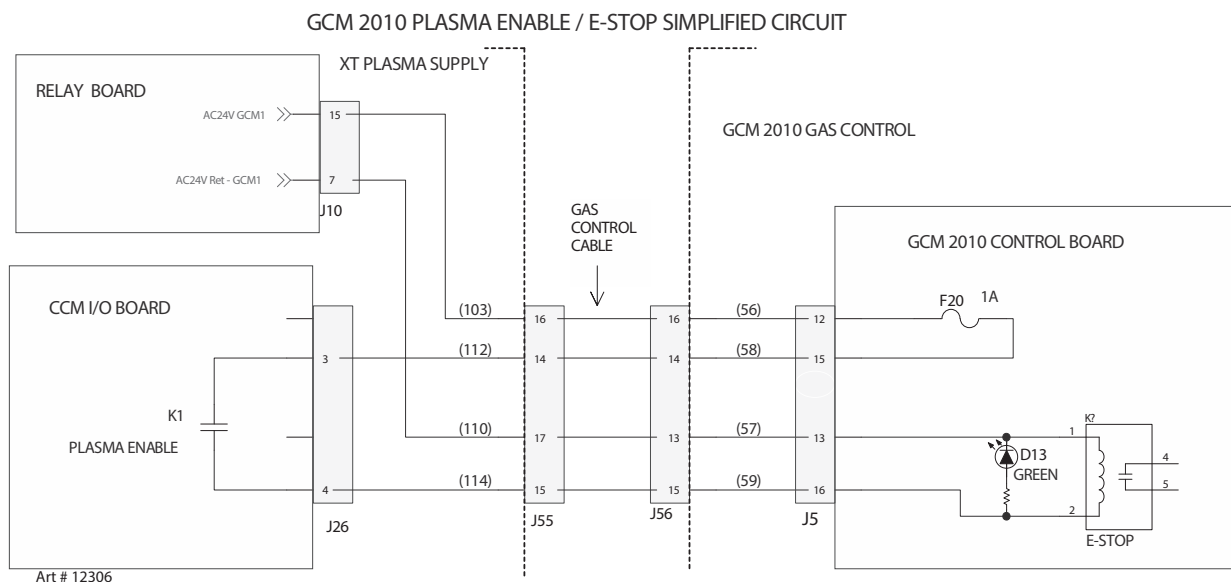

## 102 Pilot Ignition Failure

Code 102 is activated when there is no pilot current after 15 seconds of firing the Arc Starter. Pilot ignition requires the Pilot board to be enabled, pilot switch (IGBT) turned on and high voltage pulses (HF) from the arc Starter (either the Remote Arc Starter RAS 1000 XT or GCM 1000 XT or the arc starter built in to the AC 200 XT) applied between the tip and the electrode of the torch.

Possible Causes for 102 code:

- No HF to the torch due to broken pilot wire connection in the torch leads.
- No HF to the torch due to defective Arc Starter.
- Arc Starter not receiving power.
- Pilot board not enabled.
- Pilot board defective.
- Relay board defective.
- Work lead current sensor defective.
- CCM defective.

Troubleshooting:

1. Determine if the problem is a lack of HF (Arc Starter) or if it's due to the pilot circuit.

Auto-cut XT Arc Starter (inside main chassis for AC200 XT; in the GCM1000XT for AC300XT) and PAK 300i has open spark gap. If the spark gap is firing it is receiving power. A few early Ultra-Cut XT units were shipped with the RAS1000 Arc Starter. Troubleshoot them the same as the GCM1000XT below. Most Ultra-Cut XT units now use the RAS1000XT Arc Starter which doesn't use a spark gap and is covered in the next section.

### Arc starter with Spark Gap (Auto-Cut)

#### No spark at spark gap

1. Check that spark gap is set for 0.062" +/- 0.002". If gap is too high there may not be enough voltage from T1 to fire the gap.

2. Check for power to the high frequency (HF) transformer (T2 in AC 200 XT; and PAK 300i T1 in GCM1000XT) during the 15 seconds following preflow (ignition phase). Arc starter power comes through the rear panel circuit breaker CB4, make sure it isn't tripped.
  - a. For the GCM1000XT (AC300XT) and PAK 300i 120 VAC from J59-7 & 9 on the power supply rear panel connects to J58-7 & 9 on the GCM 1000XT. See diagram below. From J58 on the GCM1000XT it goes directly to the line filter and passes through the filter to primary of T1. During the ignition phase, check for 120 VAC on the T1 side of the line filter.
  - b. For AC200XT the HF transformer T2 has insulated Faston (also known as push on , stab-on, spade, etc.) on its primary wires. Disconnect these and measure for 120 VAC on the harness side during ignition phase.
3. If 120 VAC not present go to step 4.
  - a. If 120 VAC is present and still no spark, T1 (T2 in AC200XT) may be bad. Remove power and measure resistance of T1 (T2 in AC200XT) and PAK 300i primary and secondary. The primary should measure about 3-7 ohms. The secondary about 25-35 K ohms. If either measurement not correct replace T1 (T2 in AC200XT).
  - b. If T1 (T2 in AC200XT) measures OK, check for shorted capacitors C1-C3 (very unlikely).
4. No 120 VAC to T1 (T2 in AC200XT) and PAK 300i primary during the ignition phase (15 seconds following Preflow) check for 120 VAC into the line filter (GCM1000XT only). If it's there replace the filter. If 120 VAC isn't present at the line filter or if this is an AC 200XT go to step 5 in section Either Arc Starter below.

### Arc starter without Spark Gap (Ultra-Cut)

1. Check for power to the RAS 1000XT's Ignition Module during the 15 seconds following preflow (ignition phase). Arc starter power comes through the rear panel circuit breaker CB4, make sure it isn't tripped.
  - a. During the ignition phase, measure for 120 VAC at the input terminals marked 120 VAC on the Ignition module, a gray rectangular box with screw terminals on one side.



#### WARNING

Do not let the meter probes (or your hands) come in contact with the other terminals marked Hb and Ho or the other end of the wires connected to them. These can have 10,000 volt pulses which can cause physical harm and will damage your meter.

2. If 120 VAC is not present go to step 3.
  - a. If 120 VAC is present and still no spark, the Ignition Module may be bad.
3. 120 VAC to the remote Arc Starter comes from J59-7 & 9 on the power supply rear panel and connects to J58-7 & 9 on the RAS1000XT. Remove the cable from J59 and during the ignition phase measure for 120 VAC between pins 7 & 9.
  - a. If 120 VAC is present problem is in the cable to the RAS 1000 XT or the J58 connector and internal harness in the Arc Starter.
  - b. If 120 VAC is present proceed to the next step.
4. 120 VAC to J59 comes from the relay board J8-3 with return on pin 11. On the Relay board, RF ON LED, D23, should be on during the igniting phase. If it is not skip to the next step.
  - a. If D23 is on and there is not 120 VAC at J8-3 & 11 then the Relay board is bad.

### Either Arc Starter

5. /RAS ON signal not on. CCM sends active low signal "/RAS ON" over the 40 pin ribbon cable on pin 16 to the Relay & Interface board. On the relay board RAS Control relay (K2) closes (RF ON LED, D23 on) sending 120 VAC to J8-3 with return on J8-11. From here it either goes to the HF transformer T2 (AC200XT) or to J59 as described above.
  - a. Measure the signal "/RAS ON" on pin 16 of the 40 pin ribbon cable relative to TP1 on either the CCM I/O board or the Relay board. If it is low (less than 1V) skip to step 6. Otherwise continue this step.

**NOTE!**

If the CCM thinks there is already a pilot it would not enable the HF. Pilot board has a current sensor that sends a differential analog pilot current level signal to the Relay board which in turn passes that signal to the CCM. On the Relay board D11 LED "Pilot Current Detected" or just "PILOT" lights if it sees a signal from the pilot board.

**Reasons why RAS Control relay would not close:**

6. Pilot current flowing. There actually is pilot current flowing somewhere. Unlikely as it would normally set the 208 fault but we have to rule it out.
  - a. Disconnect J41 on the Pilot board, if HF still doesn't fire and the Relay board Pilot LED, D11, is still on, it's due to a fault in the detection circuits.
7. Faulty detection circuit. There isn't any pilot current but a fault in the circuits measuring pilot current is indicating there is current.
  - a. Measure between pins 8 (-) and 9 (+) on the Pilot ribbon cable from Relay board J3 to Pilot board J42. If there is no pilot current it should be zero. Anything else indicates the Pilot board current sensor is faulty causing the Relay board D11 to be on. Replace the Pilot board assembly.
  - b. If the Pilot current signal on the pilot ribbon cable was zero, measure between pins 23 (-) and 25 (+) on the 40 pin ribbon cable between the Relay board and the CCM. This would also normally be zero if there is no pilot current. Anything else would indicate the Relay board is faulty.

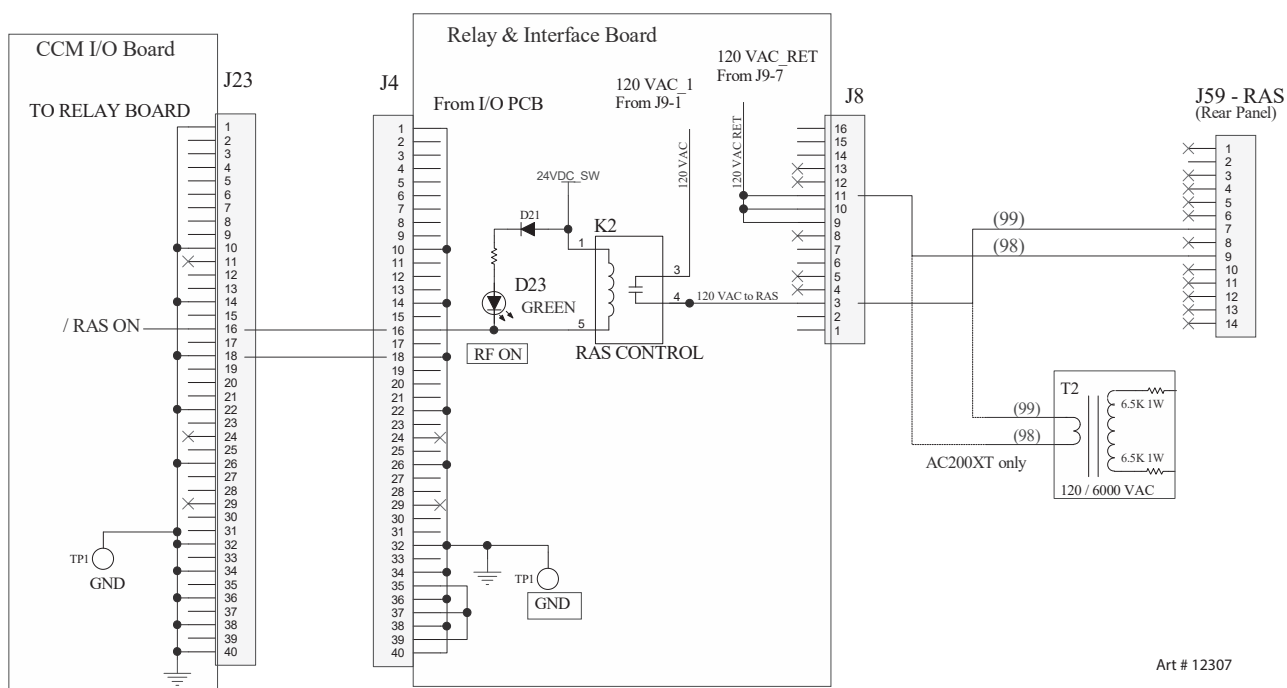

8. If "/RAS ON" signal is low on pin 16 of the 40 pin ribbon cable, relative to TP1 on the CCM I/O board, during the ignition time then we need to determine if the Relay board is defective. If /RAS ON signal is not low the CCM or the 40 pin ribbon cable may be defective.
  - a. If the Relay board RF ON LED, D23, is not on while the /RAS ON signal is low, then the Relay board is defective.
  - b. Is D23 is on, measure for 120 VAC on J8-3 to J8-11. If not present the Relay board is defective.
  - c. If 120 VAC is present at J8 during the ignition time go back and perform steps 2-4.

Troubleshooting Pilot Board problems.

1. The Pilot board is behind the CCM in the AC 300 XT, PAK 300i and all Ultra-Cut XTs or on the upper section of the second inverter module in an AC 200 XT and has two LEDs. The first one, D11, a green LED, indicates the board has bias power and should be on all the time when the unit is turned on. The second LED, D2, also green, is on when the pilot is enabled, that is the pilot IGBT switch is turned on. The pilot is enabled near the end of preflow time and remains on until the transfer is established or for 15 seconds after which a 102 code is displayed. If D2 performs as expected you know the CCM, Relay board and work current sensor are not causing the problem.
2. If D11 on the Pilot board is not on check if the 10 pin ribbon cable is connected between the Pilot board (J42) and the Relay board (J3). Measure for 24 VDC on the Pilot ribbon cable test connector pin 2 (+) and pin 10 (-). If 24V is present and neither D11 nor D2 lights then the Pilot board may be defective. Pilot board end of the ribbon cable could also be the cause.

What should happen on the Relay board is LEDs D12, work Current Detected & D11, Pilot Current Detected should both be off. When you apply START after 2 seconds (Preflow time) D7, Pilot Enable, should come on. Also D23, RF ON, should come on indicating the Arc Starter is being enabled. Normally D23 would only be on for a moment until pilot current is detected. Then D11 would be on (and D23 off) until arc transfer or pilot timeout (15 sec.) Since a pilot has not been detected D11 should not come on.

3. If the work current sensor is defective it could be telling the relay board (and thus the CCM) that there is already a transferred arc so no need for pilot. D12, a green LED on the Relay board, is on if work current is detected. If D12 is not on skip to step 5, otherwise disconnect J1, the work sensor connector. If D12 is still on the Relay board is defective.
4. If D12 goes out when J1 is disconnected, plug it back in and measure voltage from TP1 (common) to J1-1, should be positive 12-15VDC. Now measure J1-2, should be negative 12-15VDC. Now measure J1-3, should be 0 +/- 0.05V. If any of these are wrong disconnect J1 and measure again (on the relay board, not the harness). If still wrong the relay board is defective. Otherwise it's the work sensor.
5. Pilot Enable signal comes from the CCM on pin 15 of the 40 pin ribbon cable between the Relay board (J4) and the CCM (J23). It should be low, less than 2V relative to TP1 on either the CCM I/O board or the Relay board. You can also measure this on TP11 of the I/O board. If the signal does not go low when the pilot should be enabled at the end of preflow time then the CCM is probably defective. You can also jumper TP11 on the CCM I/O board to TP1, also on the I/O, to see if that will light D7, the Pilot Enable LED, on the Relay board. If it does, that further confirms the CCM is bad. If jumping TP11 to TP1 does not light D7 on the Relay board, the problem is likely the Relay board or possibly the ribbon cable.

### 103 Lost Pilot

Code 103 occurs when Pilot has ignited as sensed by the pilot current sensor on the Pilot board, but went out on its own while CNC Start is still active before the pilot timeout (85 ms. or 3 sec.).

Possible causes:

- Preflow gas pressure too high, for manual gas controls check cut charts for proper setting. For DFC 3000 check that the process is correct for the consumables.
- Cutting current set too low for the torch parts being used. Pilot current level is automatically set based on the cutting current. A low cutting current results in a lower pilot current that may not be able to sustain a pilot for higher current torch parts.
- Remote Analog Current Control switches set wrong can also result in lower than normal pilot current setting. See section on these switch settings under next section for code 104.
- Broken torch pilot wire.
- Defective Inverter module puts out less current than it's set for.

**104 Transfer Lost****Arc transferred to metal for at least 50 ms. then went out.**

Causes for 104 code:

- Cut demand set much lower than recommended for torch parts, i.e. 100A consumables in torch but cut current set for 30 or 50A (or zero). Current may be too low to keep arc on.
- Torch standoff too high for cutting process being used.
- Plasma gas flow too low due to a leak somewhere between the plasma regulator or the DPC 3000 and the torch. Check for leaks.
- Remote analog current control switches set wrong.
  - o If remote analog current control is being used, SW8-2 (CCM CPU PCB) is on and SW11 (CCM I/O PCB) is set to "A" (down) position, but no analog voltage connected to TB1-10 or J15-30 (CNC cable) then cut demand will be zero, pilot will be weak, depending on torch height it may still transfer but will immediately go out.
  - o If remote analog current control is not being used but either SW11 is set to the down position or SW8-2 is on also results in zero cut demand.
  - o If system is Auto-Cut XT, current control is an analog voltage from the GCM 1000 XT or the AC 200 XT front panel pot. The current control setting will be shown on the front panel 4 digit display. SW8-2 should be off and SW11 set to up position. With pot at max, check for 3.3V on CCM I/O PCB TP9 (TP1 common). While turning the pot toward minimum TP9 voltage should vary linearly to zero V.

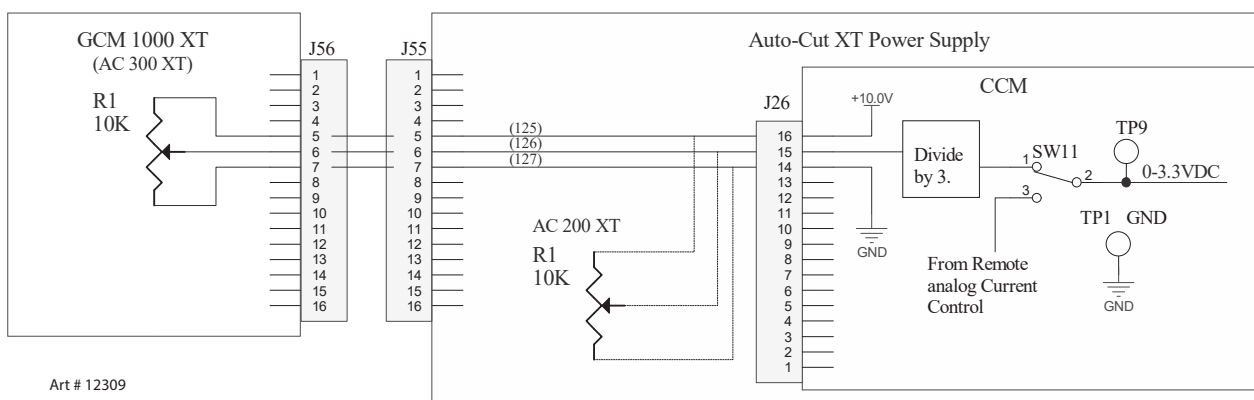
**105 Not Used. This is one of the reserved codes from the earlier product.****106 Pilot Timeout, no Transfer**

Pilot time is limited to either 0.085 seconds (85 ms.) with CCM SW8-1 off (default for pierce starting) or 3 seconds with SW8-1 on (used for cutting over holes, expanded metal, etc.). Arc must transfer before pilot time ends. Code 106 is set if no arc transfer (current in work lead) was sensed before pilot timed out. If the unit does not detect pilot current the arc starter will operate up to 15 seconds then set the 102 code. If you are getting 106 there is pilot current somewhere. If it's not visible perhaps it's inside the consumables or following some other part.

Causes for 106 code:

No Pilot Visible:

- Pilot inside the consumables. Most common cause is low or no plasma gas flow through the torch. You may be fooled into thinking you have plenty of gas flow but it may only be shield gas. For the Ultra-Cut torch remove the shield hose (small gray hose) from the DPC. For the GCM 2010, Auto-Cut or Pak 300i torches just turn the shield pressure regulator to zero. Place the gas control in SET or for the DFC 3000 load a different process to cause a new gas purge. Feel for plasma flow out of the torch, it should be a strong flow. If not there is a blockage in a hose or fitting or a solenoid in the TVA, DPC or GCM gas control isn't turning on.

## Visible Pilot:

- First the obvious, make sure the work lead is connected both to the work and the power supply. Also make sure the work itself is making good electrical contact with cutting table. If rusty or painted metal, you may need to clean a spot and attach the work lead directly to the metal.
- Torch too far from work.
- Cut current set too low for torch parts being used. Pilot current is set based on cut current. If cut current is too low pilot current will be lower and may not transfer at the height used for higher current consumables.
- Preflow pressure/flow too low.
- Remote Analog Current Control switches set wrong can also result in lower than normal pilot current setting. See section on these switch settings under section for code 104.
- Defective work lead current sensor circuit. If transfer is not sensed cut current remains at the lower starting level and pilot timer (85 ms. or 3 sec) will time out.

### 107 Tip saver fault. (Pak 300i and 1Torch option only)

CCM code V2.1 tip saver is active for torches with exposed tips (Pak300i and 1Torch option for the Ultra-Cut). Tip voltage, relative to work, is continuously monitored and if tip voltage drops below a certain voltage as it will if the tip contacts the work, cutting current is immediately reduced to a level, usually 35A-40A, that won't damage the tip. Current remains at this lower level as long the tip remains in contact with the work for up to 15 seconds. If before 15 seconds is up, the torch tip is lifted to normal cutting position the current increases to full current and normal cutting resumes. If the tip remains in continuous contact with the work exceeding 15 seconds the arc is extinguished and the code 107 is shown as the cause of the arc going out.

- Tip voltage is measured by the CCM via wire #53, J45-3 on the Pilot PCB to J24-2 on the CCM I/O PCB. An open connection here will set the 107 code after 15 seconds even if the tip isn't contacting the work.
- An open here will also cause the tip saver to fail to reduce the current so the tip will not be "saved". 107 code is not shown in this case as the system has no way to know the tip was contacting the work.

### 108 Tip to Electrode Voltage Fault

The Pilot voltage, measured between tip and electrode varies with different current and gas type, flow rate and consumable design.

Once the arc is transferred the pilot switch opens leaving the tip basically floating. The voltage then is determined by how much of a cold gas barrier surrounds the arc. Too much current or too little gas and the arc starts to contact the tip reducing the voltage difference between tip and electrode and leading to a double arc that destroys the consumables.

The CCM measures both electrode and tip voltage and calculates the difference. If the difference between tip and electrode is found to be less than a minimum voltage we stop cutting and set a fault for the 108 code. The normal tip to electrode voltage is different for different processes so the min value for each process is embedded in the cut charts when using the DFC 3000 or in the CCM code if using the GCM 2010 or for Auto-Cut XT gas controls (GCM 1000XT or the built in one in the AC 200 XT).

New for the Auto-Cut XT units is a switch on the rear of the power supply that needs to be set according to the plasma gas. If using an oxidizing gas (O<sub>2</sub> or Air) set it as indicated for those gasses (left if AC 200 XT or up for AC300XT) or if using a non-oxidizing gas (N<sub>2</sub>, H<sub>35</sub> or other inert gas) set it to the right or down as indicated for those gas types.. This switch adjusts the range of voltage for the gas type to better protect the torch. A wrong setting could result in false setting of the 108 code.

During piloting and ramping (the time from transfer until the current reaches full cut current), we lower the allowed tip to electrode voltage to about 80% of that allowed during cutting because the current is lower and the gas flow is lower during that time.

Causes for 108 code:

- Gas Flow/pressure too low for consumable parts being used.
  - o If gas source pressure is not well regulated it is possible pressure may be OK at times and drop too low at other times such as during a cut.
  - o A leak of the preflow/plasma gas after the pressure/flow control (GCM 2010, DPC, GCM 1000 XT) can reduce the pressure/flow to the torch because some if it is bypassing the torch, while seeming to have enough pressure/flow at the gas control.
- Cut current set too high for consumable parts being used.
- With DFC 3000 a faulty component would be expected to set a fault code in either the DPC or DMC. However, if a wrong process is selected which doesn't match the consumable type or if using a custom process where pressure has been set too low or current too high that could cause 108 without setting any faults in the DFC 3000.
- A broken pilot wire in the torch lead making intermittent contact can allow piloting or sometimes the torch can transfer using only HF (high frequency). This intermittent connection will upset the tip voltage measurement and can result in the 108 code. Symptom is - it may cut for a short time then fault. Check for an open/broken torch lead pilot wire.
- Physically shorted torch body between anode (tip) and cathode (electrode).

The fault resulting in a 108 code is measured while cutting. It is more likely a shorted torch body, depending on the resistance of the short, it will set code 208 (Unwanted Current) as that is measured prior to starting cut However, it must be considered as a last resort.

#### 109 Part Process not Configured.

This represents a status, not a fault. This is used with the DFC 3000 only. It means the operator hasn't loaded the cutting process from either the TSC 3000 or from the program embedded in the cutting table CNC controller. The solution is to load a process. The code will continue to be displayed until the CNC Start is applied at which time the code will clear.

#### 110 Not Used. This is one of the reserved codes from the earlier product.

### Group 2 – Plasma Power Supply codes

#### General:

#### LEDS

Several LEDs are used as indicators on the different inverter module boards. RED LEDs indicate faults. Green LEDs should be on for the most part. Green LEDs are: On the main board, D4-READY; On the Cap Bias Board, D6, -12V, D11 +12VP (primary referenced), D13, +12V; On the Control board D24, PWM will only be on when the inverter is enabled and its brightness varies with the duty cycle of the PWM.

Signals:

General description of some Inverter Signals passed to the CCM that can generate fault codes in Group 2.

“Ready” also called AC IN FLT (D4, READY LED, green, on Main Inverter board)

On the inverter main board we measure the input voltage. The 3 phases are rectified and lightly filtered to achieve an average voltage. Due to the light filtering a missing phase will also lower the average voltage so it will be detected. Voltage in the correct range turns on the READY LED D4 (on the far left of the main boards, in the upper part of the “B” section or lower part of the “A” section). Voltage outside the correct range or missing phase will turn D4 off.

An AC Input Fault by itself (no other faults occurring at the same time) will set codes in the 241-246 group depending on which inverter sees the problem.

INV FLT (D1, INV FLT LED, red, on the Inverter Control and Fault board)

Several things can cause Inv Flt (Inverter Fault). Inverter fault is indicated by an LED, D1 on the Inverter Control and Fault board. Inverter Fault, when it occurs, is latched on. The latch is reset next time the inverter is enabled unless it is still active in which case it is immediately latched again. Inverter Fault will set the codes 247-252 unless it's in conjunction with another fault in which case that fault code may be set.

Things that can set the inverter fault:

- The local (to the inverter) +12V & -12V bias supplies out of tolerance. There are LEDs on the Cap/Bias board that light indicating these bias supplies are present but don't verify they are in tolerance. It's not likely this would happen. More likely that fault related to the +/-12V the supply would be missing and it's LED not on.
- Capacitor imbalance. In a cap imbalance condition D3, red Led on the main board (lower left corner of bottom or "A" section and upper left corner of the upper or "B" section), will latch on.
- Primary over current. This is an over current condition in main switching transformer's primary. This will latch on but is cleared when the inverter is enabled unless it is still active in which case it is immediately latched again.
- Inverter over temperature sets the Fault signal and LED but has its own fault signal to the CCM. See OT Flt below.

OT FLT (D14, OT FLT, Inverter Control and Fault board)

- Inverter over temperature lights LED D14 on the Inverter Control and Fault board and will latch the fault signal and it's LED but also has its own separate fault so that will be reported as a code in the range of 253-258 or 259-264.

## PWR Present

- When power is first applied to the inverter (contactor closed) CCM checks for presence of the +12V bias on the Inverter Control and Fault board. If not present will set codes in the range of 265-270.

## IS\_ID (A, B, or C)

## VAC\_SEL (A or B)

### 201 Missing AC Phase

The System Bias Supply board contains circuits to detect if one of the 3 AC input phases is missing. Along with that it can also detect if the AC voltage is too low or too high. Three phase voltage is supplied from the input terminals through the ON/OFF Switch / circuit breaker CB1 to the System Bias board. The System Bias can operate on any 2 of the 3 phases to supply control power and fault detection.

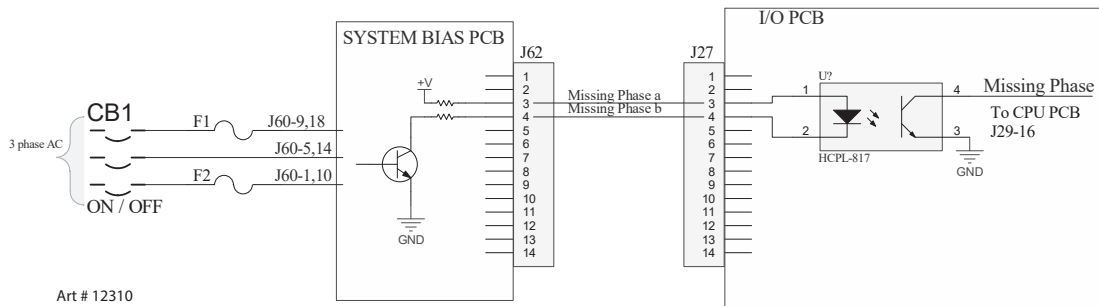

Normally when the phase is not missing the transistor is on which turns on the opto-isolator making the signal "Missing Phase" low.

Causes for 201, missing phase code. Codes are displayed two different ways, with an "L" meaning "Latched" or "Last", before the number meaning it was a problem but isn't right now or with an "E" meaning the problem exists now.

### L201 :

Most likely cause is an intermittent problem with the incoming power or possibly a loose connection on the power cord at the back or the Ultra-Cut or Auto-Cut plasma supply.

### E201:

- Phase missing from the wall fuse box, blown fuse.
- F1 or F2, 8A 500V slow blow fuses blown.
- CB1 one phase open.
- System Bias board defective.
- I/O board defective.

## Troubleshooting:

1. System Bias board has a red LED, D3, that lights if it detects a missing phase. If D3 is on, check J60 for all 3 phases.
  - a. If all 3 phases are not present at J60 check for incoming power, then the F1 & F2 fuses. Finally the CB1.
  - b. If all 3 phases present and about equal voltage then change the System Bias board.
2. If D3, Missing Phase LED, is not on check for voltage at J27-3 & 4 on the CCM. Normal voltage, with no missing phase, at J27 (or J62 on the System Bias board) pin 3 and pin 4, relative to I/O PCB ground. (TP1) should be between 10-14VDC with pin 3 being a couple volts higher than pin 4. If this is normal, problem may be in the CCM.
3. If the voltage at J27-3 & 4 is higher than 10-14VDC and up to 20-24VDC, make the same measurement at J62 pin 4. If still high there and you have confirmed all 3 phases are present at J60 then the System Bias is defective.
4. If the voltage at J62-4 is not high the wires between J27 and J62 may be broken.

**202-204 Not used. Reserved codes from the earlier product.****205 DC Output Low**

DC output (voltage) low means one or more inverter sections are enabled but the output voltage is below a preset voltage. Shortly after receiving the Start signal from the CNC, but before the end of preflow, both sections of IM#1 are enabled and CCM measures the power supply output voltage between negative (Torch) to positive (Work) at the output terminals. If this is less than a set value during preflow or if at any time during piloting or cutting it drops to below that value for a short time, the inverters are shut off and code 205 is set. 205 will almost always be indicated as an "L", not an "E" fault because as soon as it's detected the inverters are shut off and so no longer have the fault of low output voltage. Currently the low voltage value is -60VDC.

Causes of 205 code can include shorts outside the plasma power supply, shorts inside the plasma power supply and measurement errors.

- a. Short external to the plasma power supply:
  - The negative lead goes from the rear of the power supply to the remote arc starter or to the GCM 1000 XT in the case of the AC 3000 XT.
    - o Cable pinched in or exiting the power track
    - o Short inside the Arc Starter such as a wire coming loose and grounding to the chassis.
    - o Short inside the torch mounting tube.
  - Trouble shoot for external negative lead shorts by removing the lead from the rear of the power supply and try to start. It won't start but if you get the same 205 code the problem is inside the unit.
- b. Short inside the supply:
  - All the inverters outputs except that of IM1A are in parallel. If any inverter's output is shorted it will appear as a short across the power supply output.
 

Troubleshoot by removing all (or one at a time) of the inverter output connectors except those on IM1A. Then apply Start to the unit. If it starts now one of the other inverters had shorted output. To find the defective one reconnect one at a time until the fault reappears.

**206 Not used. Reserved codes from the earlier product.****207 Unexpected Current in the Work Lead.**

HCT1, a Hall Effect current sensor on the positive (work buss bar) measures the work lead current. Inverter section 1A is enabled during preflow time but there should be no current in the work lead before the pilot is ignited and before the arc is transferred to the work. If current greater than 8A is detected before or during preflow something is wrong.

1. 207 code before START applied:
  - Defective work current sensor, HCT1.
  - Defective Relay PCB
  - Defective CCM

**Defective Sensor**

- The work current sensor, HCT1, receives power, +15VDC and -15VDC from the Relay PCB. Both must be present for the sensor to work properly. Measure between Relay PCB TP1 (or J1-4) to J1-1 for +15VDC and to J1-2 for -15VDC.
- If either + or - 15VDC not present remove the J1 connector and repeat the measurement at J1-1 & 2 on the Relay board. If the voltage is now present the sensor is defective or shorted (the harness may be shorted). If voltages still not present, the Relay board is defective.

**Relay PCB**

- Relay board LED D12, Work Current Detected, will light if the current sensor signal exceeds 0.05V. If D12 is on, measure the sensor output signal at J1-3 with signal common on J1-1. This signal should be 0V +/- 0.04VDC. If greater than +/- 0.04VDC with no work lead current, the sensor is defective. If the signal voltage is within the limits and D12 is on, then the Relay board is defective.
- If D12 is not on and the 207 code is still active, either the Relay board or the CCM is defective.

**CCM or ribbon cable**

- The work current signal leaving the relay board is on the 40 pin ribbon cable (Relay J4 to CCM J23) pins 27 (-) & 28 (+). If the voltage here exceeds 0.1VDC with no work current the Relay board is likely defective. Another possibility is in the 40 pin ribbon cable either pin 27 or 28 is shorted to an adjacent pin. Otherwise the CCM is defective.

**2. 207 code after START applied (during preflow):**

- Short between power supply negative output and Work circuit.
- Short between power supply negative output and earth ground.
- Defective or incorrectly installed user supplied equipment such as torch height controls that make connections to power supply output.

Shorts are more likely to cause DC output voltage low (code 205). However, if the short has enough resistance it is possible to show code 207. To test, remove negative output cable and reapply Start. If 207 code does not appear problem is a short somewhere outside the power supply.

**User Installed Equipment**

For user installed equipment to cause 207 code it would have to be connected on the output (to the rear) of the current sensors. To test, disconnect user equipment and apply CNC START. If code 207 is gone user equipment was defective or connected incorrectly.

**208 Unexpected current in Pilot Circuit**

The Pilot board includes a current sensor to measure the pilot current. There should not be any pilot current until the inverters and the pilot board are enabled and the arc starter has fired to ignite the pilot. Pilot current or the signal indicating pilot current should not be present until the arc starter has fired.

Unwanted current signal due to defective sensor or defective circuit boards will most likely be present as soon as the power up sequence completes and will be indicated as an active fault, E208. An actual short allowing real current to flow in the pilot circuit will not occur until the inverter and pilot board are enabled near the end of preflow. This will result in the inverters immediately being shut off and displaying a "last" or "latched" fault, L208. An LED, D2, on the Pilot board lights when the Pilot Board is enabled.

**1. 208 code before START applied:**

- Defective Pilot board (current sensor circuit).
- Defective Relay PCB
- Defective CCM

## Pilot PCB

Pilot current signal is on the 10 pin ribbon cable (Pilot J42, Relay PCB J3) between pins 8 (-) and 9 (+). With no current, the signal should be zero +/- 0.05 V. Also the Relay board has an LED, D11, "Pilot Current Detected", which will light if the pilot current signal exceeds 0.15V. If the signal is not zero V. Pilot PCB is likely the cause. To be sure, disconnect the Pilot board ribbon cable from the Relay board at J3. If D11 goes out, the Pilot board was the cause. Double check by measuring pin 8 & 9 again. If it's zero V. now, the Pilot board is defective. If D11 is still on or pin 8 & 9 voltage still high check the Relay board.

## Relay Board or CCM

If D11 on the Relay PCB is still on after the previous tests, measure the output to the CCM on the 40 pin ribbon cable (Relay J4 to CCM J23) between pins 23 (-) and 25 (+). It should be less than 0.1V. If not, the Relay board is bad. If voltage is zero then the CCM is defective.

## 2. 208 code comes on during preflow:

IM#1 and the Pilot board are enabled near the end of preflow. To have unwanted current there must be a path (short) for current to flow between the inverter negative output (negative cable/torch electrode) and the Pilot return/tip before the arc starter is enabled for pilot ignition.

Possible causes are:

- Short between electrode and tip due to mismatch of consumables, damaged consumables or foreign matter between tip and electrode. An electrode at the end of its life may lose material that can short between electrode and tip.
- Defective or incorrectly installed user supplied equipment such as torch height controls that make connections to power supply output.
- Short between power supply negative output cable and pilot cable.
- Shorted torch body.

Troubleshooting:

1. Remove and insulate (may have voltage on it) the pilot cable from the rear of the unit. Attempt to pilot. If no 208 code shows, it confirms problem is outside the power supply.
2. Remove and check consumable for damage, cleanliness and missing (gas dist, etc.) or wrong components.
3. Disconnect user supplied equipment and see if fault still exists.
4. Inspect Arc Starter for broken/disconnected wires or burnt components.
5. Inspect inside the torch mounting tube for shorts.
6. If all else fails disconnect the pilot wire from the back of the torch head. Insulate it well or keep it away from any metal, it may have HF (high frequency) on it when you try to start. Try to start, if the 208 is gone now the torch head is shorted.

**209 Not used. Reserved codes from the earlier product.****210–211 Output current, measured by the work lead current sensor, is too high (210) or too low (211).**

These are warnings and do not shut down the process but may explain poor cut quality or poor parts life.

Individual inverter sections have their own current sensors and the work lead has a current sensor whose signal should equal the sum of the individual inverter sections. Each section is set to output a certain current based on its "demand" signal. If the current differs from the total "demand", sum of the individual demands, the individual sections are checked to determine if their output is correct compared with their demand signals.

If the individual sections are correct but the work current sensor signal differs from the total demand by more than 16% code 210 (too high) or 211 (too low) is displayed.

If an individual inverter section was found to be in error causing the total current to be wrong, a different code would be displayed in the range of 212 to 223 depending on which section was at fault.

Possible causes for work current signal too high:

- HCT1 Work Current Sensor
- Relay PCB
- CCM

Possible cause for work current to low.

- All the above plus a short to chassis caused by:
  - User installed equipment connect behind the current sensor that makes a connection to work or earth allowing current flow to bypass work sensor.
  - Inverter + output shorted to chassis.

Troubleshooting:

1. For current too low due to a short disconnect work lead from back of unit. Check for continuity to chassis, there should be none. Inspect for incorrectly connected user equipment.
2. If no shorts were found or if fault was current signal too high see section on code 207 for detailed description of the power and signal paths for the work lead current sensor.
3. In the section on code 207 for Relay PCB it describes measuring the work current sensor signal when there is no current. The signal should be zero and we assume it is or else you should have gotten the 207 code. If the zero current signal is correct but there is an error while cutting, measure the signal on the 40pin ribbon cable (Relay board J4 to CCM J23) pins 27 (-) & 28 (+). The signal voltage should equal the cutting current \* 0.0266. For example for 100A ( $100 * 0.0266$ ) = 2.66V.
  - If this signal is correct the fault is the CCM
  - If it's not correct the error may be in the Relay board or sensor. Follow the instructions for code 207 to measure the voltage to and signal from the current sensor at J1 on the Relay board. The signal voltage should equal the cutting current \* 0.0133. For example for 100A ( $100 * 0.0133$ ) = 1.33V. For 400A would be  $400 * 0.0133 = 5.33V$ .
  - If power and signal are correct Relay board is faulty. If not correct the HCT1 work current sensor is bad.

### **212-223 Incorrect output from an inverter section.**

Work current high or low due to wrong output from one inverter section. Individual code indicates which section.

Causes may be:

- The named inverter section output connector, J102 A or B, is not plugged in or is damaged.
- Ribbon cable with bad connection, perhaps not fully locked in place at either the inverter or the CCM.
- Defective inverter section.

Troubleshooting:

1. If it reports the current of an individual inverter section is too high, the problem is the inverter.
2. If the report is current too low (which included no current) check the connections.
3. The ribbon cable for the first inverter section (IM#1A) must connect to that section only but if there are 2 additional sections, unit is 200A or greater, swap the ribbon cable going into those sections.
  - a. If it now reports a different section as bad, the one whose cable was moved, then the original section was bad.
  - b. If it still reports the original section the ribbon cable or the CCM is bad (unlikely).
  - c. Swap both ends of the ribbon cable with one next to it. If still reports the original section then the problem is with the CCM if not then it's the ribbon cable.
4. If it's the first inverter section or it's a 100A unit so there's no other inverter to swap cables with, replace the inverter.

Additional hint: Inverter control PCBs have a green LED, D24, PWM ON, that lights when that section is enabled and has a demand signal. The LED brightness is relative to the output so may be very dim if output is low. If that LED doesn't light may indicate a defective inverter (control board).

**224 Inverter 1 not found.**

There must be an inverter connected in the 1st section, 1A, to be able to pilot. During the power up sequence, before power is connected to the inverters, the CCM does a continuity test to see if its section 1A ribbon cable (J31 on CCM) is connected.

Causes & troubleshooting:

- As this is just a continuity test it is very unlikely to be a bad inverter. Most likely a poor connection or defective ribbon cable.
  - o Check ribbon cable connections at both ends of INV1A to CCM J31 (1A) cable. Make sure it is plugged into J31, the top connector, on the CCM.
  - o Plug a different inverter cable into J31, doesn't matter which one for this test as long as it's plugged into an inverter on the other end. If still gives 224, "Inverter 1 not found" fault, it's a bad CCM. Otherwise it's the ribbon cable.

**225-230 Inverter Revision and CCM incompatible.**

If sometime in the future we should make a change to the inverter making it incompatible with older CCM we have included a hardware key that would change to indicate this. During the power up sequence, before power is connected to the inverters, the CCM does a continuity test to determine what is the hardware key configuration. The key uses 3 lines of the CCM to inverter ribbon cable which are named IS\_ID\_A, IS\_ID\_B, IS\_ID\_C (on pins 12, 13 & 14) and checks for continuity to a 4th line OUTCOM (pin 9). The test consists of applying voltage to OUTCOM and looking for that voltage coming back on the 3 ID pins. The present configuration has all 3 lines connected to OUTCOM so all 3 should be high.

To get the 225-230 code now when we don't have any incompatible revisions would most likely be a bad connection in the ribbon cable between the CCM and the inverter or a defective CCM (unlikely).

- On the inverter section swap the ribbon cable with that of a different inverter section. If fault remains unchanged, still calls out the original inverter section, the problem is with either ribbon cable or CCM.
- On the inverter end put the ribbon cables back in their original positions. Now swap suspect ribbon cable with another one on the CCM. If the fault now moves to a different section it's the ribbon cable. If it remains with the original section the problem is the CCM.

**231-236 Inverter VAC Mismatch.**

Different inverter modules are manufactured for 480VAC, 380-415VAC & 208-230VAC operation voltages. There is a key, called inverter ID, read through the inverter's ribbon cable, to identify which voltage range the inverter is designed for. The unit itself is wired differently for the different input voltages and part of that includes a jumper at J61 on the System Bias board that indicates to the System Bias board what voltage the unit is wired to accept.

At power on, the System Bias board measures the incoming voltage, determines what input voltage range it fall into and sends that range information to the CCM. Before Applying power to the inverters by turning on the input contactors, the CCM checks that each connected inverter is of the correct voltage matching that of the System Bias board. The inverter ID's are read from the lowest section to the highest so in all cases if it truly is a wrong voltage inverter it should call out the A section whose code is read first. A VAC mismatch of a B section is likely another problem.

Possible causes:

- Wrong voltage inverter (very unlikely but easy to check).
- System Bias board wrong J61 jumper (unlikely but easy to check)
- Defective inverter.
- Ribbon Cable
- CCM
- System Bias board defective.

Troubleshooting:

1. If System Bias board has either the wrong jumper or is defective it will call out the first inverter section, code 231, because all the inverters won't match the incorrect signal and 1A is checked first.
  - a. For the jumper Wire #48 should be connected from J61-1 to:
    - i. J61-2 for 208-230 VAC
    - ii. J61-3 for 400 VAC
    - iii. J61-4 for 480 VAC

Check for proper connection and continuity.

- b. System Bias may be defective reporting the wrong voltage ID. On the output of the System Bias board at J62 measure relative to TP1 or ( J62-8, 24VDC\_RET) to J62-12 for signal /VAC\_IDAb and J62-14 for signal /VAC\_IDBb. The 2 signals should read according to this table. "0" = 10-12V; "1" = 24V.

signal	230V	400V	480V	ERR
/VAC_IDAb	0	1	0	1
/VAC_IDBb	0	0	1	1

2. Defective inverter, ribbon cable or CCM.
  - a. On the inverter section swap the ribbon cable of the inverter section whose fault was indicated with that of a different inverter section. If fault remains unchanged, still calls out the original inverter section, the problem is with either ribbon cable or CCM. If fault changes to the different section, the one the ribbon cable was swapped with, then it's the inverter that's defective.
  - b. If the fault remained unchanged in Step A, on the inverter end, put the ribbon cables back in their original positions. Now swap suspect ribbon cable with another one on the CCM. If the fault now moves to a different section it's the ribbon cable. If it remains with the original section the problem is the CCM.

**237 Too Few Inverters Found**

There must be a minimum of 2 inverter sections present to operate. We know the ribbon cable for inverter section 1A is connected or else we would have code 224. During the power up sequence, before power is connected to the inverters, the CCM does a continuity test through the ribbon cable to see if an inverter is connected. If it doesn't see continuity with at least one other inverter it assumes none are connected.

Possible causes:

- Ribbon cable disconnected or defective.
- Inverter defective
- CCM defective.

Troubleshooting:

1. Check that all cables are connected, latches locked down, at both the inverter and CCM ends.
2. If this fault occurs it's most likely on a 100A unit which only has one section (1B) in addition to the 1A section. If there were 2 or more additional sections it's extremely unlikely all ribbon cables or CCM connectors would be defective.
  - a. Swap the ribbon cables of the inverter section 1A and 1B. If fault remains unchanged, still 237, problem is with either ribbon cable or the CCM. If fault changes from 237 to 224 indicating inverter 1A missing, then it's the inverter that's defective.
  - b. If the fault remained unchanged in step a., on the inverter end put the ribbon cables back in their original positions. Now swap suspect ribbon cables on the CCM. If the fault now changes it's the ribbon cable. If it remains the same it is the CCM.
  - c. If there are 2 or more ribbon cables in addition to the one on section 1A then CCM is seeing none of them connected which indicates the CCM is faulty.

**238 System Bias voltage identification is invalid.**

At power up the System Bias board measures the input voltage and sends signals to the CCM indicating which range of voltage it has detected. See section 231-236 for details. If one of the 3 voltage ranges, 208-230V, 380-415V or 480V isn't identified then both ID signals are high resulting in an invalid signal.

Possible causes:

- Unit is connected to voltage below the 208-230V range or above the 480V range. (unlikely unless there is a problem with the incoming voltage.)
- Defective System Bias board
- Bad connection between System Bias output J62 and CCM input J27 on the I/O board.
- Defective CCM

Troubleshooting:

1. Measure all 3 phases of the input voltage and confirm they are within the tolerance specified in the unit manual.
2. Refer to section 231-236 Inverter VAC Mismatch and perform troubleshooting in step 1.b. If the 2 signals don't match the incoming voltage, if both are high, then the System Bias is defective.
3. If step 2 was OK make the same measurement at J27 on the CCM I/O PCB. If OK here the CCM is defective. Otherwise inspect the connections at J62 and J27.

**239 AC Voltage High**

**Voltage OK** -- At power up the System Bias board measures the input voltage and determined if it is within the range of voltage set by the J16 jumper. See section 231-236 Inverter VAC Mismatch Troubleshooting step 1.a for details of the jumper. Normally when the input voltage is OK the System Bias board turns on a relay K1 on the left die of the board to apply power to the T1 Auxiliary transformer. D44, a green "Transformer ON" LED, will light when K1 is energized. T1 provides power to the gas controls and the TSC 3000 as well as the pumps and fans.

**Voltage High** -- If the AC voltage is determined to be too high it lights D4, ACV HIGH, a red LED on the System Bias board, and sets the signal "AC V HIGH b" on J62-6 to a "high" about 24VDC (normal for a "low" here is 10-14VDC). To prevent the possibility of excessive voltage applied to several items (gas controls, pumps, fans etc.) K1 is opened removing power from T1 and D44 goes off. If it's more than a momentary glitch the gas controls and the TSC 3000 (if used) will reset. Communication with the cutting table may be interrupted. With the DFC 3000 Auto Gas Control and perhaps the cutting table control, the process will have to be reloaded.

D4 is on and the signal "AC V HIGH b" is high only while the voltage is actually high. The signal "AC V HIGH b" does not latch on.

If the fault is E239 that means it is currently active, that is, currently detected as being too high. If it's L239 that means the voltage too high previously but it is not too high now. Applying START will clear the fault unless it becomes active again.

The voltage that triggers an AC Voltage High fault is above 550V for 480VAC line; above 470V for a 380, 400 or 415V nominal line; above 270V for a 208 or 230VAC line.

Possible causes:

- Incoming voltage is or was too high.
- Bad connection at J62 or J27
- Bad connection at J61 jumper
- System Bias board defective
- CCM defective.

## Troubleshooting:

1. If the fault is L239 applying START will clear the fault unless it becomes active again. An occasional problem may be due to incoming voltage swells (voltage increases lasting from ½ cycle to as much as a minute). Usually, if the plasma is at fault the problem will be present all the time.
2. It is unlikely that an open connection on the J61 jumper would result in a 239 fault, more likely to be a Voltage Mismatch fault. However, if it's intermittent at exactly the right time, perhaps not fully plugged in, it could possibly show up as 239. Check J61.
3. If the incoming voltage is OK and the problem persists it may be the System Bias board, the CCM or the connection between J62 and J27.
  - a. If the incoming voltage is OK and D4 is on or signal "AC V HIGH b" on J62-6 is "high" (about 24VDC, relative to TP1 or J62-8 ) the System Bias board is defective.
  - b. If D4 is not on and the signal "AC V HIGH b" on J62-6 is "low" (about 10-14VDC, relative to TP1 or J62-8) then System Bias is OK and problem is in the CCM.
  - c. If J62-6 is near zero volts there may be bad connection between J62-6 and J27-6 or J62-7 and J27-6.

**240 AC Voltage Low**

Refer to the first paragraph for code 239 for explanation of what should happen when the input voltage is correct.

Voltage Low -- If the System Bias board determines AC voltage is too low it lights a red LED, D14, ACV LOW, and sets the signal "AC V LOW b" on J62-10 to a "high", about 24VDC (normal for a "low" here is 10-14VDC). Power is not removed from T1 as low voltage won't damage anything, However, if it's too low for too long, some things like contactors, AC solenoids, the gas controls or TSC 3000 may stop working. A low voltage, if it's low enough, may also light D3, the red Missing Phase LED. This does not indicate the phase is actually missing.

The voltage that triggers an AC Voltage Low fault is 380V for a 480VAC nominal line; 300V for a 380, 400 or 415VAC nominal line; 175V for a 208 or 230 VAC line.

## Possible cause:

- Incoming voltage is now, or was previously, too low.
  - o Power distribution wires or power cord too small for the load.
  - o Loose or high resistance connection somewhere in the power distribution or power cord connection.
- Bad connection at J62 on the System Bias board or J27 on the CCM.
- Bad connection at J61 jumper on the System Bias board.
- System Bias board defective.
- CCM defective.

## Troubleshooting:

1. If the fault is L240, applying START will clear the fault unless it becomes active again. An occasional problem may be due to incoming voltage dips or sags (voltage drops lasting from ½ cycle to as much as a minute). Usually, if the plasma is at fault, the problem will be present all the time. After ruling out everything else we may have to attach a monitor to the power input to determine if this is the problem.
2. Voltage can be OK when not cutting or cutting at lower currents but at higher current too much voltage may be lost due to undersize power cord or distribution wires.
  - a. Measure the voltage while cutting at higher current to determine if the drop is excessive.
  - b. Verify all power connections are clean and secure.
  - c. Verify correct wires size for the current draw per the recommendations in our manual as well as the local electrical codes.
3. It is unlikely that an open connection on the J61 jumper would result in a 240 fault, it is more likely to cause a Voltage Mismatch fault. However, if it's intermittent at exactly the right time, perhaps not fully plugged in, it possibly could show up as 240. Check the jumper at J61.

4. If the incoming voltage is OK and the problem persists it may be System Bias, CCM or connection between J62 and J27.
  - a. If the incoming voltage is OK and D14, ACV LOW, is on or the signal "AC V LOW b" on J62-10 is "high" (about 24VDC, relative to TP1 or J62-8 ) the System Bias board is defective.
  - b. If D14 is not on and signal "ACV HIGH b" on J62-10 is "low" (about 10-14VDC, relative to TP1 or J62-8) then System Bias is OK and problem is in the CCM.
  - c. If J62-10 is near zero volts there may be a bad connection between J62-10 and J27-10 or J62-7 and J27-7.

#### 241-246 Inverter Section Input Voltage Error.

The System Bias board checks for input voltage high, low or missing a phase from the power coming in from the power cord. It is unlikely but not impossible that a problem with the incoming power could result in 241-246 codes. The 241-246 codes more likely point to problems with the power into or within a single inverter section or in the case of missing phase it may be the contactor that supplies up to 3 inverter sections.

Once the input contactors close, applying voltage to the inverters, they test for input too high or too low and for missing phase. When the input voltage is in the correct range, a green LED, D4, named READY, lights on the left side of the main inverter board. If D4 is not on, either the input voltage is out of range or the inverter is defective.

You can still get the 241-246 code with a missing phase with the READY LED on. The LED will be going on and off rapidly but appears to the eye to be on. In this case you can measure the signal on the ribbon cable. The signal previously called READY is now called AC\_INPUT\_FLT. It is a differential signal on pins 1(+) & 2(-) of the inverters 30 pin ribbon cable. If the AC input is correct you should read 5-6V between the pins. If AC\_INPUT\_FLT is true voltage on pins 1 & 2 will be less than 2V.

Some of the other faults such as Inverter Fault and Over Temperature also set the AC\_INPUT\_FLT (not Ready). However, they will latch on associated LEDs or set different fault codes. In the event of an Input Voltage Fault the CCM does not remove power from the inverter.

Things that can cause Input Voltage Fault codes:

1. Intermittently having the power drop out on one or more phases for at least 1 ms. a longer term loss would more likely trigger a different fault. If it's the incoming power it would be likely not always be the same inverter.
2. Phase missing or intermittent to a specific inverter the fault would always call out that inverter.
3. Intermittent connections on the fault signal internal to the inverter.

#### 247-252 Inverter Fault

Once the input contactors close applying voltage to the inverters several tests are performed. The Inverter Fault signal latches on so even if the cause has gone away you can see that there was a fault as indicated by red LED D1, INV FLT on the inverter Control & Fault PCB. It is reset by applying start signal or cycling power. If the fault is still present it will come back on.

Things that cause an inverter fault:

- One or more of the local bias supplies (+/-12VDC) failed or out of spec. Green LEDs on Cap Bias board labeled +12V (D13) & -12V (D6) indicate the supplies are present but not necessarily that they are in tolerance.
- Input capacitor voltage imbalance indicated by D3 CAP IMBALANCE LED (red) on left side of main inverter board. Applies to units with series connected capacitors (380-480V units).
- Too much current in the main transformer (switching transformer) primary, D32, PRI OC LED (red), on inverter control board.

INV\_FLT is a differential signal on pins 3(+) & 4(-) of the inverters 30 pin ribbon cable. If there is not a fault you should read 5-6V between the two pins. If INV\_FLT is true voltage on pins 3 & 4 will be less than 2V.

Each inverter section (IS) contains one or more temperature sensors. If any of these detect an over temperature condition it activates the signal "OVERTEMP\_FLT" going to the CCM over the inverter sections ribbon cable. Inverters semiconductors (transistors and diodes) are liquid cooled. Anything that increases the coolant temperature too high can cause overheating of the inverters. The inverters magnetics (transformer & inductors) are air cooled by the same fan(s) that cool(s) the liquid.

Possible causes:

- Cooling fan(s) not operating.
- Disrupted air flow.
- Defective inverter module.
- Inverter Ribbon cable bad connection.
- Defective CCM.

Originally 100 and 200A units had 2 smaller fans while 300 & 400A used a single larger fan along with a larger radiator. More recently, the single larger fan may be used in the 100 & 200A as well.

Troubleshooting:

1. Confirm that air is exhausting from both the top (top fan) and bottom (bottom fan of units with 2 fans) of the opening in the right side panel. As the fan(s) are behind the radiator it's hard to see them to confirm they are turning but perhaps you can use an inspection mirror. Refer to section for code 403 for troubleshooting defective fans.

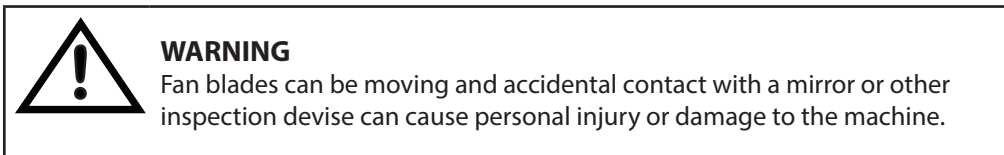

2. Leaving the side panels and cover off, especially the left lower side or the top cover will reduce the air flow. Also if the radiator fins become clogged with dust it will reduce air flow. Clean the radiator periodically by blowing air into it to clear dirt from the fins.

The CCM measures the ambient temperature where the cooling air enters the louvers on the left side of the front panel. If an inverter goes over temperature and we have determined that the ambient exceeds 40 deg C we will get one or more of the high ambient codes, 252-264. The sensor, TS2, is a NTC (Negative Temperature Coefficient) resistor whose resistance varies with temperature. It is mounted on the inside of the front panel next to the louvers on the left. To access it requires removing one or more of the inverter modules. If the ambient is high but no inverter is too hot there is no fault.

Possible causes:

- Ambient is too high.
- Cooling fan(s) not operating.
- Disrupted air flow.
- TS2, Ambient temperature sensor, shorted (very unlikely) or otherwise defective.
- Defective Relay board.
- Defective CCM.
- Defective Relay board.

Troubleshooting:

1. If room temperature exceeds 40 deg C, cool the room, or operate the unit at reduced duty cycle or lower current.
2. Confirm that air is exhausting from opening in the right side panel. As the fan(s) are behind the radiator it's hard to see them to confirm they are turning but perhaps you can use an inspection mirror. Be careful not to get the mirror or your hands into the blades. 100 & 200A units have 2 smaller fans, 300 & 400A have one larger one.

3. It is unlikely these high ambient temperature codes would be set before some other temperature related code but just in case we'll note that leaving the side panels and cover off, especially the left lower side or the top cover will reduce the air flow. Also the radiator fins clogged with dust will reduce air.
4. To test TS2 remove J2 from the Relay board and measure the resistance between pins 4 & 6 of the J2 harness connector. The resistance varies from about 33K ohms at 0 degrees C to about 12K ohms at 20C to 5.3K ohms at 40C.
5. If TS2 is within the correct range the problem may be with the Relay board or the CCM.
  - a. The output from the relay board going to the CCM is on pin 30 of the 40 pin ribbon cable (J4 of Relay board to J23 of the CCM I/O board). It is an analog voltage that should range between 0.44V at 0 deg C to 1.6V at 40C. If it is confirmed that the room ambient is not above 40C and Ambient temperature signal at pin 30 is higher than 1.6V then the Relay board is defective.
  - b. If Ambient temperature signal at pin 30 is OK, less than 1.6V, and the room ambient is not above 40C then the CCM is bad.

### 265-270 Inverter No Input Power

There are several digital signals on the ribbon cables between the inverter sections and the CCM that involve some level of voltage. These include AC\_INPUT\_FLT\, INVERTER\_FLT\, OVERTEMP\_FLT\ and POWER\_PRESENT. Normally all of these should be high. Before power is applied to the inverter modules the CCM has already performed a continuity check to see if that section is in place and it's ribbon cable connected (code 224 & 237). As soon as power is applied to the inverter modules the CCM checks these 4 signals and, having already confirmed there is an inverter whose ribbon cable is connected. If it finds none of the signals have voltage, it assumes there is no power into the section or something is wrong with that inverter section's bias power.

Possible causes:

- The 3 input phases, J103-105 to that inverter section not connected.
- The circuit breaker CB2 providing the 120 VAC to the contactor (and Remote Arc Starter) has tripped.
- The contactor powering that section (and others) defective.
- Relay board defective.
- Inverter defective.
- CCM defective.

Troubleshooting:

1. Check that the input power cables are connected to the inverters.
2. Check if the contactor for that section (W1 for 1A, 1B, 2A; W2 for 2B, 3A, 3B) is energized.
  - a. There is a rectangular section in the middle of each contactor top that can be used to attach auxiliary contacts. This can also be an indicator of contactor operation as it pulls in when the contactor is energized.
  - b. Check for CB2 on the rear panel being tripped. The white button marked "5" indicating it's 5 amps, will pop out if tripped. Reset it and if it pops out again something (contactor coil?) may be shorted.
  - c. Measure for 120 VAC on the contactor coil. If present, but the contactor isn't pulled in, it's probably a defective contactor.
3. On the Relay board D22, CONTACTOR ON LED (green) next to relay K1 lights if K1 is being told to energize.
  - a. If it's on check for 120 VAC between J8-1 and J8-9. If present the relay board is OK.
  - b. If D22 is on but 120 VAC is not present at J8-1 and J8-9 (make sure meter is set for ACV) then the relay board is defective.
  - c. D22 is not on, go to the 40 pin ribbon cable test connector and measure voltage on pin 17 (relative to TP1 on either the Relay board or the CCM I/O Board). It should be low, less than 1 volt. If it is the relay board is likely bad. If it's high, about 24VDC then the CCM may be bad, not telling the contactor to turn on.

4. The inverter section may be defective with a bad bias supply. Swap the inverter end of the ribbon cable with one next to it.
  - a. If it now reports a different code, that of the inverter that was swapped with, then the original section is bad.
  - b. If it still reports the same section even though the ribbon cable was swapped then the CCM is bad.

## 271 Inverter ID Reading Fault.

Refer to section for codes 225-230 for a description of the ID signals. If this code appears it means one of these ID signals has gone false some time after power up.

Possible causes:

- An intermittent ribbon cable or one not fully latched in place.
- EMI interference.

Troubleshooting:

1. First recycle power to see if the fault is still there. It may now show up as one of the 225-230 codes which will indicate which inverter.
2. Determine when the code shows up. If it is EMI it may not happen every time but if, when it happens, it is always at the beginning of piloting, it may be EMI interference. Check the system ground cables and if an AC200XT check the torch shield connection to the unit rear panel.
3. If it happens intermittently during cutting or idling it might be an intermittent ribbon cable. This code does not say which inverter section so you have to check each ribbon cable for proper connection on each end. It's highly unlikely for a ribbon cable to be intermittent but if you have more than 2 sections try disconnecting one section at a time and cut at lower current. See if you find one that causes the problem and if so replace that ribbon cable.

## Group 3 codes relate to the GAS Controls Status and Communication Protocol

Also refer to GCM 2010 Status Codes at the end of this Group 3 codes section.

### 301 Gas Control Communication Fault

No signal detected over the fiber-optic link from the gas control. In the case where there are additional devices other than Gas Control connected to the CANBUS this code would indicate the Gas Control is having communication problems while the other CANBUS devices are OK. We don't currently have any other devices on the CANBUS so it is more likely that code 501 will be what is set. In any case troubleshooting is the same as for 501.

Possible cause:

- Most likely cause is dirty or defective fiber-optic cable or connector.
- Cable to GCM 2010, DMC or DPC not connected or broken.
- Defective control board or power supply in the Gas Control
- Defective CCM

Troubleshooting:

1. Check that the fiber-optic cable is fully plugged in to both sockets. Clean the cable ends with a soft cloth and blow out the sockets with air.
2. Check gas control cables. If any of the gas control cables are not connected there will be no communication as there will be no power to the control. This may show up as a 301 or 501 code. Also if the cable is broken or defective such that the gas control is not enabled it may have power but in the case of the DMC or DPC its fault light will blink error 101 while the CCM will only detect that there is no communication and it will show 301 or possibly 501.

### 302 Gas Control communications reply fault

Communication has been established but Gas Control did not reply to a request from the CCM in the time allowed. Likely cause is Fiber-optic problems (see code 501) or if problem persists defective Gas Control main PCB.

**303 Gas Pressure fault**

Gas pressure faults only show up when you try to start the torch, not during purging or setting flows .

With the Auto-Cut 200 XT and the Auto-Cut 300 XT and PAK 300i (GCM 1000 XT), the gas pressure sensor is only on the plasma gas and is in series with Run/Set switch. A 303 code here indicates either plasma gas missing or very low pressure, less than 50 PSI, or RUN/SET switch is in SET position.

Starting with GCM2010 revision AG we measure inlet pressure of both plasma and shield gas at the inlet of the gas selection manifold. If pressure is either too low or too high it sets 303 code. Earlier revision should not display 303 code. GCM2010 will display which gas is the problem and its actual pressure. The pressure at the point where it is measured should be in the range of 100-135 PSI. Exception is for shield gas if the Gas switch is set to Pressure then the min pressure can be 85 PSI.

In the GCM 2010 Gas Control, on the main PCB, measure between test points TP1 (ground) and TP18 (shield) and TP19 (plasma) to measure the output of the pressure sensors. Voltage should be between 2.6V to 3.5V for 100-135 PSI. With shield switch set to pressure low limit is 2.1V. Whichever gas is outside those limits will be the one causing the fault. Remember the pressure may drop during operation, set the code, then recover displaying L303 when you are measuring it.

- To test for faulty pressure sensor or inadequate gas supply with too much restriction. On the GCM 2010 place the Mode switch to SET Plasma & Shield, turn the mechanical pressure regulators to max pressure and compare mechanical gauges with the pressure display. If the pressure display doesn't approximately match the gauge the sensor is likely defective. If the gauge and the pressure display both show low pressure the supply to the gas control has too much restriction. Perhaps the hose is too long or too small.

**304 Gas Control not ready**

This is the normal code when the gas control is conducting a purge at start up or when the process is loaded or changed or when the plasma system has been disabled and is returned to "Enable". If it is a GCM 2010 the Mode switch may not be set to the RUN mode.

Code 304 combined with 204 & 402 when the Plasma Enable on the GCM 2010 gas control is set to disable can indicate a fault in the CCM I/O PCB. When switching back to Enabled the pump will not restart so continues to display 4-2 indicating no coolant flowing.

Normally the code during a disable should be 101. Circuits on the I/O PCB detect the Plasma Enable is disabled and send signal to the microcontroller in the CCM. If a fault in the CCM prevents that signal from getting sent to the microcontroller it doesn't know the system is disabled so it sets these other 3 codes.

**305 Gas Control Protocol Error**

Application error or firmware incompatibility fault. Consult factory for latest firmware update. Possible electromagnetic interference from the Arc Starter; inspect grounding, bonding, and isolation.

**306 Not Used. This is one of the reserved codes from the earlier product.****307 Gas Control returns wrong command sequence.**

Firmware incompatibility. Consult factory for latest firmware update. Possible electromagnetic interference from the Arc Starter; inspect grounding; bonding; and isolation.

**308 Mismatch between the CCM and gas control type.**

The Auto-Cut XT CCM is designed to work with the GCM 1000 (AC 300 XT) or the built in gas control of the AC 200 XT. Attempting to use a GCM 2010 or DFC 3000 Auto Gas Control on an Auto-Cut will result in a 308 code. Similarly attempting to use a CCM from an Auto-Cut XT in an Ultra-Cut XT supply will also result in a 308 code.

**309 Gas Control Communication reply fault.**

Relay doesn't match what was requested. Possible firmware incompatibility. Consult factory for latest firmware update.

Possible electromagnetic interference from the Arc Starter; inspect grounding; bonding; and isolation.

These different codes displayed on the power simply indicate one of the Auto Gas modules (DPC for codes 310 or 311; DMC for 312 and 313 could be either) is reporting a fault. You need to refer to the specific modules blinking red LED status indicator and the Status code tables for more information.

**GCM 2010 Status Codes**

GCM 2000 has an LED on the front panel which blinks various codes.

GCM 2010 has LCD display which displays many of the Status messages. However, there are a few relating to communications that aren't clear.

When there is a communication error it will be displayed but once it has recovered the display will show what the error was by displaying:

^E4 – Low level CAN bus error where the CCM did not acknowledge receiving a message from the Gas Control.

^E5 – Low level CAN bus error where the bus is off.

^E6 – CAN bus communication (the fiber-optic) has timed out.

**Group 4 codes relate to the Liquid Cooling System**

Cooling system description. System includes a reservoir, a pump, one or more heat exchangers, flow switch, level switch and flow sensor on some models. Also included are a filter and various fittings and hoses. New coolant is installed into the reservoir or "tank" from an opening in the unit's front panel where there is a visual level indicator. Coolant flows to the pump inlet from the bottom of the tank, is pumped through a pressure relief or "bypass" valve which limits MAX pressure to 150 PSI bypassing excess flow back into the reservoir. The coolant temperature sensor, TS1, a linear NTC sensor, is mounted on the bypass valve.

From the bypass valve, in most systems, coolant is plumbed to the rear panel coolant supply fitting where it goes to the torch via the RAS 1000 XT, the remote arc starter.

Exceptions are the Ultra-Cut 400 XT which has an additional external heat exchanger and the Auto-Cut 200 XT which has an internal arc starter.

For the Ultra-Cut 400 XT the HE 400 XT external heat exchanger is placed between the plasma power supply and the RAS 1000 XT with the supply coolant passing through the radiator for extra cooling.

In the Auto-Cut 200 XT coolant goes to the water cooled HF (high frequency) coil and then to the torch supply lead attached to the internal torch connection bulkhead.

For the coolant return in most systems the return from the Torch goes to the RAS 1000 XT and on to the return fitting on the rear of the power supply. In the Ultra-Cut 400 XT the return from the RAS1000XT first passes through the HE 400 XT then to the rear panel of the power supply. For the Auto-Cut 200 XT the coolant returns from the torch to the torch bulkhead inside the unit.

Coolant returning from the torch is routed through the rear panel filter then through the radiator (internal heat exchanger) and through the flow switch. Ultra-Cut models also have a flow sensor in series with the flow switch that can detect bubbles in the coolant. Upon leaving the radiator, coolant goes into the bottom inverter "cold plate" or liquid cooled heat sink. It flows through the inverters in series and returns to the tank.

**401 Coolant Level Low**

The coolant reservoir (tank) has a normally open (tank dry) float type level switch, LS1. When the coolant level in the tank is below about ½ full this fault will signal the need to add coolant. It will not stop the process during a cut but will instead show the 405 fault as a warning. As soon as the cut stops it will not allow another to start until the issue is corrected.

Possible causes:

- Coolant is low
- Level switch defective, disconnected or installed upside down.
- Relay board defective or J7 disconnected.
- CCM defective.

Troubleshooting:

1. Confirm visually that the level switch float is below the coolant, if not add more coolant to the tank.
2. Check J7 on the Relay board.
  - a. If properly connected remove J7 and check continuity between pins 2 and 4 (pins 2 & 3 of J71 on the switch itself).
  - b. If no continuity at J71 on the switch, if it is still open, replace the switch.
3. If there was continuity at J7 plug it back in and measure voltage on pin 9 of the 40 pin ribbon cable (Relay board J4 to CCM J23). Common is TP1 on either the Relay or the I/O board.
  - a. Pin 9 should be high, about +10 to +15V. If it's not the relay board is bad or the ribbon cable is shorted.
  - b. To test the ribbon cable remove both ends, J4 on the Relay board and J23 on the I/O board and measure from pin 9 of the ribbon cable to both pin 8 and pin 10 of the cable. Both should be open. If not replace the ribbon cable. Otherwise it's the Relay board.
4. If pin 9 of the 40 pin ribbon cable was high in step 3.a the CCM is defective.

#### 402 Low coolant Flow

The flow switch FS1 is positioned in series with the radiator where it measures the flow returning from the torch. The flow switch serves two purposes, one to insure there is adequate flow for cooling needs and two, it insures the torch consumables are in place so the negative output of the power supply is not exposed. This function is called "Parts in Place" or PIP. The output cannot be enabled if parts are not in place. The normally open flow switch requires 0.7 GPM (2.65 liter/min.) +/- about 10% to close.

When the system is turned on and enabled and fails to achieve proper coolant flow after 4 minutes code 404 will be set. Getting code 402 means it initially had enough flow but something has caused the flow to be reduced. Listed here are things that might happen during cutting to cause reduced flow. For other causes like component failures refer to code 404.

Possible causes for low flow:

- Coolant filter clogged.
- Flow bypass valve incorrect adjustment or defective. Call the factory for instructions.
- Defective pump.
- Coolant supply or return hose twisted or pinched reducing flow.

If coolant flow is not low but code is being set, possible causes:

- Flow switch disconnected or defective.
- Relay PCB.
- CCM.

Troubleshooting:

1. First note whether the fault is an "E" meaning it's currently low or an "L" meaning it was low but isn't now. Flow that remains low could indicate a failed component or a blockage such as clogged filter or pinched hose. It also means you should be able to measure the flow to determine if it is really low or the sensor has a problem.

2. First recycle power. If flow is still low or a component is defective the code should change to 404. Go to that section for further troubleshooting.
3. If after recycling power there is no code, continue cutting to see if it occurs again. Take note of when it occurs, for example if it's with the torch at one end of the table, perhaps the leads get pinched there? In any case go to code 404 section for more information.

## 403 Coolant overheated.

TS1 is a linear negative temperature coefficient (NTC) resistor sensor attached to the brass fitting at the exit of the bypass valve. Here we determine the coolant being supplied to the torch is below the required temperature which is currently 75 deg C (167F). The radiator is on the lower right side of the unit. The fan(s) are behind it and blow out through the radiator. 100A & 200A units may either have 2 smaller fans or one larger one. The 300 & 400A units have one larger one.

Fans operate during cutting and for 4 minutes after last cut then shut off. Exception is AC 200 XT where the fans are on whenever power is on. The external heat exchanger, HE400, fan is thermostatically controlled so it only comes on when coolant is over 60 deg C. It will shut off when the other fans shut off.

Possible reasons for coolant overheated:

Coolant fan(s) failed or defective fan control relay MC2.

- Radiator fins clogged with dirt.
- Duty cycle exceeded (ambient temperature above 40 deg C and operating at high duty cycle).
- Operating with an object placed in close proximity to the air outlet (right side of the unit) or the front panel inlet openings.
- Operating for extended time with right lower side panel removed.
- Defective Relay board.
- Defective CCM.

Troubleshooting:

1. Check for air blowing out of the unit. Remember, except for the AC 200 XT, the fans only run when CNC START is applied and for 4 minutes after cutting, you may have to apply start again to restart the 4 minute time. Fans may be forced on by jumping TP2 on the CCM I/O board to TP1 (ground).
  - a. If using the external HE400XT heat exchanger, optional for 300A, standard for 400A, check for air blowing out of it. Note that the HE400XT fan, controlled by a thermal switch in the HE400XT, only runs if the coolant is over 60 deg C and the internal fans are operating. With the 100 & 200A if it has 2 fans make sure both fans are operating by checking for air both top and bottom of the opening. The fans are difficult to see, perhaps you can use an inspection mirror. Be careful not to get the mirror or your hands into the blades.
2. Fans are powered by 230 VAC. The 230 VAC for the fan(s) is switched by the MC2 control relay (except the AC 200 XT where the fan(s) is powered directly from the T1 transformer at J13).

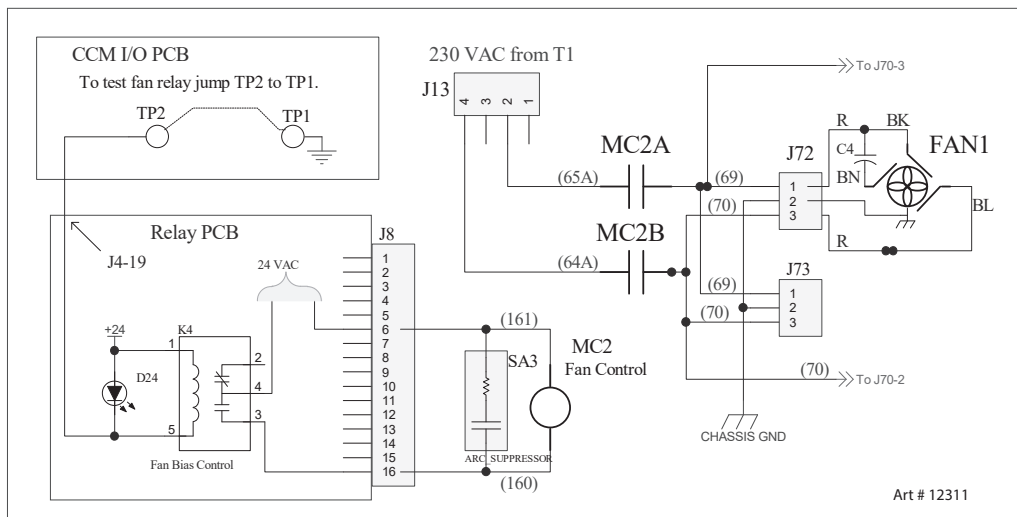

3. Check for 230 VAC at either of the fan connectors, J72 & J73. It may also be measured at the rear panel connector J70 for the HE400XT fan.
  - a. If the fans are not getting 230 VAC, measure for 24 VAC on the coil of MC2. If present and the relay contacts aren't closed the relay is defective. Note, the coil is rectified so you won't measure continuity of even a good coil.
  - b. If 24 VAC is not on the MC2 coil check for D24 on the relay board being ON. If it's on, the Relay board should be providing the 24 VAC so if it's not the Relay board must be defective.
  - c. If D24 is not on, measure on the CCM I/O board between TP2 and the common at TP1. It should be low, near zero volts. If not the CCM is probably defective. Jumper TP2 (I/O board) to TP1. If the fans now come on replace the CCM.
  - d. If jumping TP2 to TP1 does not turn the fans on then the Relay board or the 40 pin ribbon cable pin 19 is at fault.

#### 404 Coolant System Not Ready

When power is applied to the system with External Plasma Enable satisfied and Plasma Power Supply Enabled (switch on 2010 or TSC 3000), assuming there is enough coolant in the tank, after some initial tests taking about 15-20 seconds (see manual section 4 for details of the Start-Up Sequence) the pump will start. Coolant will be pumped through the system. Flow is measured by the FS1 flow switch placed in the torch coolant return path just before the radiator (see plumbing diagram). If the flow doesn't reach at least 0.75 GPM (2.8 lpm) within 4 minutes it will set the 404 fault. The reason for the 4 minutes is a new dry system especially one with long torch leads will take some time before the leads, hoses, radiator and cold plates are full of coolant. More coolant may have to be added. On a system that has been run before it normally takes only a few seconds to establish proper flow. In any case the pump will run for 4 minutes before setting the 404 fault.

First determine if the pump motor is running and if so is there any coolant flowing. With the right lower side panel removed touch the pump and feel for vibration to indicate if the motor is running. Observe the clear coolant hoses to see if they are full of coolant. There are two hose fittings on the back of the tank. The upper one is the coolant return. Remove the tank filler cover. You should see a fairly strong stream of coolant from that fitting. The lower fitting is from the pump bypass valve. If the pump is operating some coolant may be exiting that fitting as well. If these fittings are below the coolant level you may have to drain out some of the coolant to see this. If a strong stream is exiting the bypass (lower) fitting but nothing from the upper fitting, you probably have some kind of blockage.

Reasons for 404 faults (Coolant not flowing):

- In new installation, coolant has not circulated all the way through the leads. Add more coolant if necessary and recycle the power to restart the pump and 4 minute timer.
- Coolant supply & return leads are reversed, check valve in torch coolant return prevents reverse flow.
- Torch parts removed or are wrong style so torch check valve shuts off flow.
- Torch coolant tube damaged or the tube extension (if required) missing.
- No power to pump motor.
- Pump/motor failure.
- Bypass valve defective or adjusted incorrectly.

#### No Power to the Pump Motor

The pump motor is powered by 230 VAC controlled by the MC3 control relay. During the 4 minutes after turning on power, before the 404 fault code is displayed, measure for 230 VAC at the motor connector J16 pin 1 to pin 3.

- a. If the pump motor is not getting 230 VAC, measure for 24 VAC on the coil of MC3. If present and the relay contacts aren't closed the relay is defective. Note, the coil is rectified so you won't measure continuity of even a good coil.
- b. If 24 VAC is not on the MC3 coil check for D27 on the relay board being ON. If it's on the Relay board should be providing the 24 VAC so if it's not the Relay board may be defective. Measure for 24 VAC at J9-6 to J9-12 on the Relay board. If 24 VAC is present and D27 is on, the Relay board or the wire harness is defective.
- c. If D27 is not on, measure on the CCM I/O board between TP3 and the common at TP1. It should be low, near zero volts. If not the CCM is probably defective. Jumper TP3 (I/O board) to TP1. If the pump comes on now replace the CCM.

d. If jumping TP3 to TP1 does not turn the fans on then the Relay board or the 40 pin ribbon cable pin 13 is at fault.

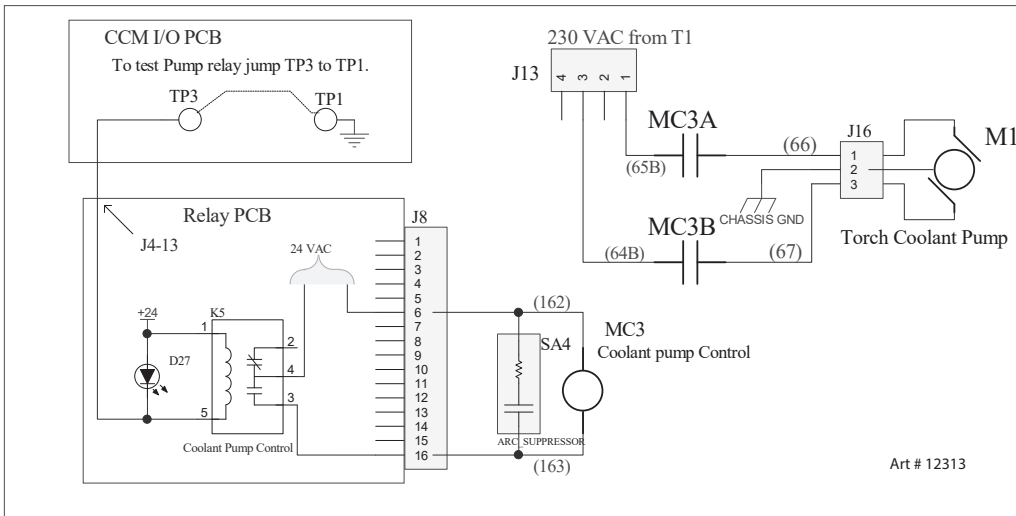

Coolant flows but flow is less than the required minimum:

Test and adjust the pump/bypass valve:

This test measures the “dead head” or blocked flow pressure at the rear panel coolant supply fitting. Perform this test only after the coolant system is fully primed, that is after the coolant is circulated throughout the system and is mostly free of bubbles. It requires a pressure gauge with #6 JIC fitting.

The gauge needs to be able to read at least 173 PSI. Remove the coolant supply hose and connect the pressure gauge in its place. For the Auto-Cut 200 XT connect the gauge in place of the torch coolant supply hose on the torch connection bulkhead. This is a #5 JIC fitting.



**NOTE!**  
Do not put the gauge in-line and attempt to pinch off the hose to block the flow. It is very difficult to totally block the flow and failure to do so will result in incorrect setting of the bypass.

Turn the on the unit. You will have 4 minutes to perform the test/adjustment before the system times out with a coolant flow fault. If that happens recycling the power gives you another 4 minutes.

1. The pressure on the gauge should be close to 173 (170-175) PSI. If it is the pump and the bypass are OK.
2. If the pressure is less than 173 PSI adjust the bypass screw clockwise to raise the pressure. If you can change the pressure with the bypass screw but cannot reach 173 PSI it is likely the pump is worn out or damaged. If the pressure does not change using the bypass screw it is likely the bypass is defective.
3. If the pressure is above 173 reduce the pressure by adjusting the bypass valve screw counter clockwise.

**Coolant flow test:**

In addition to the pressure test or in place of it if you don't have a gauge, determine if the flow returning from the torch (the flow that passes through the FS1), is greater than the required minimum. With the unit switched off remove the return hose from the back of the power supply. Place it in a container of a known volume. Turn the unit on and let the pump run exactly 30 seconds. It should pump at least 3/8 gal. (1.4 l). Use a larger container in case the flow is greater and it overflows.

If the flow is lower than 0.75 GPM:

- Look for restrictions such as sharp bends or something pinching the coolant hoses or torch leads.
- Other possibilities are the bypass valve has been adjusted wrong (someone may have turned the adjustment screw) see pressure test/adjustment above
- The pump is worn out (may be the case with an older unit).

Coolant flow is correct but system doesn't detect it due to defective components:

- Defective or disconnected FS1 flow switch.
- Relay board.
- CCM.

Flow Switch FS1 disconnected – FS1 comes with wire about 1 ft. long and a connector that connects to a 3 wire harness. This could be disconnected at either end, J74 or J5 on the relay board.

Defective FS1 – The flow switch, normally open, closes when flow through it exceeds 0.75 GPM, could be open. Easiest place to measure the switch is at the J5 harness connector that plugs into the Pilot board. Assuming you have previously determined flow is sufficient, disconnect J5 from the Pilot board, start the unit so the coolant is flowing and measure continuity between the 2 pins of J5.

- If there is no continuity either the switch is open or the harness between J5 and J74 at FS1 is open.
- If there is continuity between the J5 pins with sufficient coolant flow then either relay board or the CCM is faulty.
- Relay board
- CCM

#### **405 Low Coolant Level Warning**

If the coolant level becomes low while cutting it is not necessary to immediately stop the cut as there is still enough coolant to continue so we display E405 as a warning. Once the cut stops if the coolant is still low the display changes to E401 and prevents starting another cut. Refer to the section for code 401 for troubleshooting.

#### **406 Coolant Flow Low Warning**

Ultra-Cut XT units, in addition to a coolant flow switch, include a turbine flow sensor FL1, referred to in the plumbing diagram as a "bubble sensor", with a pulse output that accurately measures coolant flow and in addition can detect the presence of gas bubbles in the coolant. Gas bubbles from leaking seals in the torch or hose fittings have been proven to reduce consumable life. This code is a warning, it does not prevent cutting but if it persists the cause should be investigated.

#### **407 Coolant Overheated due to High Ambient**

As described in the section for codes 259-264 the CCM measures the ambient temperature using sensor TS2 and, like with the inverters, if the coolant is over temperature we first check the ambient and if it is above 40 deg C we attribute the cause of the coolant over temperature to high ambient and of course the solution is to lower the ambient or reduce the duty cycle.

The other possibility is the ambient measuring circuit is defective and the coolant is overheated. In that case you would have to go to the section for code 403 to find the cause of the coolant overheating and go to section for codes 259-264 to determine what is wrong with the TS2 circuit.

### **The 5 Group relates to CANBUS (Fiber optic) communication errors**

#### **501 CANBUS Failure to Acknowledge fault.**

The CCM communicates with the gas controls (except GCM 1000 XT) over a fiber-optic cable using the CANBUS protocol. The CCM is looking for a signal from the gas control (GCM 2010 or DMC) over the fiber-optic link. No signal has been detected. Communication with the DPC which is relayed through the DMC sets a different code, 301, if there is a problem with it.

## Possible causes:

- Gas control is GCM 1000 XT (Auto-Cut 300XT) which has no fiber-optic, with Basic ID problem.
- CANBUS / Fiber-optic problem to either the GCM 2010 or the DMC (part of DFC 3000).
- Control Cable to DMC or GCM 2010 defective.
- Gas control (DMC or GCM 2010) main PCB blown fuse or defective.
- DMC power supply PCB blown fuse or defective.
- CCM defective.

## Troubleshooting:

1. GCM 1000XT (also called a Basic Gas Control) does not use CANBUS (fiber-optic) communication. A jumper in the gas control connector J56 pins 8 & 9, gives the signal "Basic ID" telling the CCM not to expect any CANBUS. If somewhere this circuit is open, in the Gas Control cable, connector pins, connection from the rear panel GCM connector, J55, to the CCM (J26) CCM will expect to see a CANBUS connection and report this error because there is no CANBUS connected.
2. DFC 3000. If the gas control does not have power it will not communicate. Check for power to the gas control boards.
  - a. When using Auto Gas (DFC3000) with DMC & DPC if there is no power to the DMC main board, the green power light on the DMC front panel will not be lighted. The main board receives several voltages from its separate power supply board. For communication it needs +5VDC. There is a green LED, D17 (first on the left of the row of LEDs.) that lights when the main board has +5V power.
  - b. The DMC power supply board has several blue LEDs that light when it has power. If none of these are on check for the control cable being connected or the circuit breaker, CB2, on the plasma supply rear panel may be tripped in which case there is probably a short somewhere.
  - c. The DMC power supply which supplies several voltages could be missing one or more and still have some blue LEDs lighted. Check for voltages.
3. GCM 2010.
4. CANBUS / Fiber-optic communication errors can be difficult to troubleshoot, especially when they are intermittent. See "Test the Fiber" below. Things to look for are:
  - a. The connectors not locked in place at either end of the fiber.
  - b. The fiber is damaged or bent sharply. This should not be the case if the fiber is inside the protective hose and the hose properly secured in the strain relief but that is not always the case.
  - c. Dirt on the ends of the fiber or in the receiver/transmitter where the fiber plugs in. Blow out gently with clean dry air such as is used to clean a camera lens.
  - d. Excessive electrical interference. While the fiber is immune to EMI it can bother circuits at either end. Check that all the grounding connections are connected per the manual and are clean and tight. Check the resistance of the ground rod (with all wires disconnected from it). It may have increased due to dryer weather conditions. See the instructions in the Plasma Installation manual.
  - e. Defective receiver/transmitter or other circuits on either CCM or Gas Control main board. Otherwise replace either (or both) Gas Control main board or CCM.

Transmitter / Receiver Tests. The transmitter/receiver pair on the PCB and the fiber cable looks like this:



Art # 12314

Test the fiber:

Note that the fiber goes from black on one end to blue on the other. Shine a bright light into one end and you should be able to see light from the other end. This tells you the light is getting through but doesn't prove it is strong enough.

The CCM is the communication master. It transmits then expects a reply from the Gas Control Module (GCM). The GCM does not transmit on its own, only in response to a request from the CCM.

The black end of the fiber cable is inserted into the transmitter which is the gray housing on the PCB. The other end of the transmitting fiber is blue and goes into the receiver with the black housing.

A few seconds after power is turned on and when the pump has started up the CCM will try to transmit continuously for a while. You can unplug the fiber from the CCM and should see the transmitter red LED on the CCM PCB blinking. It may stop after a while so recycle power before deciding it isn't working. If no light, check one of the other transmitter/receiver pairs. If none of them blink the problem is in the CCM.

If at least one transmitter blinks plug the fiber back into that one then at the Gas Control end of the fiber (unplugged) you should see the red light coming out of the blue end.

The Gas Control transmitter does not transmit except in response to a request from the CCM so you will not see any light from the GCM transmitter with the cable unplugged. However, if you turn the connector 90 deg and insert the blue end into the receiver (black housing), leaving transmitter open, then the GCM should receive the requests from the CCM and should blink it's transmitter (gray housing) in response. If not, problem is likely on the GCM board assuming it has power.

It is still possible even though you see the red light coming out the GCM end of the fiber that dirt in the transmitter or receiver or on the fiber ends or the fiber is damaged so the light even though visible is not strong enough for the GCM board. If all else fails replace the fiber cable and both CCM and GCM PCB.

#### **502 CANBUS off due to excessive errors.**

See 501 code for troubleshooting CANBUS faults.

#### **503 CANBUS Data Error Warning.**

This is a warning, does not shut the system down but is an indication that it probably will shut down soon (502 code). Troubleshooting is same as for 501.

#### **504 Reserved for future use.**

Should not get this but if it happens may be due to EMI. Contact customer service.

**Group 6 codes relate to the CCM and program updates. One exception is 619 which is a coolant flow switch FS1 fault.**

#### **601-611 Various CCM CPU board internal faults.**

For most of these faults try recycling the power but if the problem returns only thing to do is replace the CCM. Exceptions are:

1. 603 This is one of the reserved codes from the earlier product. Not used so it should never appear, if it does contact customer service.
2. 607 Processor over temperature could occur if the ambient in the area of the CCM is too high. Try opening the upper right side panel, perhaps blow some air to cool it off. If that doesn't help or the ambient was not too hot to begin with, replace the CCM.
3. 611 Code has various causes most of which require replacing the CCM. However, one possible cause is the programming jumper on the CPU board (under the Static suppression PCB) has been left in the PROG position. This is a factory setting used during initial programming and should never be found in the field. It is NOT used for application code updates However, if someone did move it 611 will be the result.

**612 USB port power fault.**

USB port supplies +5V to power some USB devices such as the flash drive (thumb drive, memory stick), used for program updates. A flash drive is the only device currently being used with this USB port. This fault detected no or low voltage to the port. This could be a shorted flash drive or some other device that draws too much current exceeding the limits of the USB power supply.

Try another flash drive or if you know this one is OK (it works with a computer), then replace the CCM.

**613 USB Log File Creation Fault**

When updating the CCM, DMC and DPC programs from a flash drive, a log file called CCM\_LOG.TXT is created on the flash which reports on the results of the update including any problems. If that log file can't be created you get 613. This may be a problem with the flash drive having too many other files on it or a problem with its format that may not be compatible with the CCM.

1. Try putting the update files on a different, preferably empty, flash drive.
2. Or save all the flash drive files in another place on your computer, then delete all the files on the flash drive. Now copy onto the flash drive only the files required for program updates.
3. If the above doesn't work, making sure you still have copies of the files, format your flash drive which erases everything on it. Now load only the files required for program update.

**614 No USF File**

The file VTCCMFV.USF is required on the flash drive along with the program files when performing a program update. If it's either missing or corrupted the display will show b614. The "b" indicates the fault is generated by the Bootloader program rather than the normal application program code. Note that each new revision of the program files is supplied with a new VTCCMFV.USF. Even though the name is the same it requires the new version of this file that is supplied with the application code.

1. Install the correct VTCCMFV.USF on the flash drive.
2. If you already have the correct version of VTCCMFV.USF perhaps the flash drive is the problem. Follow the instructions for code 613.

**615-617 No Update File for CCM, DPC or DMC found**

Program files for the CCM, DMC & DPC may be updated through the plasma supply's USB port. The GCM2010 is updated by other means. For a unit with GCM 2010 the CCM may still be updated using the USB. Program update files are in the format Cx\_x\_0.S (CCM); Mx\_x\_0.S (DMC) and Px\_x\_0.S (DPC).

If the Bootloader finds there are 3 devices, CCM, DMC & DPC on the CANBUS but the flash drive doesn't have all 3 update files it will go ahead and update those it has but will show a code indicating that one or more are missing (615 for CCM; 616 for DMC; 617 for DPC).

Try another flash drive or if you know this one is OK (it works with a computer), then replace the CCM.

**This completes the Advanced Troubleshooting information.**

# STATEMENT OF WARRANTY

---

**LIMITED WARRANTY:** Thermal Dynamics Corporation (here in after "Thermal") warrants that its products will be free of defects in workmanship or material. Should any failure to conform to this warranty appear within the time period applicable to the Thermal products as stated below, Thermal shall, upon notification thereof and substantiation that the product has been stored, installed, operated, and maintained in accordance with Thermal's specifications, instructions, recommendations and recognized standard industry practice, and not subject to misuse, repair, neglect, alteration, or accident, correct such defects by suitable repair or replacement, at Thermal's sole option, of any components or parts of the product determined by Thermal to be defective.

**THIS WARRANTY IS EXCLUSIVE AND IS IN LIEU OF ANY WARRANTY OF MERCHANTABILITY OR FITNESS FOR A PARTICULAR PURPOSE.**

**LIMITATION OF LIABILITY:** Thermal shall not under any circumstances be liable for special or consequential damages, such as, but not limited to, damage or loss of purchased or replacement goods, or claims of customers of distributor (hereinafter "Purchaser") for service interruption. The remedies of the Purchaser set forth herein are exclusive and the liability of Thermal with respect to any contract, or anything done in connection therewith such as the performance or breach thereof, or from the manufacture, sale, delivery, resale, or use of any goods covered by or furnished by Thermal whether arising out of contract, negligence, strict tort, or under any warranty, or otherwise, shall not, except as expressly provided herein, exceed the price of the goods upon which such liability is based.

**THIS WARRANTY BECOMES INVALID IF REPLACEMENT PARTS OR ACCESSORIES ARE USED WHICH MAY IMPAIR THE SAFETY OR PERFORMANCE OF ANY THERMAL PRODUCT.**

**THIS WARRANTY IS INVALID IF THE PRODUCT IS SOLD BY NON-AUTHORIZED PERSONS.**

The limited warranty periods for this product shall be: A maximum of three (3) years from date of sale to an authorized distributor and a maximum of two (2) years from date of sale by such distributor to the Purchaser, and with further limitations on such two (2) year period (see chart below).

	<b>Parts</b>	<b>Labor</b>
PAK 300i Power Supplies and Components	2 Years	1 Year
<b><u>Torch And Leads</u></b>		
PT-26P Torch (Excluding Consumable Parts)	1 Year	1 Year
<b><u>Repair/Replacement Parts</u></b>		
	90 Days	90 Days

Warranty repairs or replacement claims under this limited warranty must be submitted by an authorized Thermal Dynamics® repair facility within thirty (30) days of the repair. No transportation costs of any kind will be paid under this warranty. Transportation charges to send products to an authorized warranty repair facility shall be the responsibility of the customer. All returned goods shall be at the customer's risk and expense. This warranty supersedes all previous Thermal warranties.

**Effective July 31, 2024**



Thermal Dynamics / [thermal-dynamics.com](http://thermal-dynamics.com)

